

PEDIMAT AA WITH ALUMINUM TAPERED ANGLE FRAME

INSERT STYLE: INSERT COLOR: PLEASE ADVISE CATALOG NUMBER: M2 PART NUMBER:

NO.	REVISION	DATE	BY
NO.	F&F RELEASE	DATE	BY

- | | | | | | | |
|---|---|---|---|--|---|---|
|  |  |  |  |  |  |  |
| RECYCLED RUBBER | EXTERIOR CARPET | HEAVY-DUTY CARPET | VINYL | VINYL-ABRASIVE | SERRATED ALUM. INSERT | POURED ABRASIVE INSERT |
| M2RR
19R001XXX | M2EC
19C018XXX | M2HC
19C010XXX | M2V
19V002XXX | M2VA
19M001XXX | M2SAI
19A001001 | M2PA
19A005XXX |

PEDIMAT AA INSERT STYLES

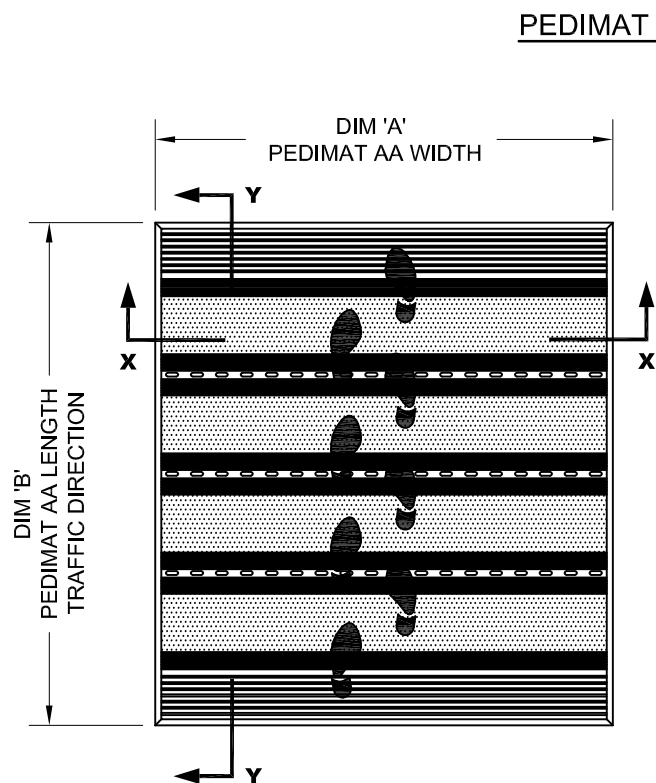

TYPICAL PLAN VIEW

SQUARE END VINYL
1" (25.4mm) WIDE (17V013XXX)
2" (50.8mm) WIDE (17V014XXX)

ALUMINUM TAPERED ANGLE FRAME (16A051XXX)

FEMALE PEDIMAT AA RAIL (17A002XXX)

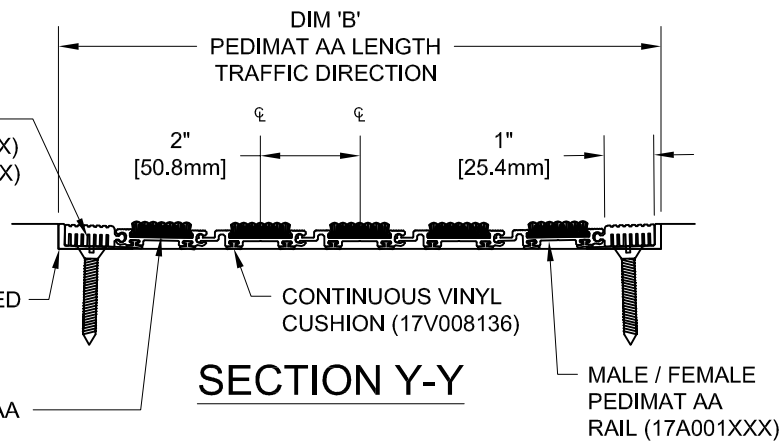

SECTION Y-Y

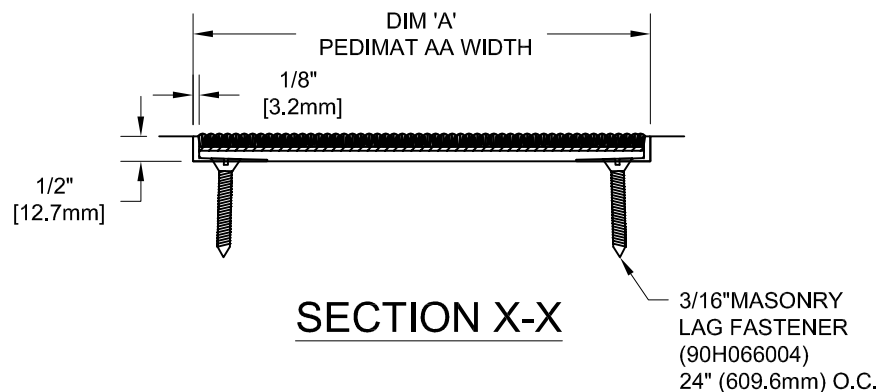

SECTION X-X

NOTES:

*ALL SURFACES IN CONTACT WITH MASONRY ARE TO RECEIVE A COAT OF ZINC CHROMATE PRIMER

*MAX. SINGLE GRID SIZE NOT TO EXCEED 12'-0" (3.66M) IN WIDTH (DIM "A") OR 100 SQUARE FEET

*PLEASE VERIFY TRAFFIC DIRECTION

*PEDIMAT AA SHALL BE ABLE TO SUPPORT A 350 LB. ROLLING LOAD. LARGER LOADING MAY BE ACCOMODATED. CONTACT C/S SALES WITH SPECIFIC LOADING REQUIREMENTS.

*ADDITIONAL SPECIFICATIONS ARE CONTAINED IN THE LATEST C/S CATALOG OR AT C-SGROUP.COM AND ARE CONSIDERED PART OF THIS TRANSMITTAL.



PLEASE VERIFY ALL	QTY	MARK #	LOCATION	MODEL	DIM 'A' WIDTH	DIM 'B' LENGTH	FINISH	NOTES

PROJECT:		
LOCATION:		
CONTRACTOR:		
AGENT:		SHT:
DRG. BY:	DATE:	JOB NO.: