

PEDIMAT WITH ALUMINUM TAPERED ANGLE FRAME

INSERT STYLE: INSERT COLOR: PLEASE ADVISE CATALOG NUMBER: M1 PART NUMBER:

| | | | |
|-----|-------------|------|----|
| NO. | REVISION | DATE | BY |
| NO. | F&F RELEASE | DATE | BY |
| | | | |
| | | | |

- 
EXTERIOR CARPET
 M1EC
 19C018XXX
- 
HEAVY-DUTY CARPET
 M1HC
 19C010XXX
- 
RUBBER
 M1V
 19V022501
 #8501 BLACK

PEDIMAT INSERT STYLES

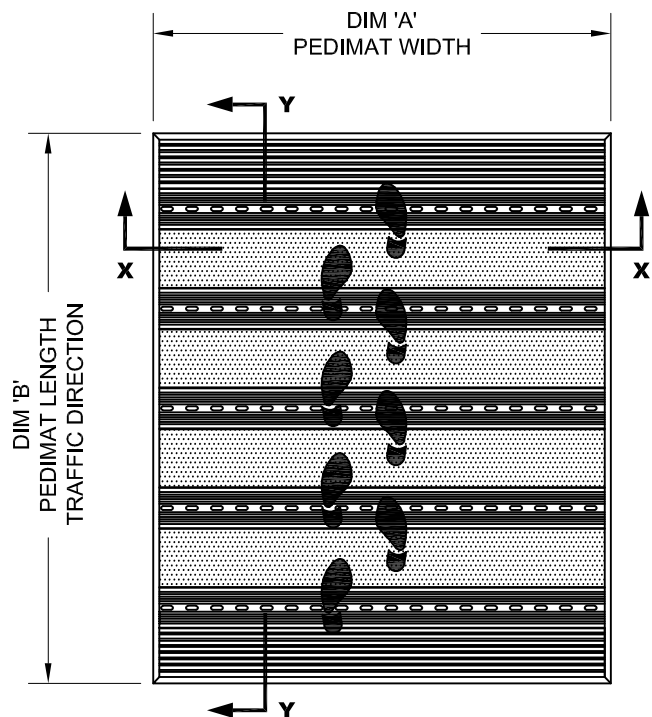

TYPICAL PLAN VIEW

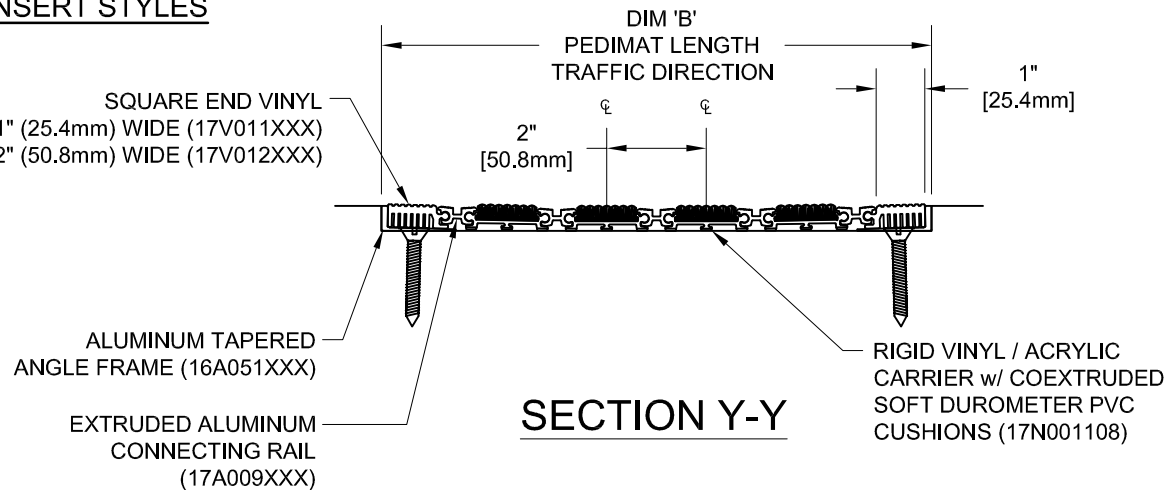

SECTION Y-Y

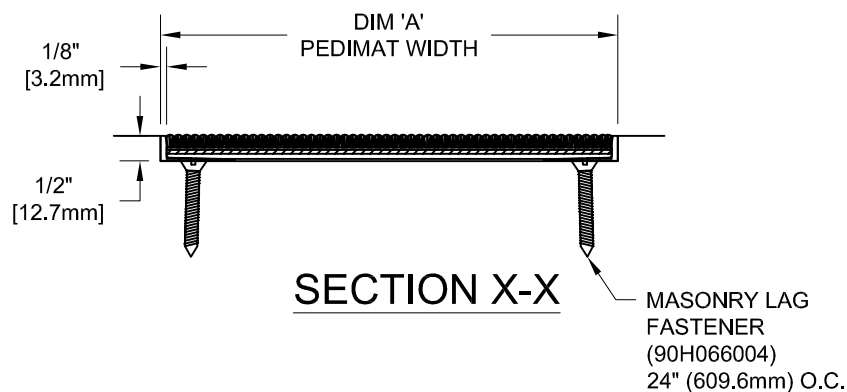

SECTION X-X

NOTES:

*ALL SURFACES IN CONTACT WITH MASONRY ARE TO RECEIVE A COAT OF ZINC CHROMATE PRIMER

*MAX. SINGLE GRID SIZE NOT TO EXCEED 12'-0" (3.66M) IN WIDTH (DIM "A") OR 100 SQUARE FEET

*PLEASE VERIFY TRAFFIC DIRECTION

*ADDITIONAL SPECIFICATIONS ARE CONTAINED IN THE LATEST C/S CATALOG OR AT C-SGROUP.COM AND ARE CONSIDERED PART OF THIS TRANSMITTAL.

*PEDIMAT SHALL BE ABLE TO SUPPORT A 350 LB. ROLLING LOAD. LARGER LOADING MAY BE ACCOMMODATED. CONTACT C/S SALES WITH SPECIFIC LOADING REQUIREMENTS.



| PLEASE VERIFY ALL | QTY | MARK # | LOCATION | MODEL | DIM 'A' WIDTH | DIM 'B' LENGTH | FINISH | NOTES |
|-------------------|-----|--------|----------|-------|---------------|----------------|--------|-------|
| | | | | | | | | |
| | | | | | | | | |
| | | | | | | | | |
| | | | | | | | | |

| | | |
|-------------|-------|----------|
| PROJECT: | | |
| LOCATION: | | |
| CONTRACTOR: | | |
| AGENT: | | SHT: |
| DRG. BY: | DATE: | JOB NO.: |