

PEDIGRID WITH DRAIN PAN

INSERT STYLE:

INSERT COLOR:

CATALOG NUMBER: G1

PART NUMBER:

NO.	REVISION	DATE	BY
NO.	F&F RELEASE	DATE	BY

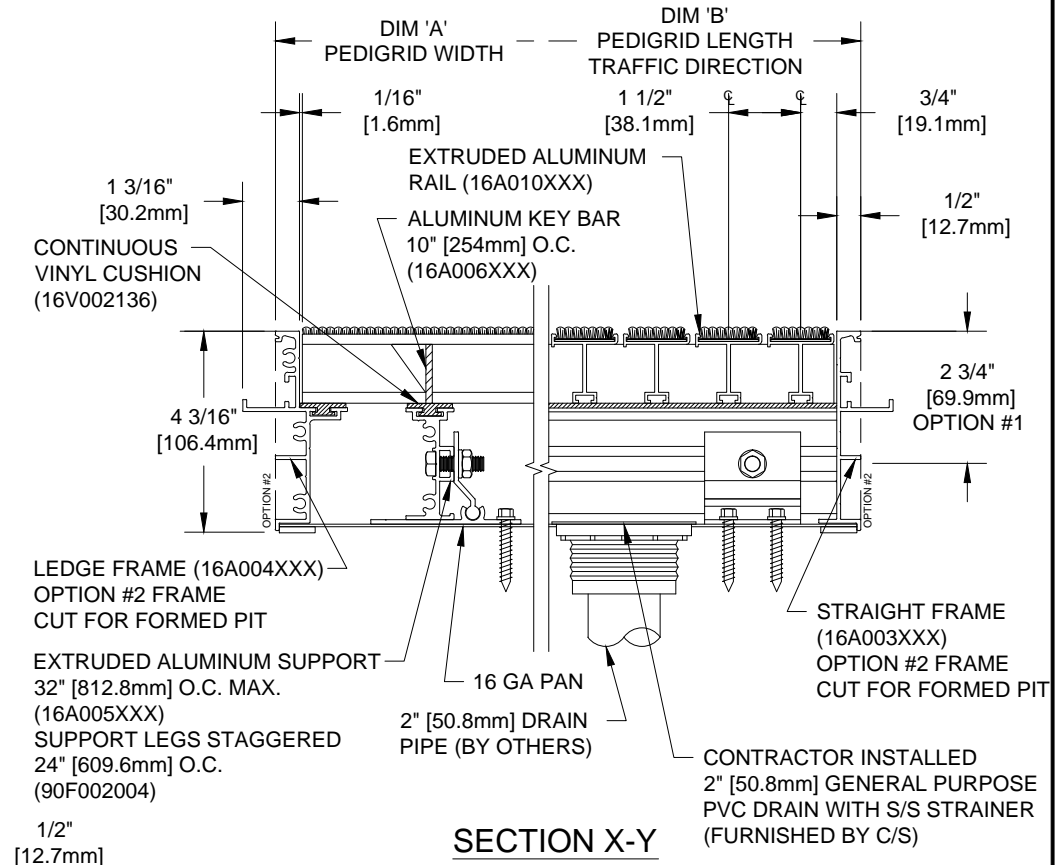
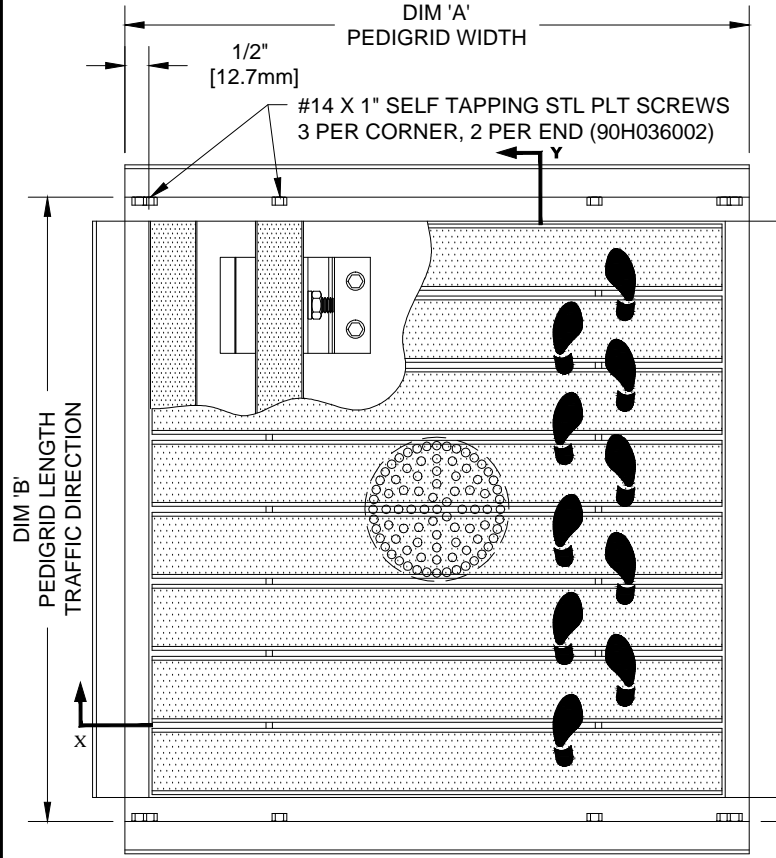

NOTES:

- *GRIDS OVER STRUCTURES @ 32" O.C. TO SUPPORT A MAX LOAD OF 300 LB PER SQ. FT. ALL GRIDS WITH LEVEL BASE FRAME TO SUPPORT A 400 LB. ROLLING LOAD. LARGER LOADING MAY BE ACCOMMODATED. CONTACT C/S SALES WITH SPECIFIC LOADING REQUIREMENTS.
- *PLEASE VERIFY TRAFFIC DIRECTION.
- *MAXIMUM MODULE SIZE OF GRID NOT TO EXCEED 12'-0" [3.6M] IN WIDTH (DIM "A") & 3'-0" [91M] IN LENGTH T.D. (DIM "B").
- *ALL SURFACES IN CONTACT WITH MASONRY ARE TO RECEIVE A COAT OF ZINC CHROMATE PRIMER.
- *MITERED FRAME CORNERS ARE NOT AVAILABLE.
- *WITH OPTION #2, THE ANCHOR LEG IS CUT OFF TO ALLOW FOR FLUSH MOUNTING IN A FORMED PIT.
- *DUE TO 1 1/2" MODULE OF PEDIGRID, INSIDE OF FRAME DIMENSION SHOULD BE CHANGED ONLY IN INCREMENTS OF 1 1/2" [38.1mm] TO AVOID THE USE OF FILLER BARS.
- *ADDITIONAL SPECIFICATIONS ARE CONTAINED IN THE LATEST C/S CATALOG OR AT C-SGROUP.COM AND ARE CONSIDERED PART OF THIS TRANSMITTAL.



PLEASE VERIFY ALL	QTY	MARK #	LOCATION	MODEL	DIM 'A' WIDTH	DIM 'B' LENGTH	FINISH	REMARKS

PROJECT:		
LOCATION:		
CONTRACTOR:		
AGENT:		SHT:
DRG. BY:	DATE:	JOB NO.: