

Explovent® ERP-T-FS

Fire Suppression Pressure Relief Systems

Application:

In facilities where high-pressure gaseous fire suppressant agents are employed as the method to combat fire.

Function:

Units respond to pressure rise experienced during the release of fire suppressant agents. Panels open relieving the pressure spike and then come to a near closed position to maintain required fire suppression agent concentration.

Two models are available:

- Pressure Trip Switch activated (released) by the suppressant being piped to the trip switch at the same time as being introduced into the room. Once released the pressure pushes the panel open.
- Electromagnetic latch linked with the smoke or fire alarm control system. With a disconnection of power, the panel is pushed open by the pressure rise in the room.

Technical Features and Options:

- Designed to protect interior wall and ceiling structures from the pressure rise experienced during the release of fire suppressant agents into a confined room space.
- Core material to be insulated, metal clad, polycarbonate, or other as required.
- Interior and exterior seals provide a comfortable draft-free environment.
- System can be field tested for release through non-destructive means.
- Can save on damage cost in event of an accident within the facility.
- Architectural design offers non-industrial appearance.

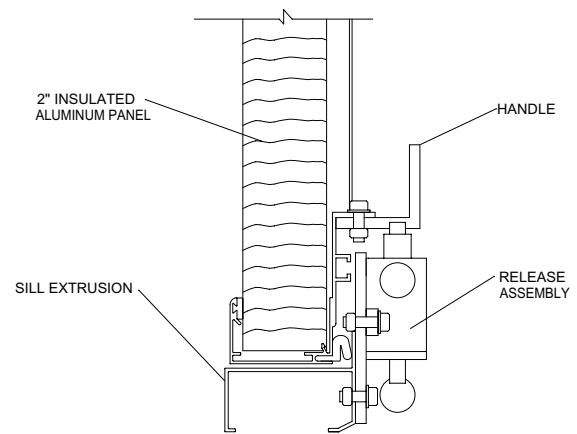
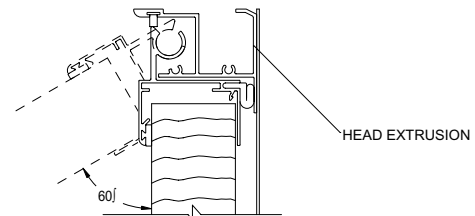

ERP-T-FS

SPEC SECTION 13074

PART 1 GENERAL

1.01 Section Includes

A. Furnished all pressure relief panels, frames, and attachment hardware necessary to complete the work as indicated on the drawing.

1.02 Related Sections

A. Piping and hook up of fire suppression agent to pressure relief panel trip value.

B. Steel Framing

C. Sealant's Section

1.03 References

A. Aluminum Association, Section 1, Specifications for Aluminum Structures.

B. AAMA-603 Voluntary Performance Requirements and Test Procedures for Pigmented Organic Coatings on Aluminum Extrusions.

C. ASTM-D35 Standard Test Method for Rate of Burning and/or Extent and Time of Burning of Self-supporting Plastics in Horizontal Position.

D. ASTM-E-84 Standard Test Method for Surface Burning Characteristics of Building Materials.

E. NFPA 68 Guide for Venting of Deflagrations, 1999 Edition.

F. Factory Mutual Engineering Corporation, 1-44, Damage-Limiting Construction, July 1991.

1.04 System Description

A. Fire suppression pressure relief panel designed to release upon activation of trip value and increase in static pressure differential between interior and exterior of 3 lb/ft².

B. The panels shall be designed to withstand a maximum a maximum wind load of 30 lb/ft².

C. The panel pressure relief system shall allow for manual retrieval and reset.

1.05 Submittals

A. Manufacturer for approval prior to fabrication shall submit complete shop drawings.

B. Installation instruction shall be submitted with the shop drawings.

1.06 Quality Testing

A. The panel system shall be produced by a manufacturer regularly engaged in manufacture of similar products and with a verifiable history of successful product applications.

1.07 Delivery, Storage, & Handling

A. All explosion & pressure relief vents, frames and curbs shall be factory assembled in units and shipped to the job site.

B. Deliver to site in original, unopened containers and/or pallets bearing manufacturer's name and label.

1.08 Limited Warranty

A. All Explovent® products are sold with standard limited warranty, copy of which is available at our main office.

PART 2 PRODUCTS

2.01 Manufacturers

A. Explovent® pressure relief panel systems shall be manufactured by Conspec Systems, Inc., Cranford, NJ; or C/S Construction Specialties Company, Mississauga, Ontario.

B. Installation shall be performed in accordance with approved drawings and installation instructions.

C. Manufacturer to have complete in-house finishing capabilities.

2.04 Materials

A. Panels shall be semi-rigid insulated core with .032" (.81mm) thick 3003 or 5005 stucco (or optional smooth finish) aluminum allot sheet laminated to both sides. Total depth of panel shall be 2" (50.8mm)

B. Minimum panel size to be 18"x18". Larger sizes made to suit openings available.

C. Panel framing components shall be .063" (1.6mm) 6063-T52 alloy extruded aluminum. All fasteners shall be aluminum or stainless steel.

D. Exterior panel gaskets shall be a pile fiber type with a continuous polypropylene center fin. Interior gaskets shall consist of open cell compression foam and clad with a polyethylene liner.

2.03 Fabrication

A. Fabricate the ERP-T-FS pressure relief panels to the sizes shown on the approved shop drawings.

B. Panels shall be top hinged as detailed.

C. All panels, frames, and release mechanisms shall be factory assembled in units and shipped to the job site.

D. Head, sill, jamb, and mullion frame members to be one piece extruded aluminum structural members as detailed, and to have integral caulking slots. Mullions to be two-piece interlocking assemblies, which allow for expansion and contraction, and for individual panel remove-ability.

E. All panels shall have exterior pile gaskets and interior compression (or magnet) gaskets to minimize air leakage and water entertainment when closed.

F. The release mechanism shall be mounted to the panel frame.

G. System options: Trip valve release mechanism may be replaced with a non-residual 24-vdc electromagnet catching device. System controls and wiring by others.

2.04 Factory Finishing

A. Duracron Super 600®: Panels and frames shall be finished with a thermosetting acrylic coating. Total coating to be minimum 0.8 mil (0.02mm) thick.

B. Kynar 500®: Panels and frames shall be finished in full strength, 70% resin Kynar 500® Fluoropolymer Coating consisting of prime coat and color coat minimum 1 mil (0.025mm) thick.

C. Color to be selected from manufacturers standard color selection.

PART 3 EXECUTION

3.01 Installation

A. The vents must be installed in accordance with shop drawings, the installation instructions, and any special instructions on the shop drawing.

B. Schedule 40 pipe with 300 lb. malleable iron fittings. Ports on the trip valve are " NPT female. Piping by others.

C/S GROUP OF COMPANIES

MANUFACTURING/SALES/DISTRIBUTION LOCATIONS

U.S.A. Conspec Systems, Inc., Cranford, NJ Tel:(800)222-0201 Fax:(800)293-4509

Canada C/S Construction Specialties Company, Mississauga, Ont. Tel:(905)274-3611 Fax:(905)274-6241

For Phone Number of Nearest Representative, Call Toll Free (800)222-0201 (U.S.A.) and (888)895-8955 (Canada only).

For Assistance with Overseas Requirements, Fax C/S International (908)236-2903.

©Copyright 2001 Conspec Systems, Inc. Reserves the Right to Make Design Changes or to Withdraw Any Design Without Notice.

Printed in U.S.A.