

Explovent® ERP-PC

*Top or Bottom Hinged, Explosion Vent
Polycarbonate Core Insert*

Application:

Any facility where potentially explosive atmospheres exist and require explosion venting with natural lighting. Facilities handling hazardous materials are required by numerous building codes to provide adequate safeguards against explosions.

Function:

An explosion vent is designed to be the weakest part of the external structure. As the explosion vent experiences the pressure rise, it opens quickly allowing the rapidly expanding heated gases to be released to the outside.

Technical Features and Options:

- ERP-PC meets '98 NFPA 68 Guide for Venting of Deflagrations and major building and fire code requirements.
- Brighten up the workspace while reducing the need for artificial lighting. Specify one of our attractive high strength translucent polycarbonate inserts. They are available in clear, white, and bronze tint.
- System can be field tested for release through non-destructive means.
- Patented panel latch mechanism is factory calibrated to meet critical design release values.
- Explovent® can be calibrated for very low pressure release settings since the system is designed to reset following negative wind actuation.
- Smooth beveled surfaces reduce dust accumulation and allow for ease of cleaning, a key to reducing secondary explosions.
- Our rotating hold-open device protects the structure from implosion forces as super heated gases begin to cool.
- Shock restraint device designed to cushion the panel's deceleration as the full open position is reached.

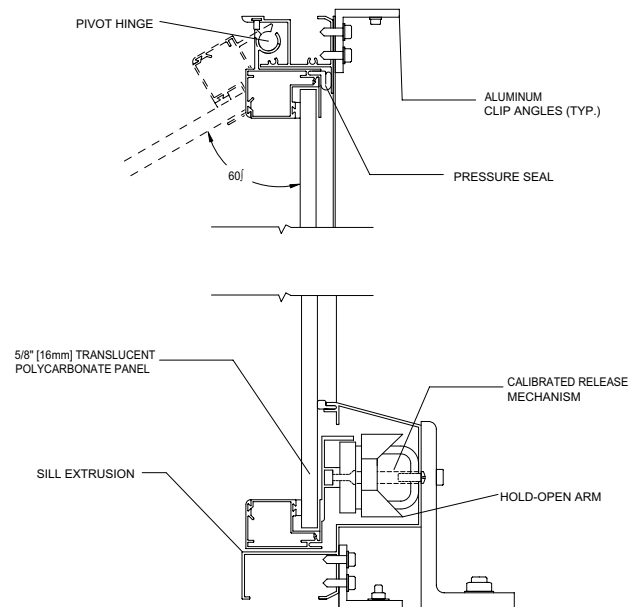

ERP-T-PC

SPEC SECTION 13074

PART 1 GENERAL

A. Furnish all pressure relief panels, frames, and attachment hardware necessary to complete the work as indicated on the drawings, and as described in the specifications.

1.02 Related Sections

- A. Steel Framing Section
- B. Flashing and Sheet metal Section
- C. Sealants Section

1.03 References

- A. Aluminum Association, Section 1, Specifications for Aluminum Structures.
- B. AAMA-603 Voluntary Performance Requirements and Test Procedures for Pigmented Organic Coatings on Aluminum Extrusions.
- C. ASTM-D35 Standard Test Method for Rate of Burning and/or Extent and Time of Burning of Self-supporting Plastics in Horizontal Position.
- D. ASTM-E-84 Standard Test Method for Surface Burning Characteristics of Building Materials.
- E. NFPA 68 Guide for Venting of Deflagrations, 1999 Edition.
- F. Factory Mutual Engineering Corporation, 1-44, Damage-Limiting Construction, July 1991.

1.04 System Description

- A. Pressure relief panel system shall be designed and shop calibrated to release at a static pressure differential between interior and exterior of $__\text{ lb/ft}^2$ ($__\text{ pascals}$) $\pm 10\%$.
- B. The panels and structure supports shall be designed to withstand a maximum wind load of 30 lb/ft² (1436 pascals). Note: Contact Conspec Systems, Inc. (or C/S Construction Specialties Company) if a higher loading requirement is needed.
- C. Each panel shall be equipped with a restraint/hold open mechanism designed to cushion the panel's deceleration as the full open position is reached; and to minimize the development of a vacuum in the enclosure when the heated gases cool.
- D. Panels shall have been tested by Factory Mutual or CANMET (Canada Centre for Mineral and Energy Technology). Dynamic test data shall demonstrate that the panel release, restraint, and hold open mechanisms performed properly, the panels were not structurally damaged, and the panels could be reset. In addition, the test data shall include all pertinent operating conditions under which the test was conducted including static release pressure and the additional pressure rise within the chamber.

- E. System design shall allow for non-destructive testing in the field to verify that the panel's release at the specified static design pressure.
- F. The panel pressure relief system shall allow for manual (or semi-automatic) retrieval after release.
- G. The weight of the fabricated panel shall not exceed 2.5 lb/ft² (12.2 kg/m²).

1.05 Submittals

- A. The manufacturer shall submit complete shop drawings for approval prior in fabrication. Drawings shall show product location, fabrication details, specified static release loads, and static release forces.
- B. Installation instruction instructions shall be submitted with the shop drawings.

1.06 Quality Testing

- A. The panel system shall be produced by a manufacturer regularly engaged in manufacture of similar products and with a verifiable history of successful product applications.
- B. Products equal to this specification in design, performance, and testing shall be considered provided they are submitted for approval at least 10 days prior to bid date. Submittal for approval shall include product literature, details, product samples, and verification of non-destructive field-testing capabilities. Failure to comply with these requirements shall be cause for rejection.

1.07 Limited Warranty

- A. All Explovent[®] products are sold with standard limited warranty, copy of which is available at our main office.

PART 2 PRODUCTS

2.01 Manufacturers

- A. Explovent pressure relief panel systems shall be manufactured by Conspec Systems, Inc., Cranford, NJ; or C/S Construction Specialties Company, Mississauga, Ontario.
- C. Each panel shall be shop calibrated and tested for proper operation and for release at the design loads specified on the approved drawing.
- D. All panels shall be permanently marked with the design release pressure and the maximum static release force.
- E. Manufacturer shall have complete in-house finishing capabilities.

2.02 Materials

- A. Panels shall be 63" (16mm) thick translucent solar grade polycarbonate extruded structured sheet. Material shall be classified as CC-2 per ASTM-D635. Color to be clear.

B. Panel framing components shall be .063" (1.6mm) 6063-T52 alloy extruded aluminum.

C. All fasteners shall be aluminum or stainless steel.

D. Exterior panel gaskets shall be a pile fiber type with a continuous polypropylene center fin.

E. Interior gaskets shall consist of open cell compression foam and clad with a polyethylene liner.

2.03 Fabrication

- A. Fabricate the pressure relief panels model ERP-T-PC or ERP-B-PC to the sizes shown on the approved shop drawings.
- B. Panels shall be top or bottom hinged as detailed.
- C. All panels, frames, and release mechanisms shall be factory assembled in units and shipped to the job site.
- D. Head, sill, jamb, and mullion frame members to be one piece extruded aluminum structural members as detailed, and to have integral caulking slots. Mullions to be two-piece interlocking assemblies, which allow for expansion and contraction, and for individual panel removeability.
- E. All panels shall have exterior pile gaskets and interior compression (or magnet) gaskets to minimize air leakage and water entrainment when closed.
- F. The release mechanism shall be mounted to the panel frame, and shall be shop calibrated and tested for the design loads specified on approved drawings.

2.02 Factory Finishing

- A. Duracron Super 600[®]: Panels and frames shall be finished with a thermosetting acrylic costing. Total coating to be minimum 0.8 mil (0.02mm) thick.
- B. Kynar 500[®]: Panels and frames shall be finished in full strength, 70% resin Kynar 500[®] Fluoropolymer Coating consisting of prime coat and color coat minimum 1 mil (0.025mm) thick.
- C. Colors to be selected from manufacturers standard color selection.

PART 3 EXECUTION

3.01 Installation

- A. The vents must be installed in accordance with shop drawings, the installation instructions, and any special instructions on the shop drawing.

C/S GROUP OF COMPANIES

MANUFACTURING/SALES/DISTRIBUTION LOCATIONS

U.S.A. Conspec Systems, Inc., Cranford, NJ Tel:(800)222-0201 Fax:(800)293-4509

Canada C/S Construction Specialties Company, Mississauga, Ont. Tel:(905)274-3611 Fax:(905)274-6241

For Phone Number of Nearest Representative, Call Toll Free (800)222-0201 (U.S.A.) and (888)895-8955 (Canada only).

For Assistance with Overseas Requirements, Fax C/S International (908)236-2903.

©Copyright 2001 Conspec Systems, Inc. Reserves the Right to Make Design Changes or to Withdraw Any Design Without Notice.

Printed in U.S.A.