

MODEL GFP & GFPW - HD INSTALLATION INSTRUCTIONS

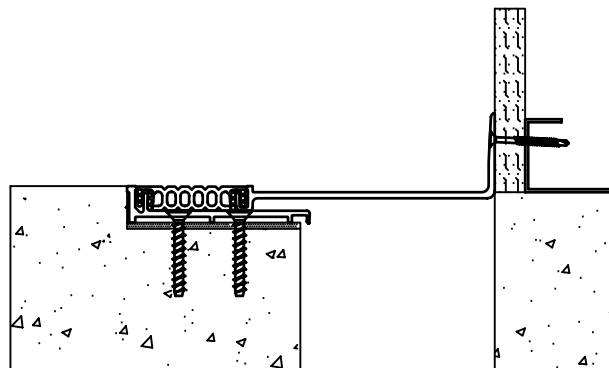
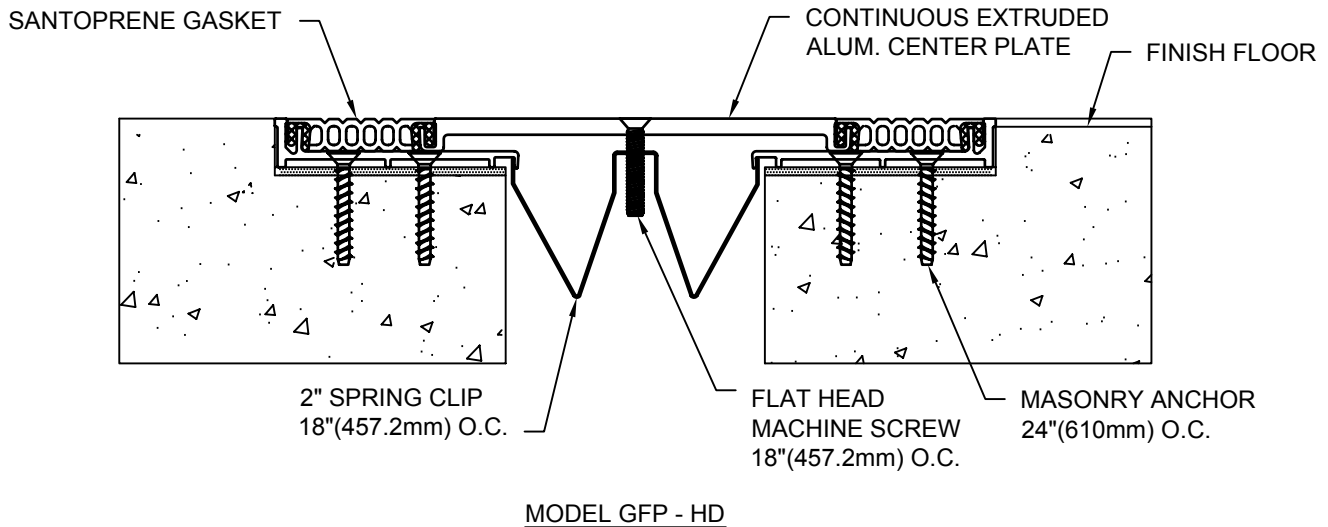

IMPORTANT INFORMATION

Prior to the commencement of Installation, all materials **MUST** be inspected for Damage. Any damage must be reported to CONSTRUCTION SPECIALTIES, INC., as soon as possible, so that replacement materials may be furnished without delay.

All work must be completed as per Architect's Approved "Shop Drawings", and in accordance with these Installation Instructions. When installation is complete, all materials must be protected from damage until the Architect's FINAL INSPECTION.

All materials should be arranged in the order that they are to be installed. All hardware required for each portion of the work should be placed with the appropriate materials.

Please review all Approved Shop Drawings and this Document to familiarize yourself with all the details and components of this assembly.

IMPORTANT:

READ THROUGH ALL INSTRUCTIONS PRIOR TO STARTING INSTALLATION

9/16/05

CONSTRUCTION SPECIALTIES, INC.

P.O. BOX 380
MUNCY, PA 17756
PHONE: (570)546-5941 FAX: (570)546-8022

This document is the property of Construction Specialties, Inc. and contains CONFIDENTIAL PROPRIETARY INFORMATION that is not to be disclosed to third parties and is not to be used without approval in writing from Construction Specialties, Inc.

Notes:

Before beginning installation, review the architectural drawings and approved Construction Specialties Inc. shop drawings to familiarize yourself with the joint cover models and locations.

Check all of the joint cover components to confirm that the correct joint cover model and size have been received. Also, check for materials that may have been damaged during shipping. Report all incorrect and/or damaged components to C/S at 800-233-8493.

Read through all the steps of these instructions prior to beginning work.

STEP 1

PREPARE BLOCKOUT

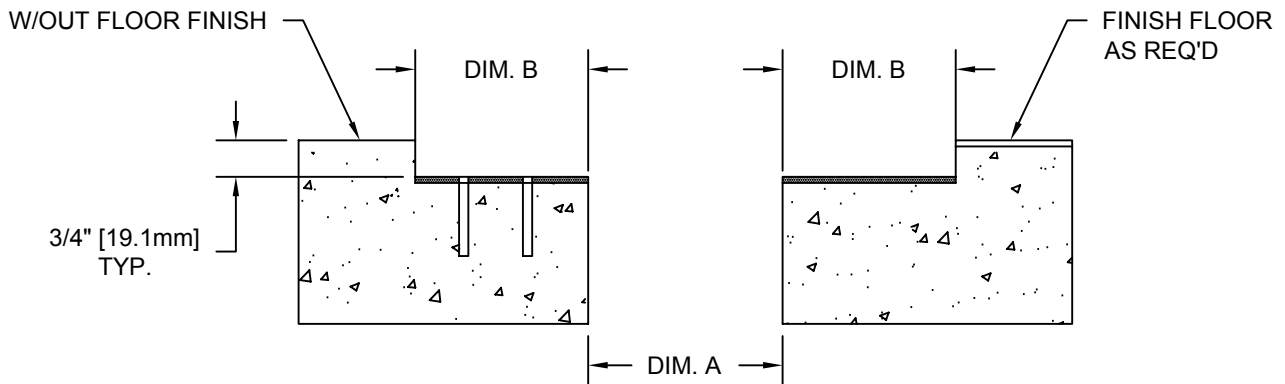

BLOCKOUT DIMENSIONS	
DIM. A	DIM. B
2" [50.8mm]	2-5/16" [58.7mm]
3" [76.2mm]	3-9/16" [90.5mm]
4" [101.6mm]	3-9/16" [90.5mm]

- 1.1) The blockouts must be prepared to receive the joint cover.
 - The blockout width (Dim. B) will vary with model as indicated above or as noted on the C/S shop drawings.
 - The blockout depth will typically be 3/4"(19.1mm). However, the depth may be adjusted as needed to accommodate a floor finish material when required and as indicated on the architectural drawings and/or C/S shop drawings.
 - It is recommended that the blockout be formed a minimum of 1/8" deeper to allow the blockouts to be leveled for installation of the joint cover.
 - Apply a high-strength leveling grout to the base of the blockouts to provide a continuous, solid, flat and level base for the joint cover. (Note: The blockouts must be level across the width of the joint.)

STEP 2

FRAME INSTALLATION

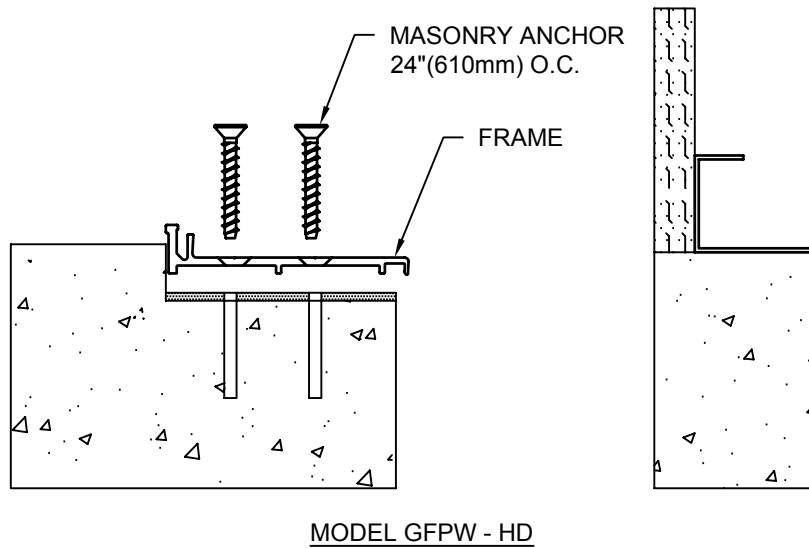
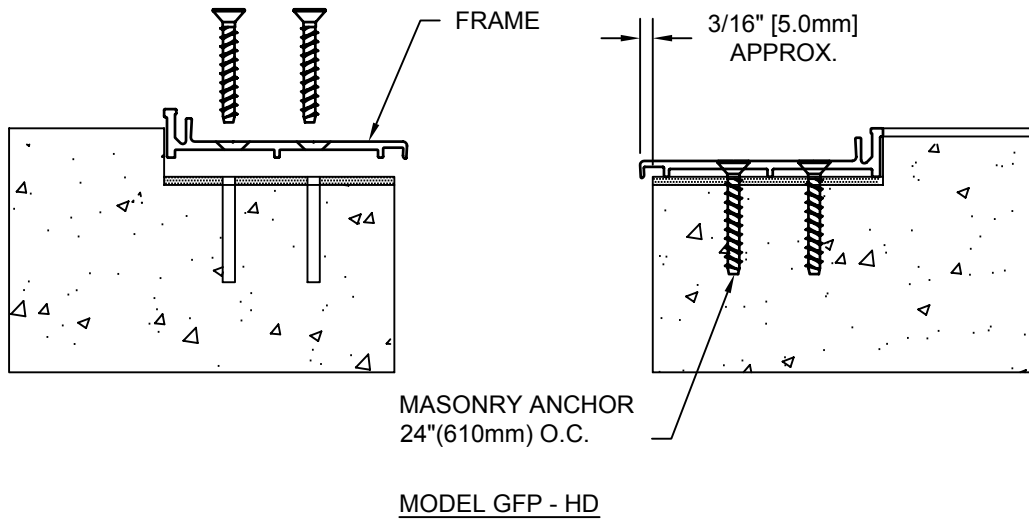

Note:

If a C/S Fire Barrier is to be installed in the joint, please review the Fire Barrier Installation Instructions supplied, and if required install the Fire Barrier **BEFORE** installation of C/S Seismic Expansion Joint Aluminum Frames. If a Waterstop is to be installed in the joint, please review the Waterstop Installation Instructions supplied, and if required install the Waterstop **BEFORE** installation of C/S Seismic Expansion Joint Aluminum Frames.

- 2.1) Begin installation of the Frames by placing a length of Frame into the blockout. Cut the Frame to length as needed. The Frame is to sit level, flat and parallel to the edge of the joint. Note: The Frame is to overhang the edge of the joint by approx. 3/16"(5mm).
- 2.2) Using the Frame as a template, mark the locations of the Frame anchor bolts.
- 2.3) Remove the Frame and drill the holes for the anchor bolts. The holes are to be drilled with the appropriate size and type of drill bit as indicated by the manufacturer of the C/S supplied anchor bolts.
- 2.4) Reposition and anchor the Frame to the slab with the C/S supplied anchor bolts following the manufacturer's guidelines.
- 2.5) Repeat the installation procedure for the opposite side of the joint and any additional lengths of Frame.

STEP 3

CENTER PLATE INSTALLATION

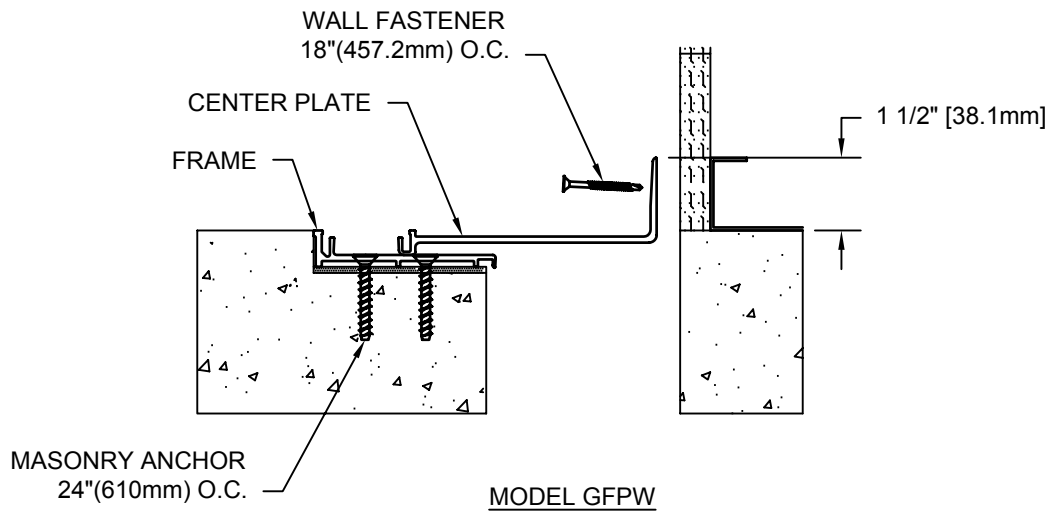
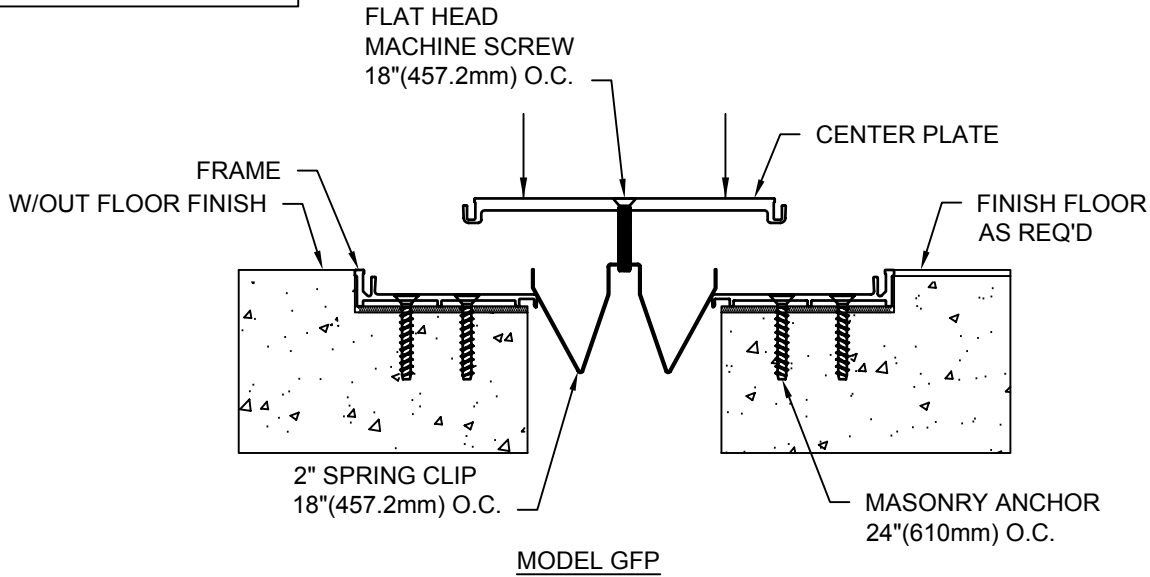

- 3.1) Attach the spring clips to the Center Plate using the supplied flat head machine screws. Screw the fastener into the clips just enough to keep the clips from falling off. Do not tighten the fasteners at this time.
- 3.2) Position the Center Plate over the expansion joint, with the spring clip resting on the Frames as shown. Push down evenly on the Center Plate until you hear a "snap," indicating that the clip has engaged within the joint. To further ensure that the clip has engaged within the joint, drive the fastener down until it bottoms out on the Center Plate and nests in the countersunk hole. At this point, tighten the fastener.

Note: Since it is important that the clips be properly locked in the Frames, you may verify engagement by doing the following:

- a. Determine if the screw head is running parallel with the plane of the Center Plate. If the head appears to be at an angle, it is likely that one side of the clip is not locked in place.
- b. Another way to check the clip is to back the fastener out roughly half way and attempt to drive the fastener and clip assembly down. If it is difficult to move, this is a sign that the clip is correctly installed.

Floor to Wall Applications:

- 3.1w) Measure 1-1/2"(38.1mm) above slab surface and mark a line on the wall surface.
- 3.2w) Align the top of the vertical flange of the Center Plate with the line .
- 3.3w) Attach the Center Plate with supplied wall fasteners 18"(457.2mm) o.c.

STEP 4

GASKET INSTALLATION

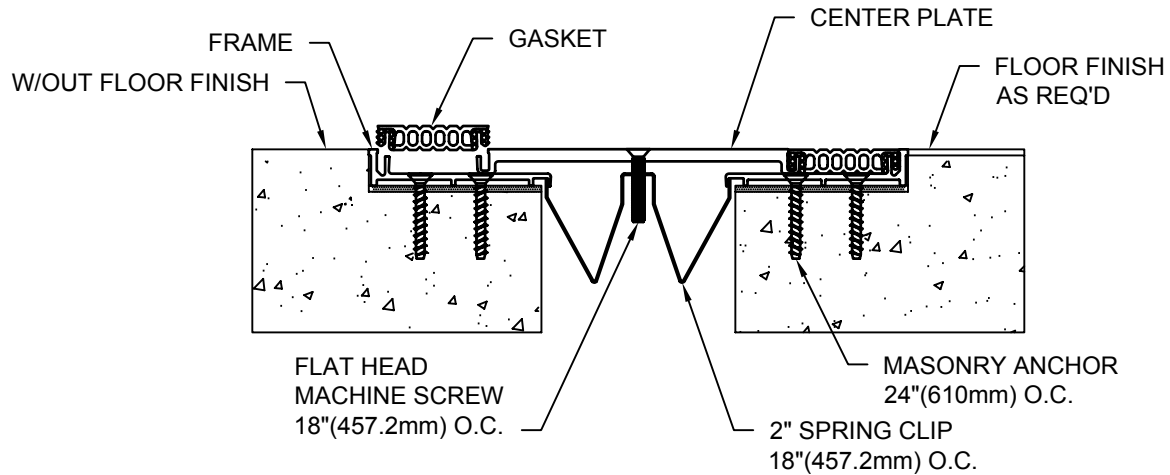

MODEL GFP - HD

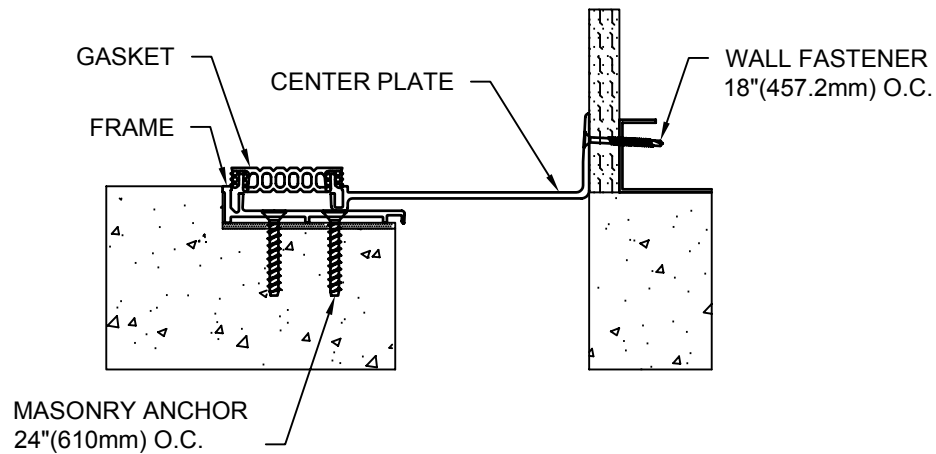

MODEL GFPW - HD

- 4.1) Complete the installation by inserting the gaskets. It may be necessary to drive the gasket in place using a rubber mallet and a wood block. Lubricating the push in areas by spraying them with a light mist of water will also ease the installation. When gaskets are properly installed, they should be flush with the top surface of the Center Plate and Frames.

Tip: If you spray the push in arrow with soapy water, the Gasket slides in much easier.

STEP 5

COMPLETE INSTALLATION

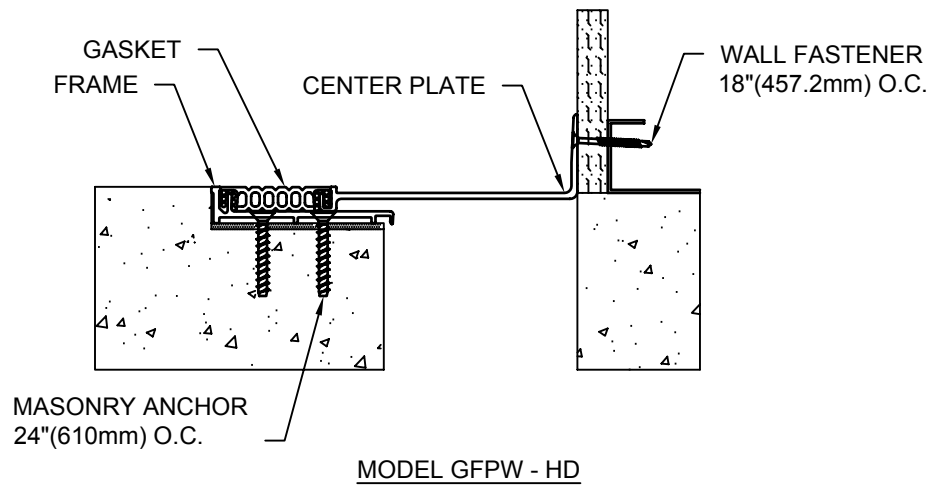
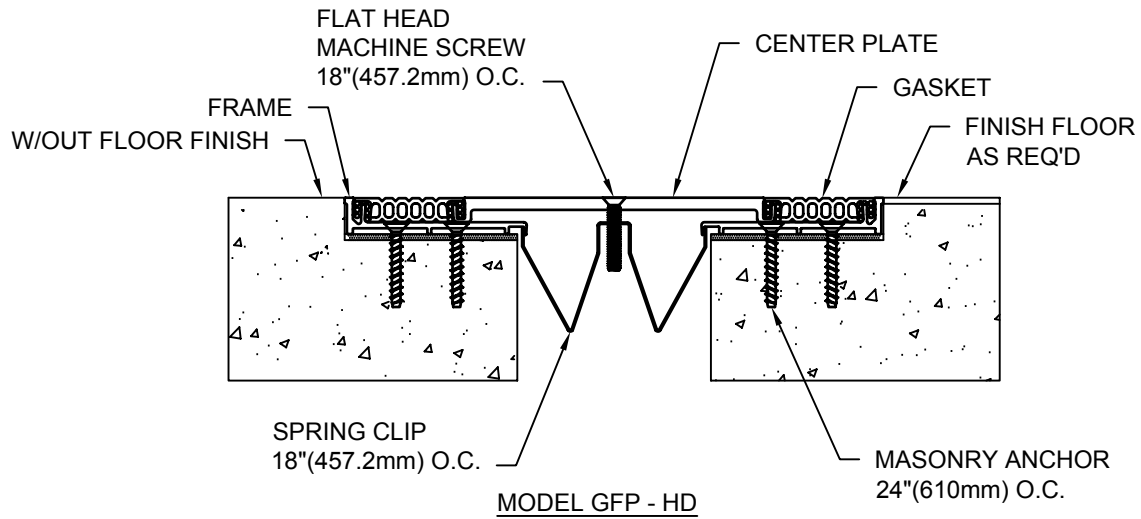

- 5.1) When installation of the C/S Floor Expansion Joint Cover has been completed, remove all residue and foreign matter from the area and joint cover.
- 5.2) Clean the C/S Joint Cover and adjoining surfaces with proper cleaner.
- 5.3) Protect the Joint Cover until the Architect's final inspection.