

MODEL SJP-200 THRU 1600 INSTALLATION INSTRUCTIONS

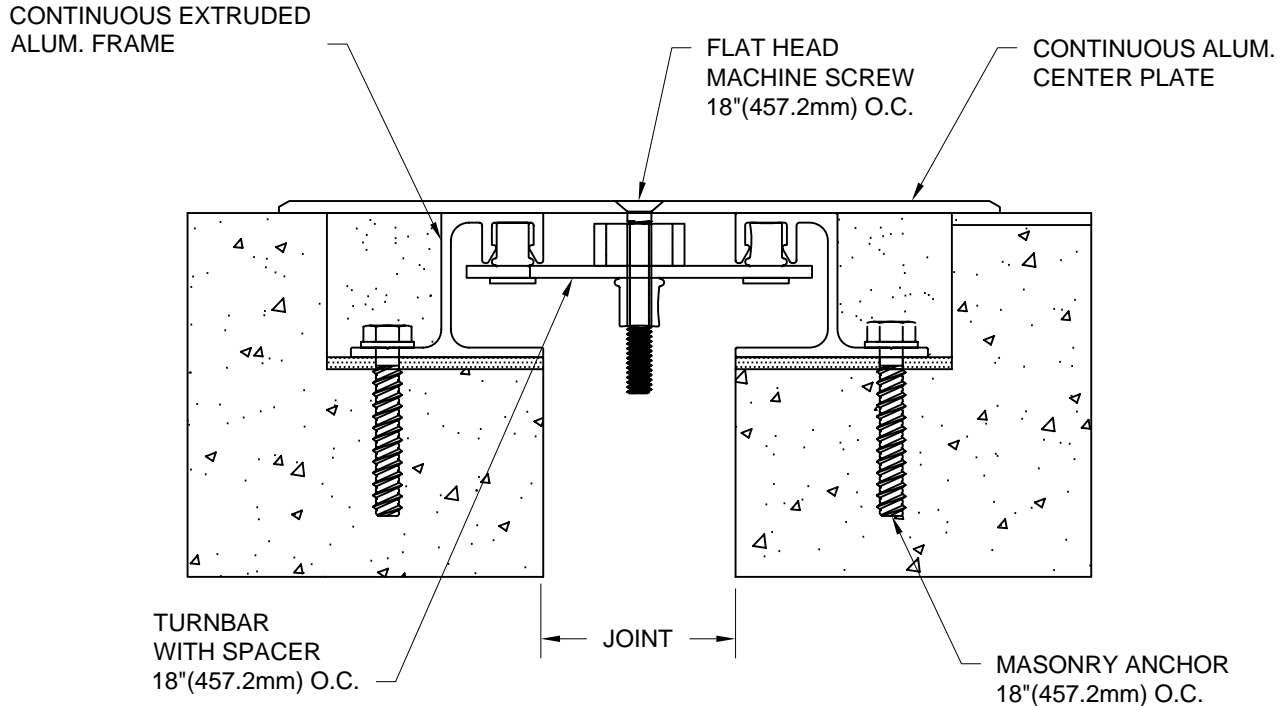

IMPORTANT INFORMATION

Prior to the commencement of Installation, all materials **MUST** be inspected for Damage. Any damage must be reported to CONSTRUCTION SPECIALTIES, INC., as soon as possible, so that replacement materials may be furnished without delay.

All work must be completed as per Architect's Approved "Shop Drawings", and in accordance with these Installation Instructions. When installation is complete, all materials must be protected from damage until the Architect's FINAL INSPECTION.

All materials should be arranged in the order that they are to be installed. All hardware required for each portion of the work should be placed with the appropriate materials.

Please review all Approved Shop Drawings and this Document to familiarize yourself with all the details and components of this assembly.

IMPORTANT:

READ THROUGH ALL INSTRUCTIONS PRIOR TO STARTING INSTALLATION

3/23/07

CONSTRUCTION SPECIALTIES, INC.

P.O. BOX 380
MUNCY, PA 17756
PHONE: (570)546-5941 FAX: (570)546-8022

This document is the property of Construction Specialties, Inc. and contains CONFIDENTIAL PROPRIETARY INFORMATION that is not to be disclosed to third parties and is not to be used without approval in writing from Construction Specialties, Inc.

Notes:

Before beginning installation, review the architectural drawings and approved Construction Specialties Inc. shop drawings to familiarize yourself with the appropriate joint cover models and locations.

Check all of the joint cover components to confirm that the correct joint cover model and size have been received. Also, check for materials that may have been damaged during shipping. Report all incorrect and/or damaged components to C/S at 800-233-8493.

Read through all the steps of these instructions prior to beginning work.

STEP 1

PREPARE BLOCKOUTS

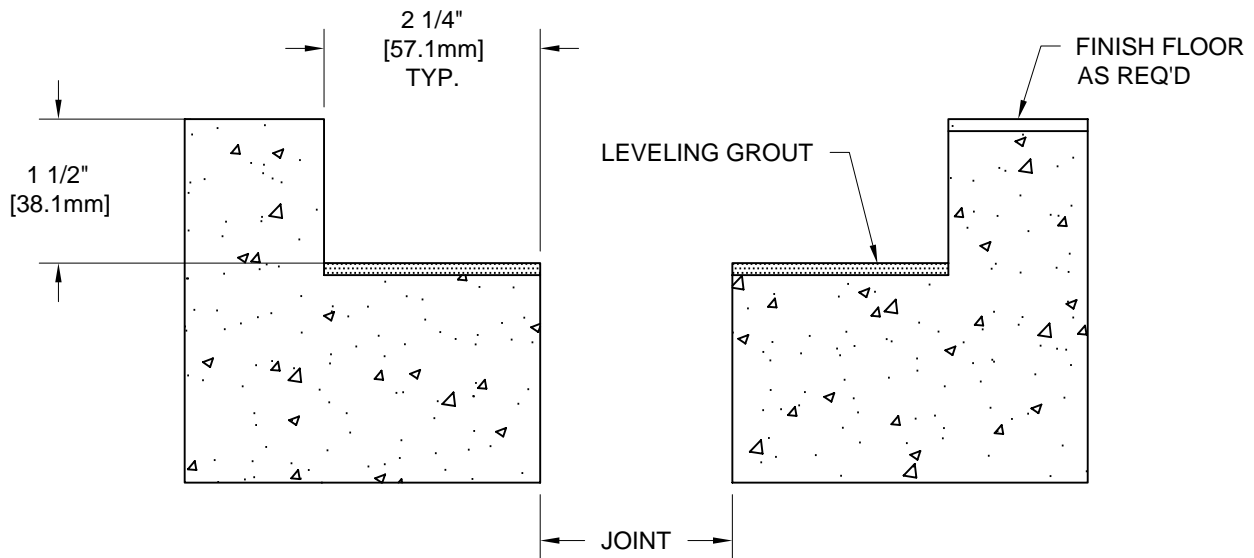

1.1) The blockouts must be prepared to receive the joint cover.

- For Model SJP the blockout depth will typically be 1-1/2"(38.1mm). However, the depth may be adjusted as needed to accommodate a floor finish material when required and as indicated on the architectural drawings and/or C/S shop drawings.
- It is recommended that the blockout be formed a minimum of 1/8" deeper to allow the blockouts to be leveled for installation of the joint cover.
- Apply a high-strength leveling grout to the base of the blockouts to provide a continuous, solid, flat and level base for the joint cover. (Note: The blockouts must be level across the width of the joint.)

STEP 2

SPACER INSTALLATION

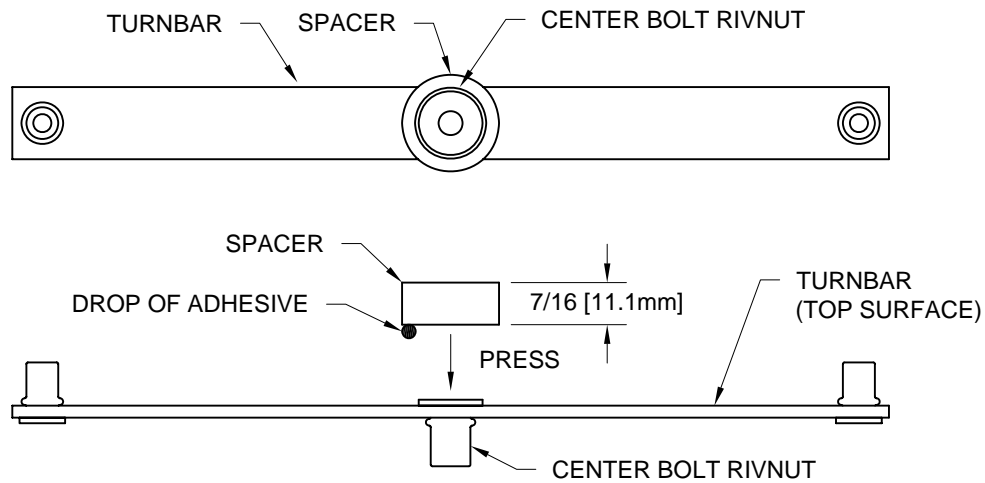

A Spacer must be placed between the Turnbar and the underside (or backside) of the cover plate. The Spacer is used to prevent excess bowing of the Turnbars when the center bolt is tightened. (Some bowing of the Turnbars is required to apply the holding force on the cover plate.)

Spacer Installation:

- 2.1) Place a small drop of "super glue" adhesive (not supplied) onto one end of a Spacer.
- 2.2) Position the end of the Spacer with the adhesive against the top surface of the Turnbar, centered over the flat head portion of the Center Bolt Rivnut. (See detail above.)
- 2.3) Press firmly for a few seconds until the Spacer is bonded to the Turnbar.
- 2.4) Install the Turnbars as instructed.

STEP 3

BASE FRAME INSTALLATION

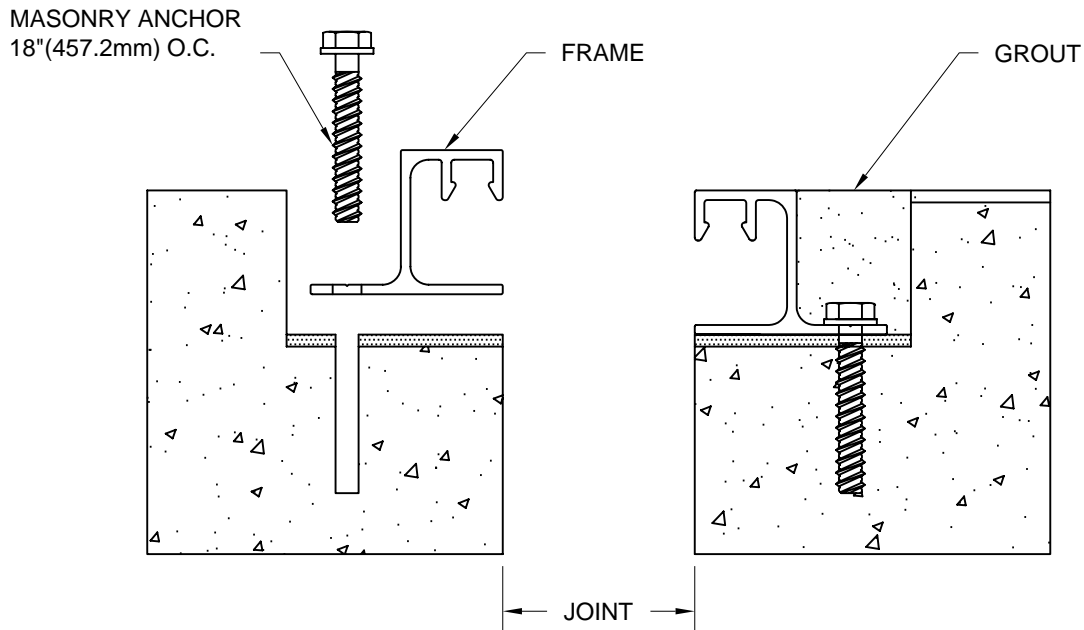

Note:

If a C/S Fire Barrier is to be installed in the joint, please review the Fire Barrier Installation Instructions supplied, and if required install the Fire Barrier **BEFORE** installation of C/S Seismic Expansion Joint aluminum frames. If a Waterstop is to be installed in the joint, please review the Waterstop Installation Instructions supplied, and if required install the Waterstop **BEFORE** installation of C/S Seismic Expansion Joint Aluminum Frames.

- 3.1) Begin installation of the Frame by placing a length of Frame into the blockout. Cut the Frame to length as needed. The Frame is to sit level, flat and parallel to the edge of the joint. The Frame should not overhang the edge of the slab or sit above the top surface of the slab.
- 3.2) Using the Frame as a template, mark the locations in the blockout for the anchor bolts. Remove the Frame and drill the holes for the anchor bolts. The holes are to be drilled with the appropriate size and type of drill bit as indicated by the manufacturer of the anchor bolts, as supplied by C/S.
- 3.3) Reposition the Frame and anchor the Frame to the slab with the C/S supplied anchor bolts following the manufacturer's guidelines.
- 3.4) Repeat the installation procedures for any additional lengths of Frame or the Frame at the opposite side of the joint if required.
- 3.5) Apply grout in blockout on both sides of the expansion joint using an epoxy cement grout. The grout must be poured level with the blockout.

STEP 4

CENTER PLATE INSTALLATION

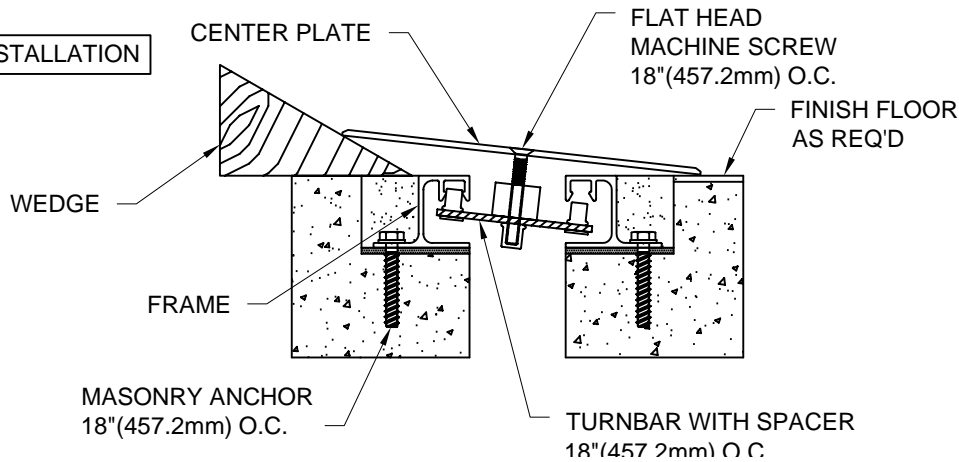

Note: Install floor finish (if req'd) prior to installation of Center Plate.

- 4.1) Prepare the Center Plate for installation by first cutting the Plate to length as needed.
- 4.2) Attach a Turnbar to the backside of the Center Plate at each hole location. (Note the orientation of the Turnbar in the detail above.) Thread a machine screw only approx. 1/4" into the Turnbar for now.
- 4.3) Place the Center Plate/Turnbar Assembly against one side of the Seismic Expansion Joint at an angle that will allow hand penetration behind the Center Plate. With the Center Plate in this position, reach behind the Center Plate and locate the pivot pin of the end Turnbar into the pivot pin receivers of the Frame on each side of the joint.
- 4.4) Slide a wedge block beneath the Center Plate to hold the Turnbar securely into position.
- 4.5) Repeat this procedure with the Turnbar at the opposite end of the Center Plate.
- 4.6) Locate each of the remaining Turnbars into position, then progressively tighten all machine screws until the Center Plate is securely fastened onto the Frame system. (Note: The Turnbars should all be angled the same direction.)

STEP 5

COMPLETE INSTALLATION

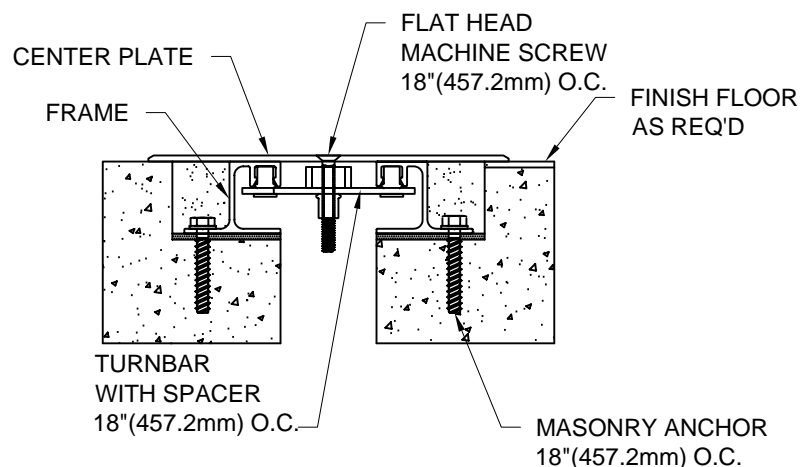

- 5.1) When installation of the Joint Cover has been completed, remove all residue and foreign matter from the area and joint cover.
- 5.2) Clean the C/S Joint Cover and adjoining surfaces with proper cleaner.
- 5.3) Protect the Joint Cover until the Architect's final inspection.