

MODEL SGW/SGWC 500 THRU 1600 INSTALLATION INSTRUCTIONS

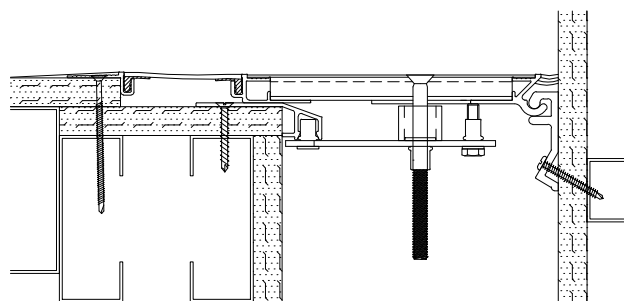
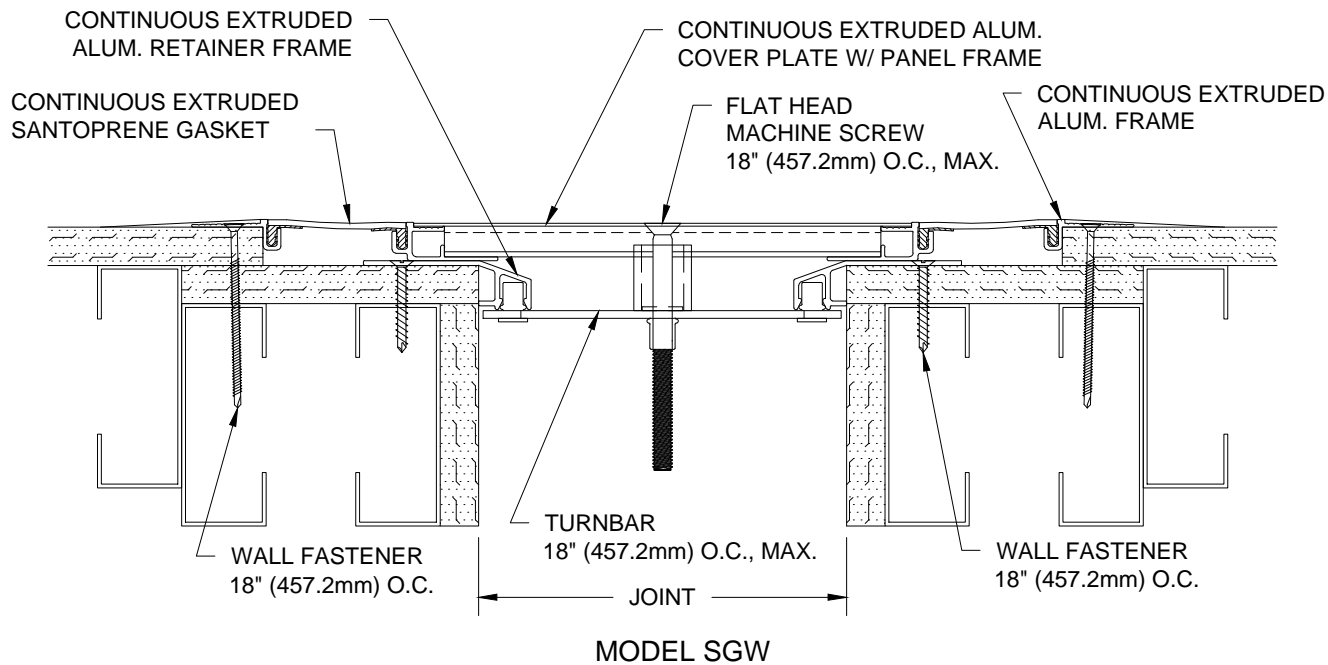

IMPORTANT INFORMATION

Prior to the commencement of Installation, all materials MUST be inspected for Damage. Any damage must be reported to CONSTRUCTION SPECIALTIES, INC., as soon as possible, so that replacement materials may be furnished without delay.

All work must be completed as per Architect's Approved "Shop Drawings", and in accordance with these Installation Instructions. When installation is complete, all materials must be protected from damage until the Architect's FINAL INSPECTION.

All materials should be arranged in the order that they are to be installed. All hardware required for each portion of the work should be placed with the appropriate materials.

Please review all Approved Shop Drawings and this Document to familiarize yourself with all the details and components of this assembly.

IMPORTANT:

READ THROUGH ALL INSTRUCTIONS PRIOR TO STARTING INSTALLATION

1/26/12

CONSTRUCTION SPECIALTIES, INC.

P.O. BOX 380
MUNCY, PA 17756
PHONE: (570)546-5941 FAX: (570)546-8022

This document is the property of Construction Specialties, Inc. and contains CONFIDENTIAL PROPRIETARY INFORMATION that is not to be disclosed to third parties and is not to be used without approval in writing from Construction Specialties, Inc.

Notes:

Before beginning installation, review the architectural drawings and approved Construction Specialties Inc. shop drawings to familiarize yourself with the joint cover models and locations.

Check all of the joint cover components to confirm that the correct joint cover model and size have been received. Also, check for materials that may have been damaged during shipping. Report all incorrect and/or damaged components to C/S at 800-233-8493.

Read through all the steps of these instructions prior to beginning work.

STEP 1

PREPARE BLOCKOUTS

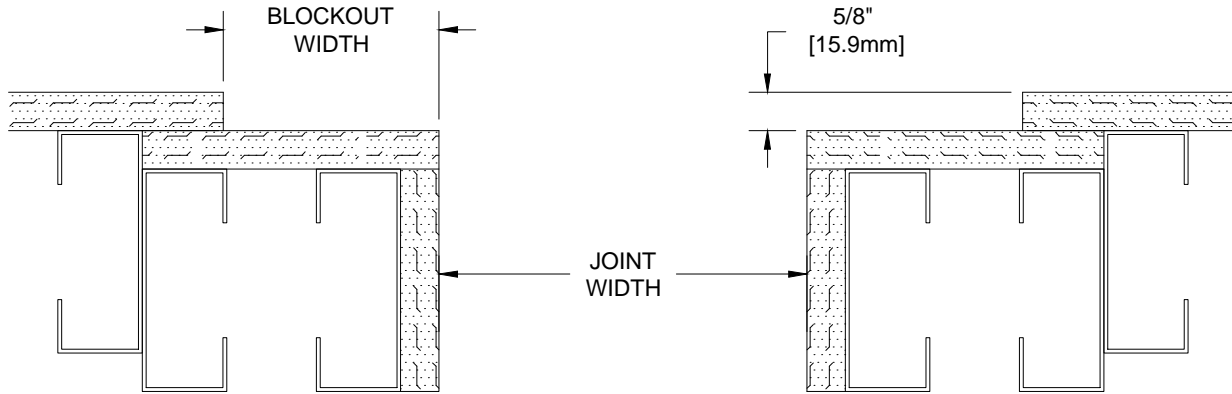

Step 1:

- 1.1) The blockouts must be prepared to receive the joint cover.
 - The blockout width will vary with model as noted on the C/S shop drawings.
 - The blockout depth will typically be 5/8" (15.9mm).

STEP 2

SPACER INSTALLATION

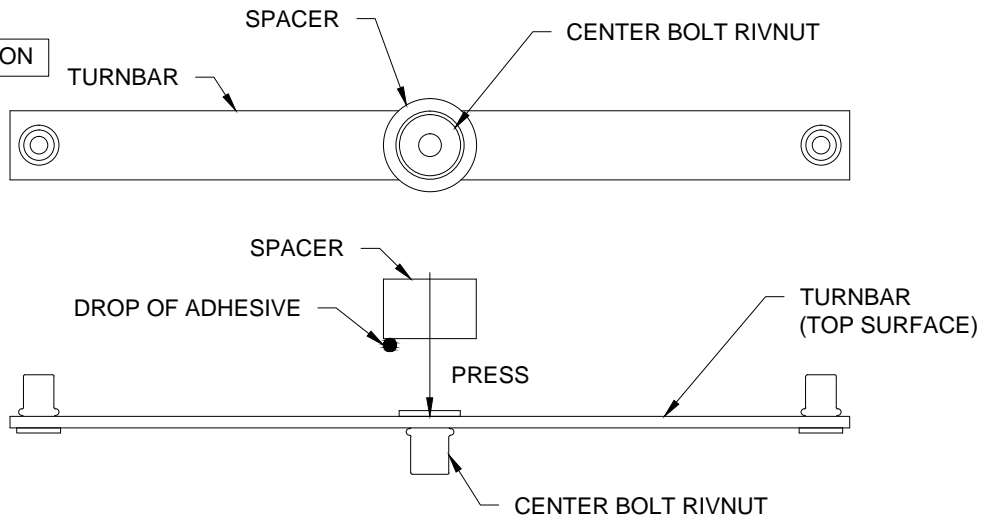

Step 2:

Notes: A Spacer must be placed between the Turnbar and the underside (or backside) of the Cover Plate. The Spacer is used to prevent excess bowing of the Turnbars when the center bolt is tightened. (Some bowing of the Turnbars is required to apply the holding force on the Cover Plate.)

- 2.1) Place a small drop of "super glue" adhesive (not supplied) onto one end of a Spacer.
- 2.2) Position the end of the Spacer with the adhesive against the top surface of the Turnbar, centered over the flat head portion of the Center Bolt Rivnut (see detail above).
- 2.3) Press firmly for a few seconds until the Spacer is bonded to the Turnbar.

STEP 3

FRAME INSTALLATION

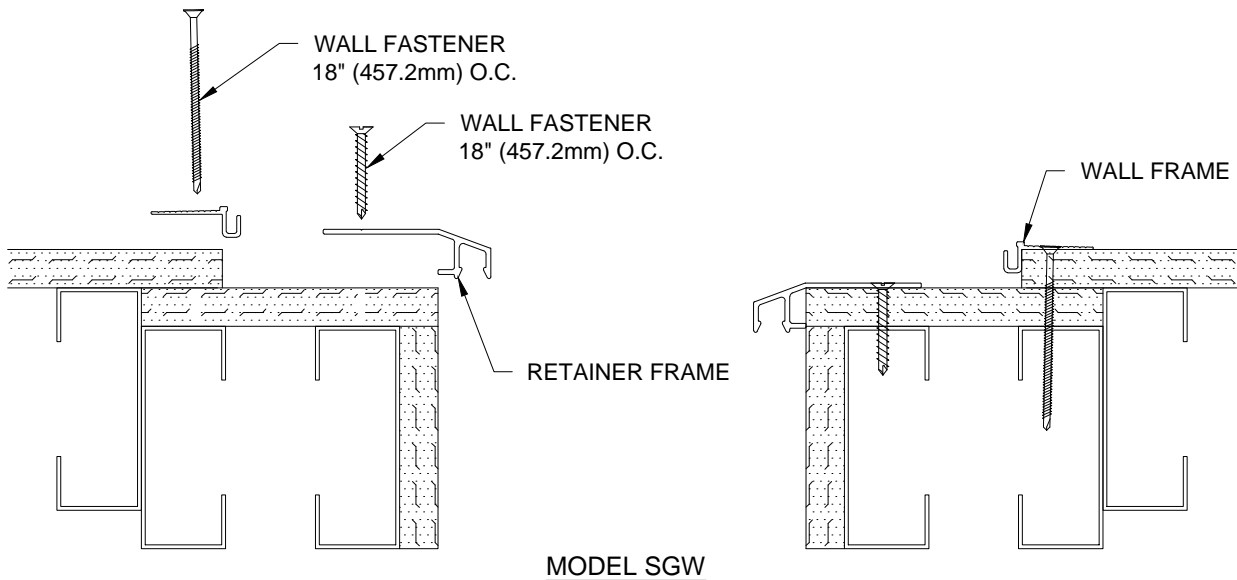

Step 3:

Note: If a C/S Fire Barrier is to be installed in the joint, please review the Fire Barrier Installation Instructions supplied, and if required install the Fire Barrier **BEFORE** installation of C/S Seismic Expansion Joint Aluminum Frames.

- 3.1) Begin installation of Wall Frame by placing a length of the Frame onto edge of blockout as shown above. Cut the Frame to length as needed.
- 3.2) Position the Frame as shown above and anchor the Frame to the wall using the C/S supplied wall fasteners per approved shop drawings and in accordance with the manufacturer's guidelines.

Note: Depending on wall construction, it may be necessary to pre-drill holes for the C/S supplied fasteners.

- 3.3) Repeat this installation procedure on opposite side of joint and for any additional lengths of Wall Frame.
- 3.4) Begin installation of Retainer Frame by placing a length of the Retainer Frame onto edge of blockout as shown above. Cut the Retainer Frame to length as needed.
- 3.5) Position the Retainer Frame as shown above and anchor the Retainer Frame to the wall using the C/S supplied wall fasteners per approved shop drawings and in accordance with the manufacturer's guidelines.

Note: Depending on wall construction, it may be necessary to pre-drill holes for the supplied fasteners.

- 3.6) Repeat this installation procedure on opposite side of joint and for any additional lengths of Retainer Frame.

STEP 4

CORNER FRAME INSTALLATION

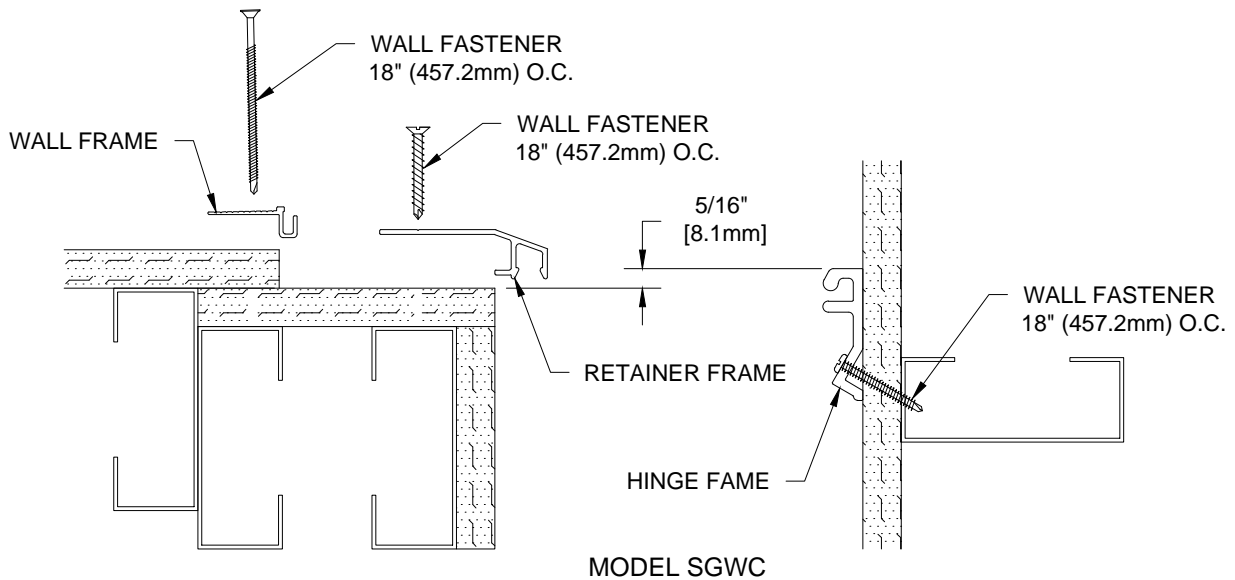

Step 4:

Note: If a C/S Fire Barrier is to be installed in the joint, please review the Fire Barrier Installation Instructions supplied, and if required install the Fire Barrier BEFORE installation of C/S Seismic Expansion Joint Aluminum Frames.

- 4.1) Begin installation of Wall Frame by placing a length of the Frame onto edge of blockout as shown above. Cut the Wall Frame to length as needed.
- 4.2) Position the Wall Frame as shown above and anchor the Wall Frame to the wall using the C/S supplied wall fasteners per approved shop drawings and in accordance with the manufacturer's guidelines.

Note: Depending on wall construction, it may be necessary to pre-drill holes for the C/S supplied fasteners.

- 4.3) Repeat this installation procedure for any additional lengths of Wall Frame.
- 4.4) Begin installation of Retainer Frame by placing a length of the Retainer Frame onto edge of blockout as shown above. Cut the Retainer Frame to length as needed.
- 4.5) Position the Retainer Frame as shown above and anchor the Retainer Frame to the wall using the C/S supplied wall fasteners per approved shop drawings and in accordance with the manufacturer's guidelines.

Note: Depending on wall construction, it may be necessary to pre-drill holes for the C/S supplied fasteners.

- 4.6) Repeat this installation procedure for any additional lengths of Retainer Frame.
- 4.7) Begin installation of Hinge Frame by cutting the Hinge Frame to length as needed.
- 4.8) Measure 5/16" above blockout surface and mark a line on wall surface. Align the top of Hinge Frame with line on surface of wall as shown in detail above.
- 4.9) Anchor the Hinge Frame to the wall using the C/S supplied wall fasteners per approved shop drawings and in accordance with the manufacturer's guidelines.

Note: Depending on wall construction, it may be necessary to pre-drill holes for the C/S supplied fasteners.

- 4.10) Repeat this installation procedure for any additional lengths of Hinge Frame.

STEP 5

COVER PLATE INSTALLATION

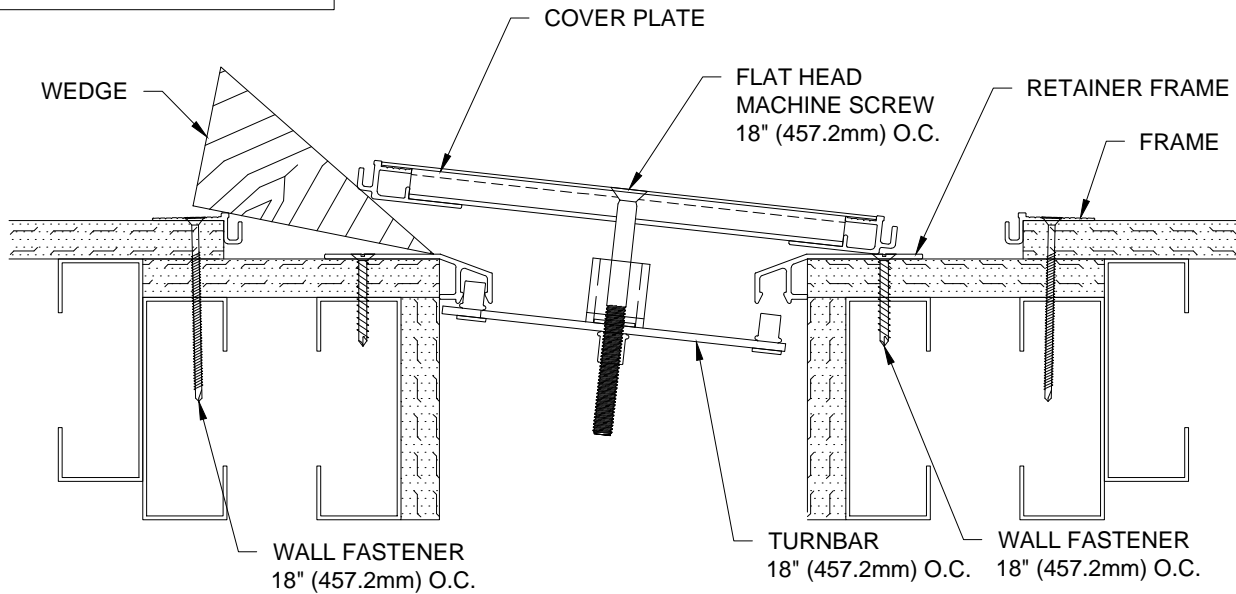

MODEL SGW

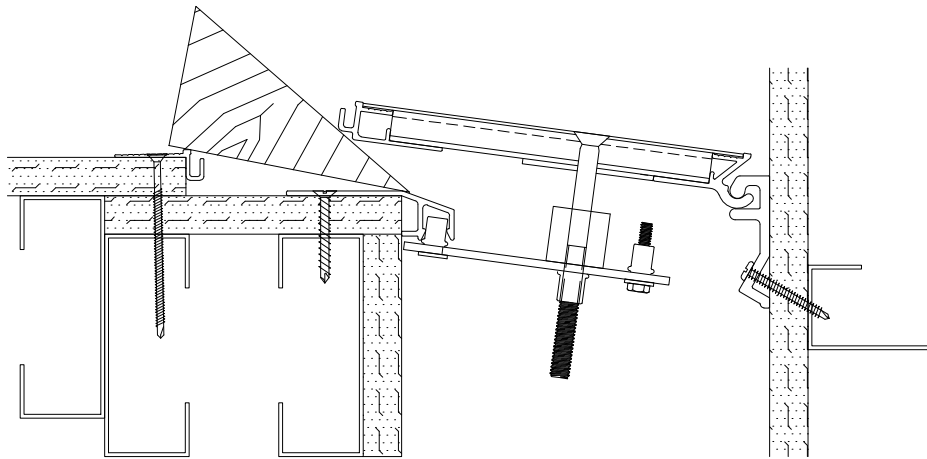

MODEL SGWC

Step 5:

- 5.1) Prepare the Cover Plate for installation by first cutting the Plate to length as needed.
- 5.2) Attach a Turnbar to the backside of the Cover Plate at each hole location. (Note the orientation of the Turnbar in the detail above.) Thread a machine screw only approx. 1/4" into the Turnbar for now.
- 5.3) Place the Cover Plate/Turnbar Assembly against one side of the Seismic Expansion Joint at an angle that will allow hand penetration behind the Cover Plate. With the Cover Plate in this position, reach behind the Cover Plate and locate the pivot pin of the end Turnbar into the pivot pin receivers of the Frame on each side of the joint.
- 5.4) Slide a wedge block beneath the Cover Plate to hold the Turnbar securely into position.
- 5.5) Repeat this procedure with the Turnbar at the opposite end of the Cover Plate, if necessary.
- 5.6) Locate each of the remaining Turnbars into position, then progressively tighten all machine screws until the Cover Plate is securely fastened onto the Frame system. (**Note: The Turnbars must be angled the same direction to allow for movement.**)
- 5.7) Repeat this installation procedure for any additional lengths of Cover Plate.

STEP 6

GASKET INSTALLATION

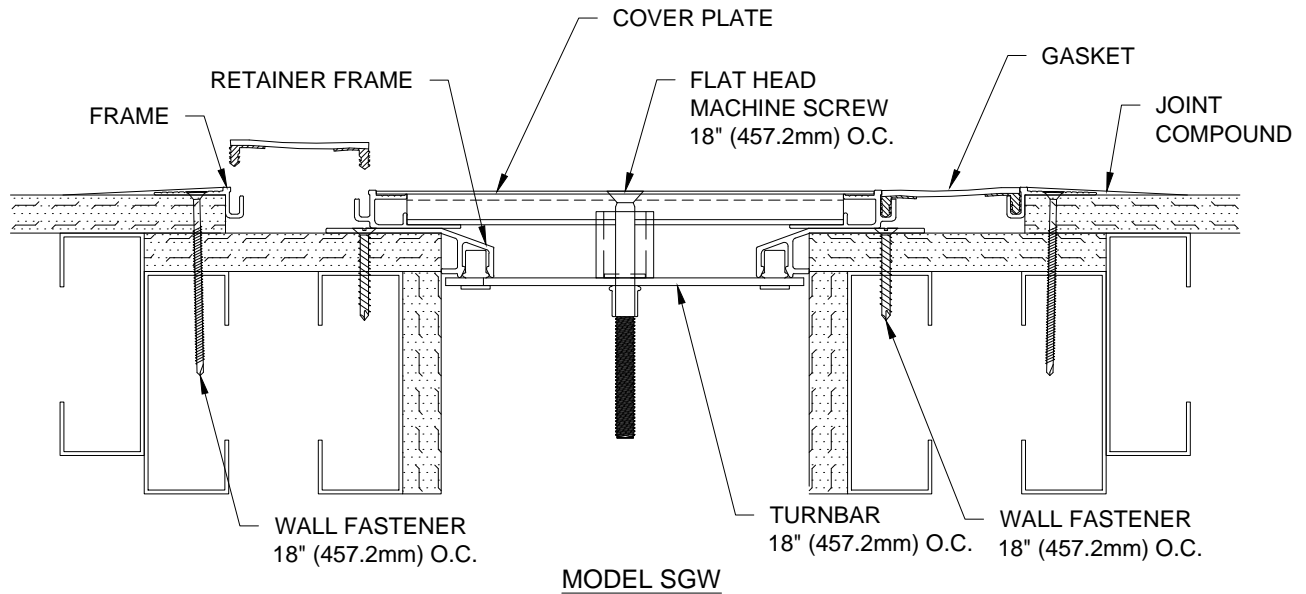

MODEL SGW

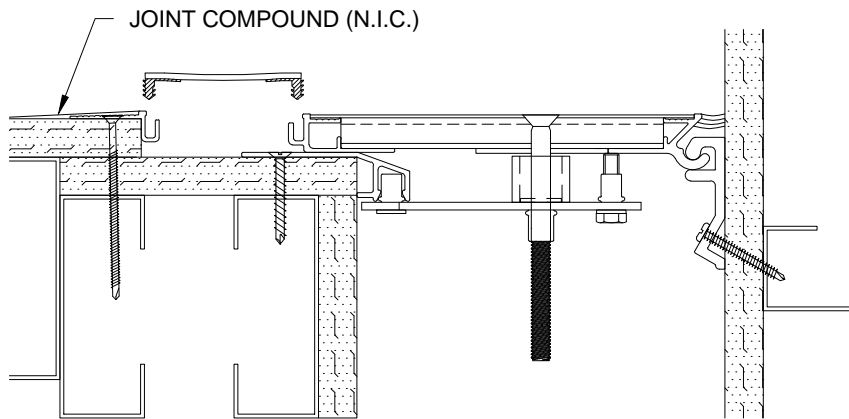

MODEL SGWC

Step 6:

- 6.1) Complete the installation by inserting the Gaskets. It may be necessary to drive the Gasket in place using a rubber mallet and a wood block. Lubricating the push in areas by spraying them with a light mist of water will also ease the installation. When Gaskets are properly installed, they should be flush with the top surface of the Cover Plate and Frames.

Tips: If capable prior to installation, unroll the Gasket material and allow exposure to the sun until the material softens and becomes more pliable (approx. 30 minutes).

Also, if you spray the push in arrow with soapy water, the Gasket slides in much easier.

- 6.2) Apply joint compound (by others) as shown in detail above.

STEP 7

COMPLETE INSTALLATION

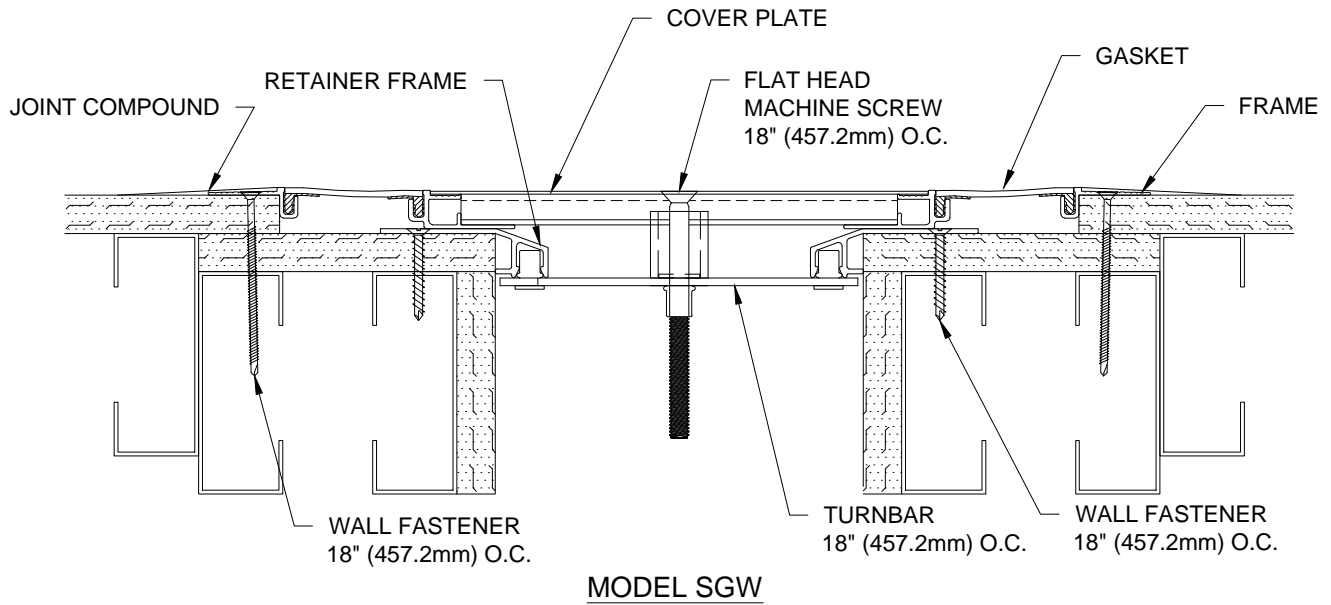

MODEL SGW

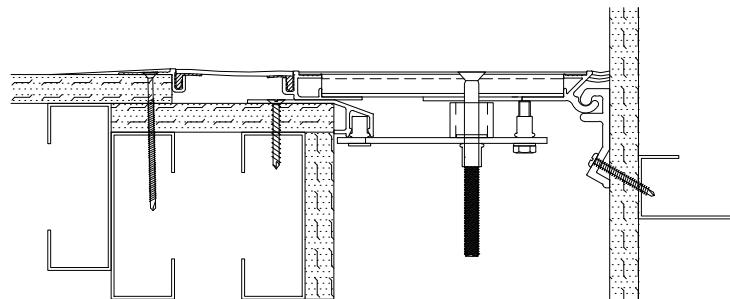

MODEL SGWC

Step 7:

- 7.1) When installation of the C/S Wall Expansion Joint Cover has been completed, remove all residue and foreign matter from the area and joint cover.
- 7.2) Clean the C/S Joint Cover and adjoining surfaces with proper cleaner.
- 7.3) Protect the Joint Cover until the Architect's final inspection.