

MODEL "KBC" & "KBCW" INSTALLATION INSTRUCTIONS

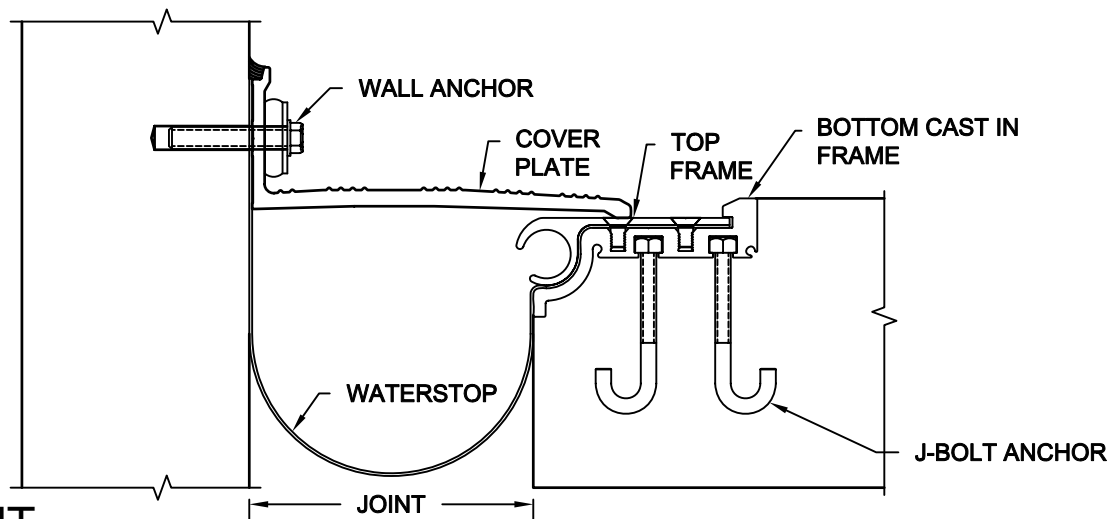
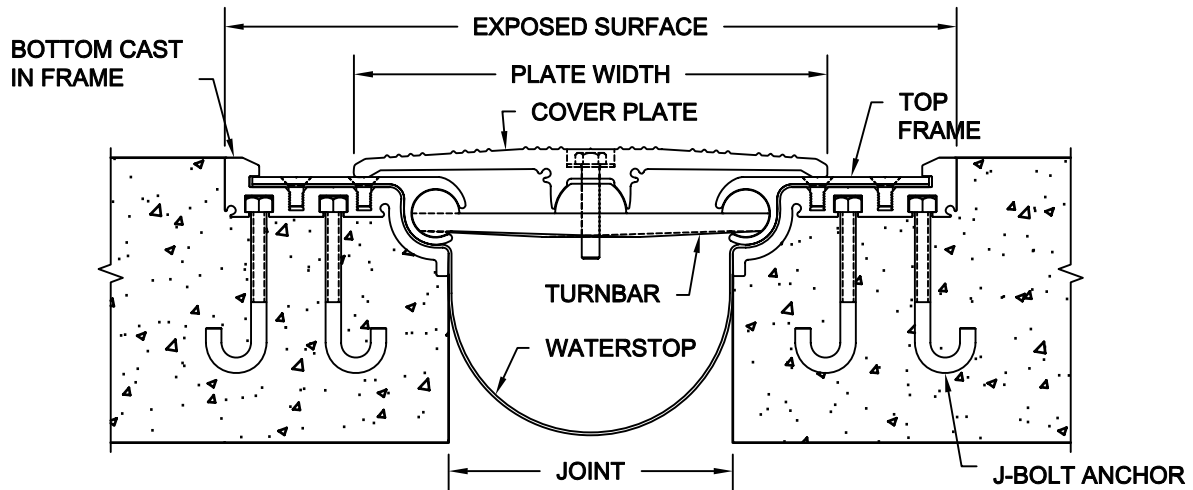

IMPORTANT INFORMATION

Prior to the commencement of Installation, all materials MUST be inspected for Damage. Any damage must be reported to CONSTRUCTION SPECIALTIES, INC., as soon as possible, so that replacement materials may be furnished without delay.

All work must be completed as per Architect's Approved "Shop Drawings", and in accordance with these Installation Instructions. When installation is complete, all materials must be protected from damage until the Architect's FINAL INSPECTION.

All materials should be arranged in the order that they are to be installed. All hardware required for each portion of the work should be placed with the appropriate materials.

Please review all Approved Shop Drawings and this Document to familiarize yourself with all the details and components of this assembly.

IMPORTANT:
READ THROUGH ALL INSTRUCTIONS PRIOR TO STARTING INSTALLATION

1/31/08

CONSTRUCTION SPECIALTIES, INC.

P.O. BOX 380
MUNCY, PA 17756
PHONE: (570)546-5941 FAX: (570)546-8022

This document is the property of Construction Specialties, Inc. and contains CONFIDENTIAL PROPRIETARY INFORMATION that is not to be disclosed to third parties and is not to be used without approval in writing from Construction Specialties, Inc.

Notes:

Before beginning installation, review the architectural drawings and approved Construction Specialties Inc. shop drawings to familiarize yourself with the joint cover models and locations.

Check all of the joint cover components to confirm that the correct joint cover model and size have been received. Also, check for materials that may have been damaged during shipping. Report all incorrect and/or damaged components to C/S at 800-233-8493.

Read through all the steps of these instructions prior to beginning work.

STEP 1

PREPARE CAST IN FRAME

STEP 1:

- 1.1) Slide J-Bolt Anchors into the nut slots on one Bottom Frame. Locate so they are 9" on center, staggered. (See Figure 1.1)
- 1.2) Apply Duct Tape (by others) to the exposed ADA compliant slope of the Base Frame for protection during concrete pouring. (See Figure 1.2)

Note: If there is only one nut slot (KBC-300/400), the J-Bolts should be located at 9" on center. J-Bolts can be positioned around post-tension tendons or pocket formers as necessary.

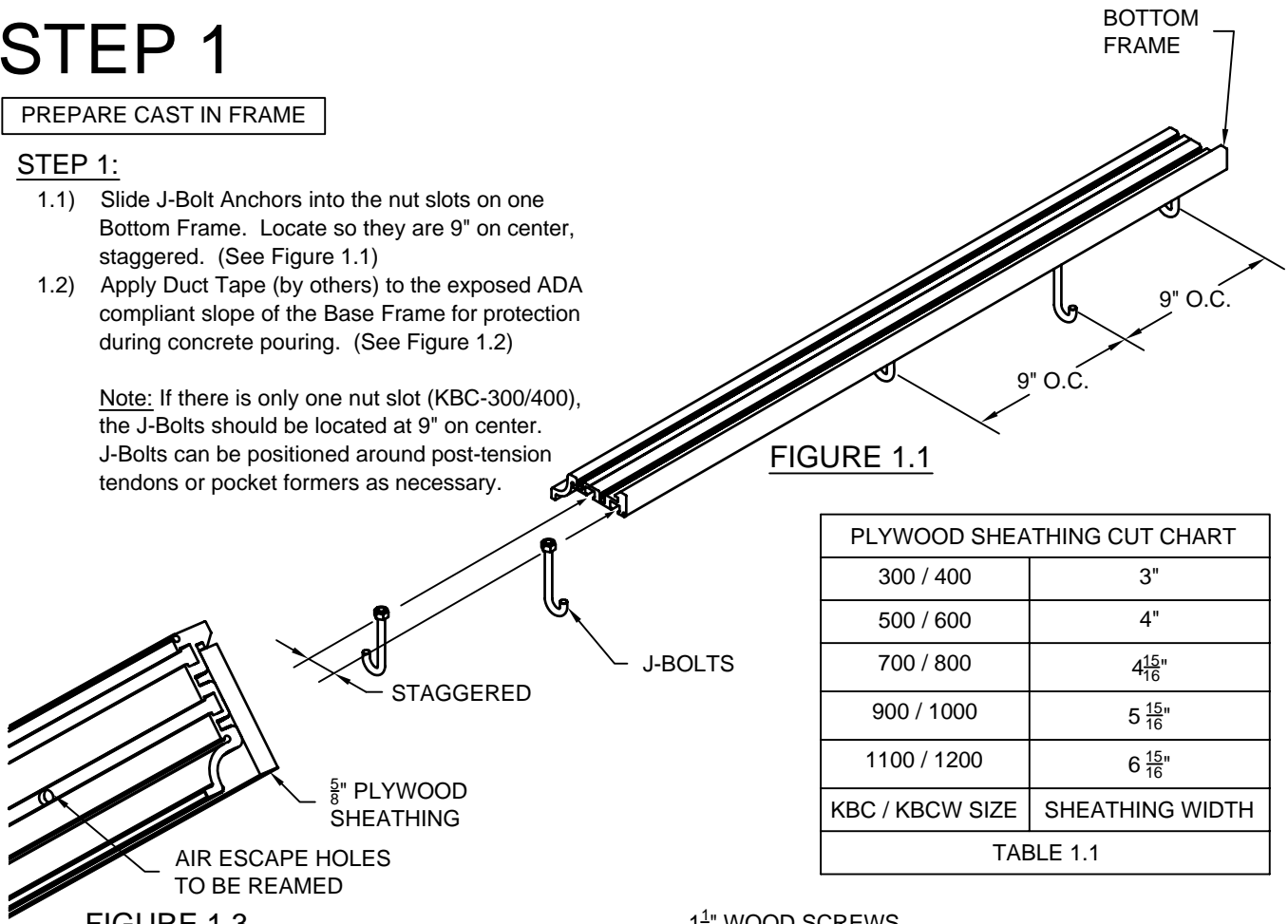

PLYWOOD SHEATHING CUT CHART	
300 / 400	3"
500 / 600	4"
700 / 800	4 ¹⁵ / ₁₆ "
900 / 1000	5 ¹⁵ / ₁₆ "
1100 / 1200	6 ¹⁵ / ₁₆ "
KBC / KBCW SIZE	SHEATHING WIDTH

TABLE 1.1

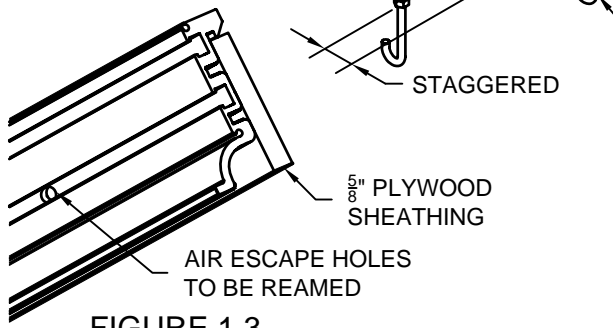

- 1.3) Next, mount $\frac{5}{8}$ " Plywood Sheathing (by others) to the Bottom Frame by first ripping the Sheathing to the proper width. (See Table 1.1)
- 1.4) Once the Sheathing is the correct width, fasten it to the Bottom Frame using $\frac{5}{16}$ "-18 x 1" Flat Head Threaded Fasteners (by others), utilizing the threaded slots in the Bottom Frame. (See Figure 1.2)
- 1.5) After the Sheathing is attached, flip the Frame Assembly over and ream the air escape holes through the Sheathing. (See Figure 1.3)
- 1.6) Finally, anchor Wood Blocks (by others) perpendicular to the Sheathing at 18" on center. (See Figure 1.2) Note: The Blocks must be long enough to extend into the open joint space to be attached to the existing slab blocking, as well as heavy enough to support the Bottom Frame during casting.

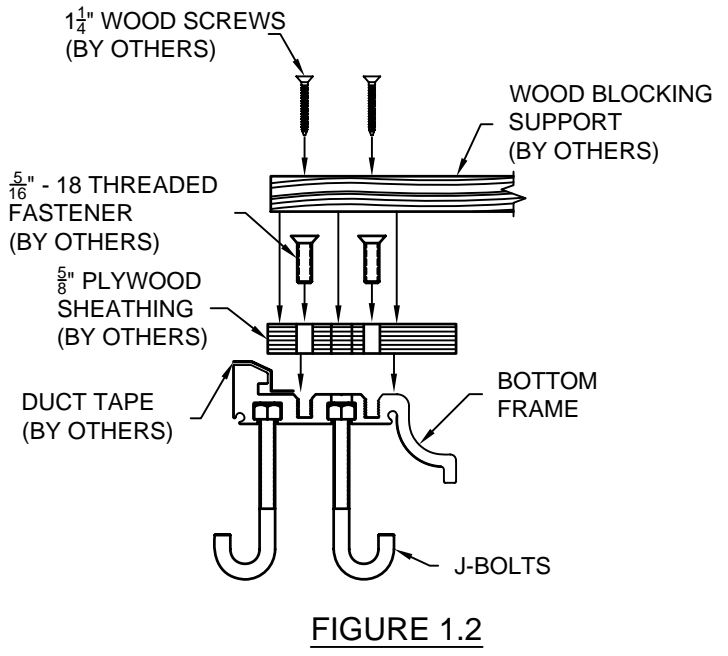

STEP 2

CAST IN FRAME INSTALLATION

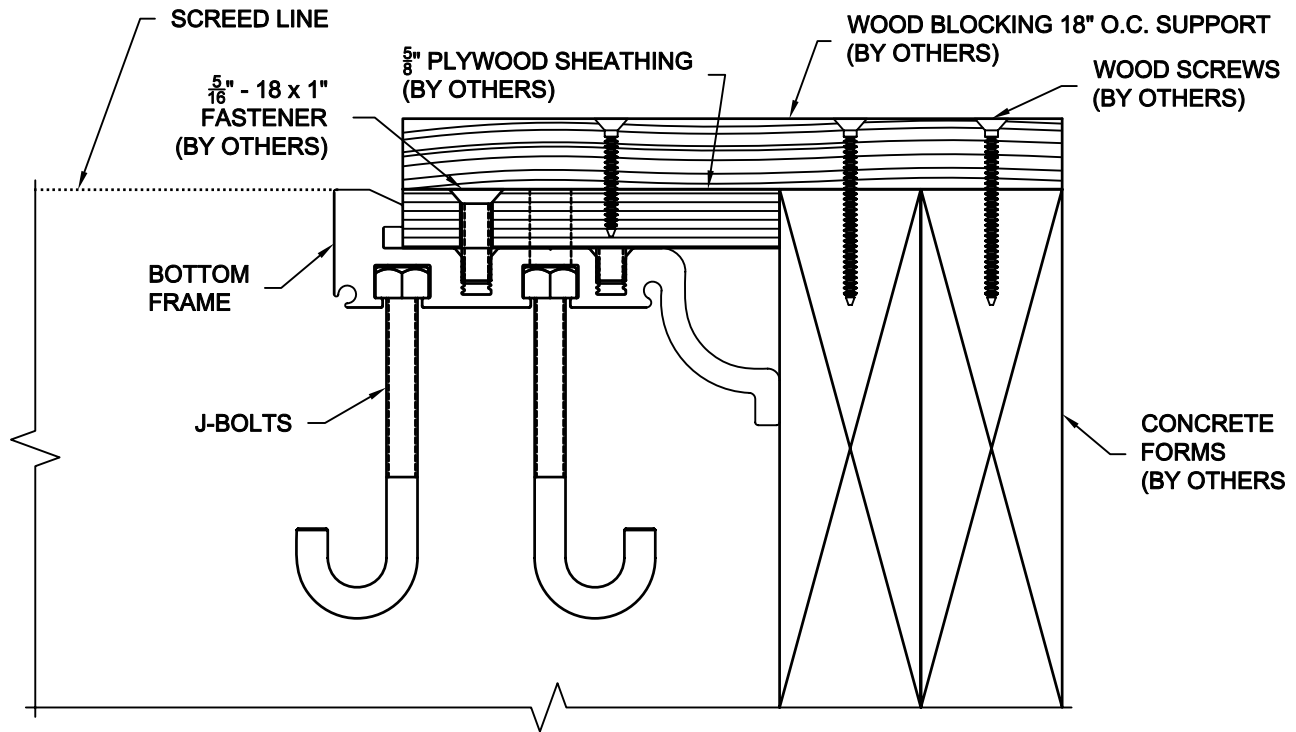

FIGURE 2.1

STEP 2:

- 2.1) Install the Bottom Frame Assembly created in Step 1 into the future slab area by setting the Wood Blocking Support on top of the Concrete Forms. After making sure the Bottom Frame leg contacts the Concrete Form, fasten the Wood Blocking Support to the Concrete Forms using Wood Screws (by others). For metal forms, drill and fasten the Wood Blocking Support with a Self Threading Fastener (by others).

STEP 3

ALIGNMENT PIN INSTALLATION

STEP 3:

- 3.1) Follow Steps 1.1 through 1.6 to prepare the next section of Bottom Frame.
- 3.2) Before installing the adjacent section of Bottom Frame, locate 2 - $\frac{3}{16}$ " x 2" steel Alignment Pins, apply an instant adhesive (by others) to half of the Alignment Pin and slide that half of the Pin into the previous section of Bottom Frame. Allow the adhesive time to set up prior to installing the next run of Bottom Frame.
- 3.3) Apply a small bead of Sikaflex 1A sealant along the edge of the Bottom Frame. **Note:** This sealant will prevent water leakage between the Frames.
- 3.4) Position the Bottom Frame Assembly so that the Alignment Pins can insert into the corresponding bosses of the adjacent Bottom Frame and butt the Frame Assemblies together. (See Figure 3.1)
- 3.5) Follow Step 2 to secure the Bottom Frame Assembly to the Concrete Forms.
- 3.6) Repeat Steps 3.1 through 3.5 for the remaining length of the run. Cut the Bottom Frames to the appropriate length where required.

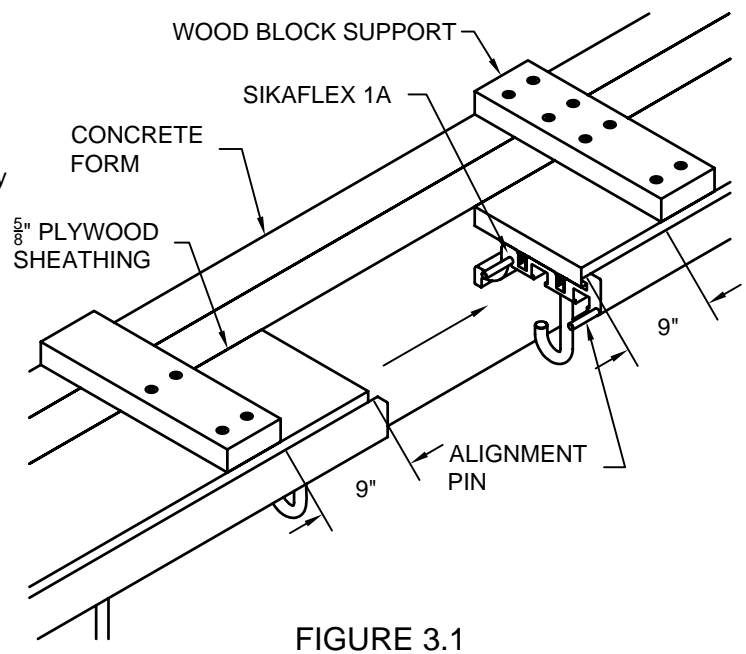

FIGURE 3.1

STEP 4

POUR CONCRETE

STEP 4:

- 4.1) After all sections of the Bottom Frame have been installed, the concrete (by others) can now be poured into the slab. Care must be taken not to shift or tilt the Bottom Frames while the concrete is being poured or leveled. It is important to make sure the concrete fills up to the base of the Bottom Frame and to the wooden form. This can be verified by checking through the air holes.

STEP 5

REMOVE SHEATHING AND BLOCKS

STEP 5:

- 5.1) Once the concrete has time for initial cure, the Wood Blocking and the $\frac{5}{8}$ " Plywood Sheathing can be removed.

Note: If installing a KBC system, Steps 1 - 5 should be repeated for the opposite side of the joint before continuing on to Step 6. If a KBCW system is being installed proceed to Step 6.

STEP 6

INSTALL WATERSTOP

STEP 6:

- 6.1) Install the Waterstop per the proper Installation Instructions and note the following:
 - The Waterstop can be held in place with Duct Tape if needed.
- 6.1) Once the Waterstop is in the joint, the Top Frame can be used as a template to puncture holes in the Waterstop at locations that require a $\frac{5}{16}$ " - 18 Flat Head Fastener. For KBCW models the Cover Plate can also be used as a template to puncture holes in the Waterstop against the wall. (See Figures 6.1 & 6.2)

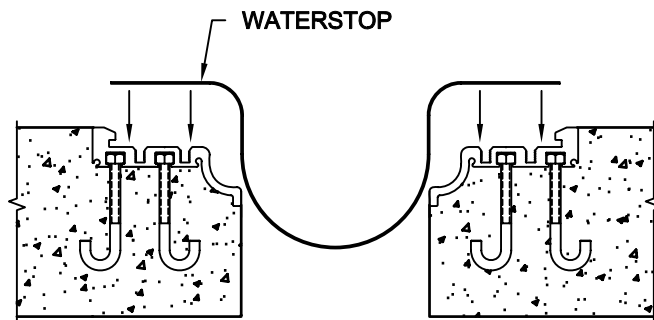

FIGURE 6.1

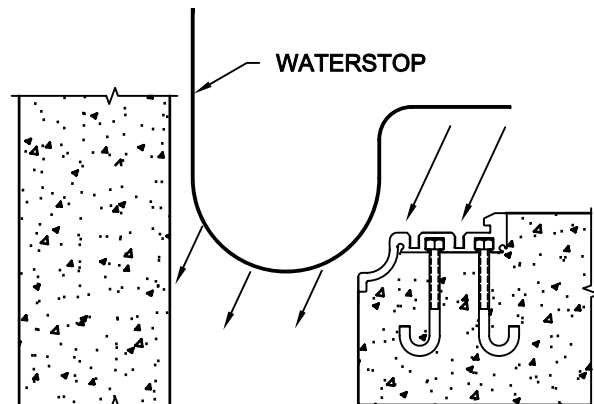

FIGURE 6.2

STEP 7

TOP FRAME INSTALLATION

STEP 7:

- 7.1) Slide the Top Frame under the notch of the Bottom Frame, and butt it against the Bottom Frame. (See Figure 7.1)
- 7.2) Once in position, fasten the Top Frame to the Bottom Frame using the C/S supplied $\frac{5}{16}$ " - 18 x $\frac{5}{8}$ " SS PFH Machine Screws. (See Figure 7.1)
Note: Be sure to keep the supplied Machine Screws as straight as possible when installing. Failure to do this could result in cross-threading, which will impair the system.
- 7.3) If installing a KBC system repeat Steps 7.1 and 7.2 for the opposite side of the joint.
- 7.4) If installing a KBCW system proceed to Step 11.

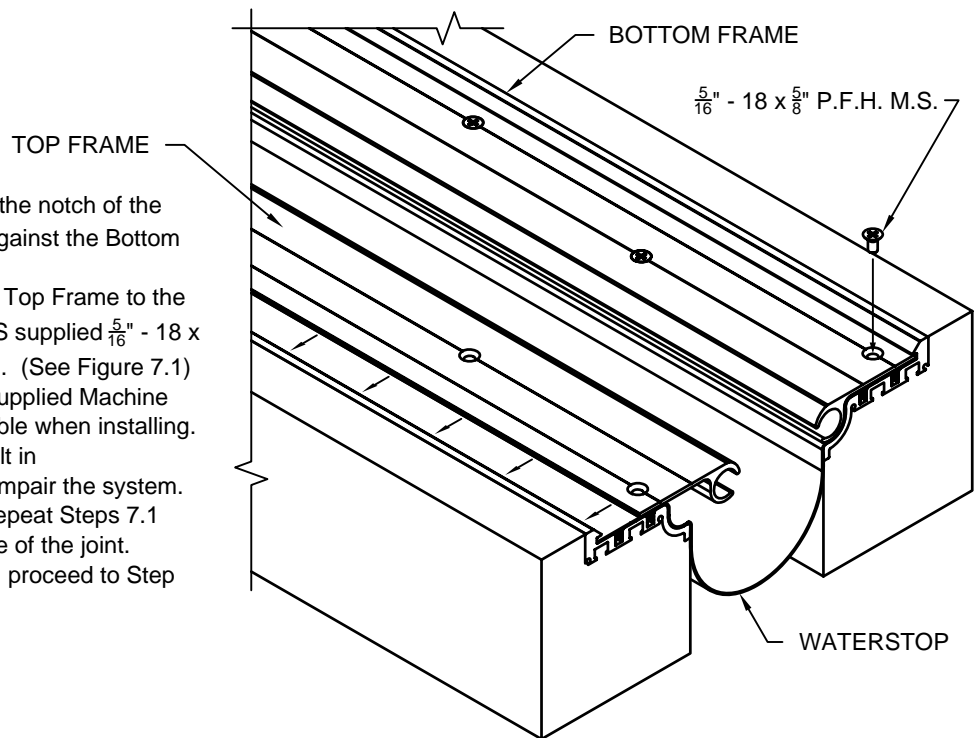

FIGURE 7.1

STEP 8

KBC TURNBAR INSTALLATION

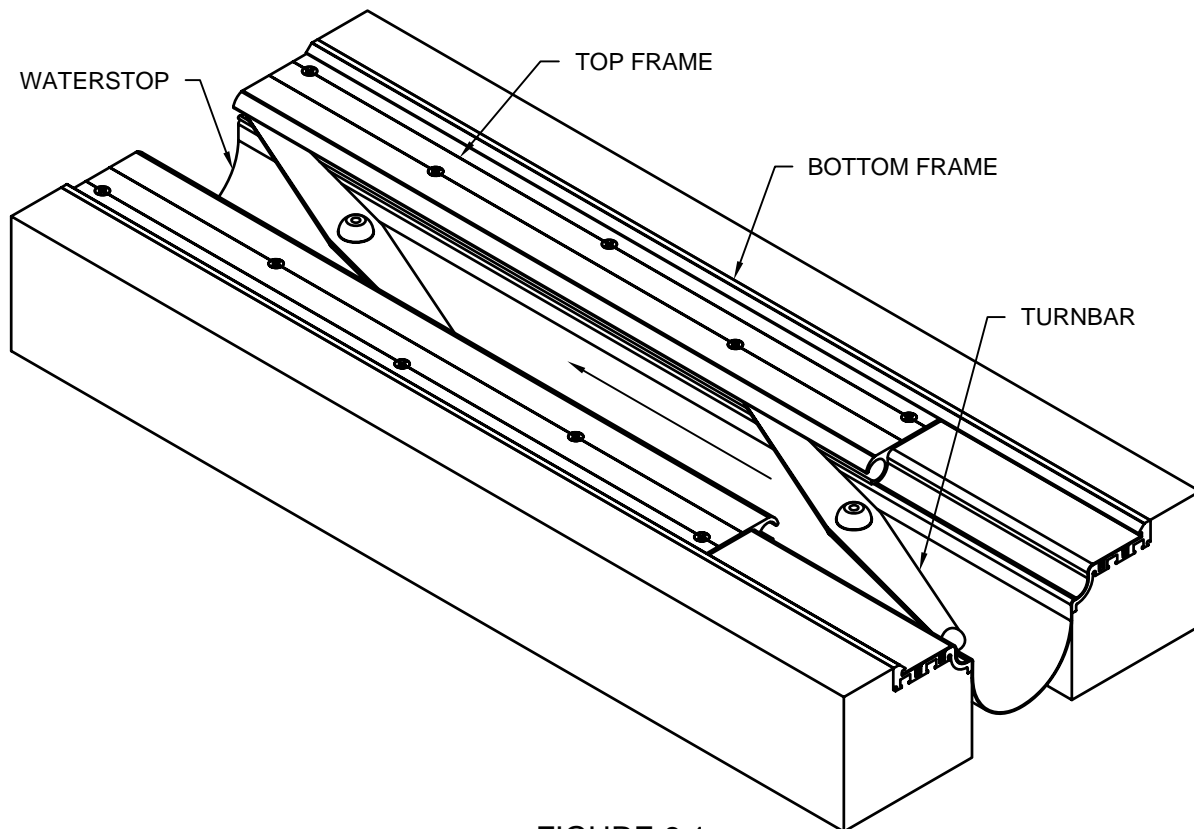

FIGURE 8.1

STEP 8:

- 8.1) After installing two parallel sections of Top Frame, slide in the required amount of Turnbars locating them 18" on center. (See Figure 8.1)
- 8.2) Once all Turnbars for that section are installed, repeat Step 7 for the next section of Top Frame.
- 8.3) Repeat Steps 8.1 and 8.2 until you reach the last section of Top Frame. **Note:** Prior to installing the last section of Top Frame read Step 9 and slide enough Turnbars into the previous section of Top Frame.
- 8.4) Install the last sections of Top Frame. Slide the correct number of Turnbars into the Top Frame for the last section.

STEP 9

INSTALL END PLATES

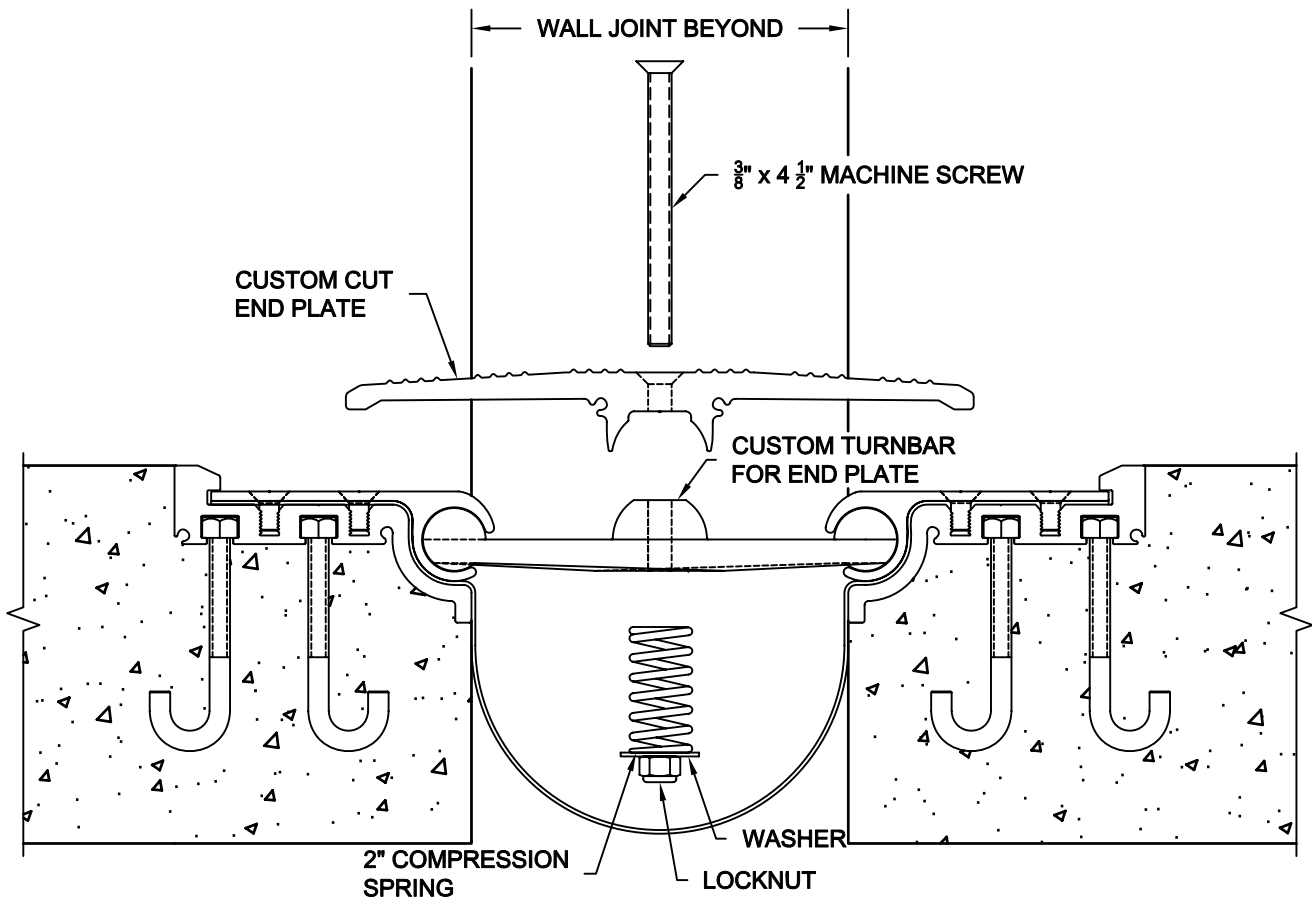

STEP 9:

Note: Prior to installing Cover Plates, clean all Top Frame Turnbar receivers of any debris. Debris could impair the function of the system and possibly cause permanent damage.

Note: End Plates are required at each end of each run of joint cover and also adjacent to deck to wall/column conditions to allow for lateral movement of the joints during a seismic event. Place the End Plates where indicated on the approved C/S shop drawings. End Plates for KBC 300 - 600 are 12" long, 18" long for KBC 700 - 1000 covers, and 24" long for KBC 1100 - 1200. End Plates require Custom Turnbars with a clearance hole in the center instead of the usual threaded hole.

- 9.1) Position the center of the End Plate Turnbar approximately 6" in from the face of the wall (9" at 6" - 10" joints and 12" at 11" - 12" joints).
- 9.2) Position the custom cut End Plate so that it is centered over the joint with the square cut end of the Plate against the wall or column.
- 9.3) Working down through the bolt hole in the center of the End Plate, align the center hole of the Custom Turnbar with the hole in the End Plate. Note: The semi-sphere in the Turnbar should be seated in the semicircular recess on the bottom of the End Plate.
- 9.4) Place a C/S supplied 4 1/2" Flat Head Machine Screw in the countersunk hole in the End Plate and through the reamed clearance hole in the Custom Turnbar. Note: For 9" - 12" joint sizes the C/S supplied flat head machine screw will be 5" long.
- 9.5) From the underside of the Plate, place a 2" compression spring on the bolt below the Turnbar. Place a flat washer and lock nut on the end of the bolt to retain the spring. Tighten the nut until the spring has been compressed approximately 1/4".

STEP 10

INSTALL COMMON COVER PLATES

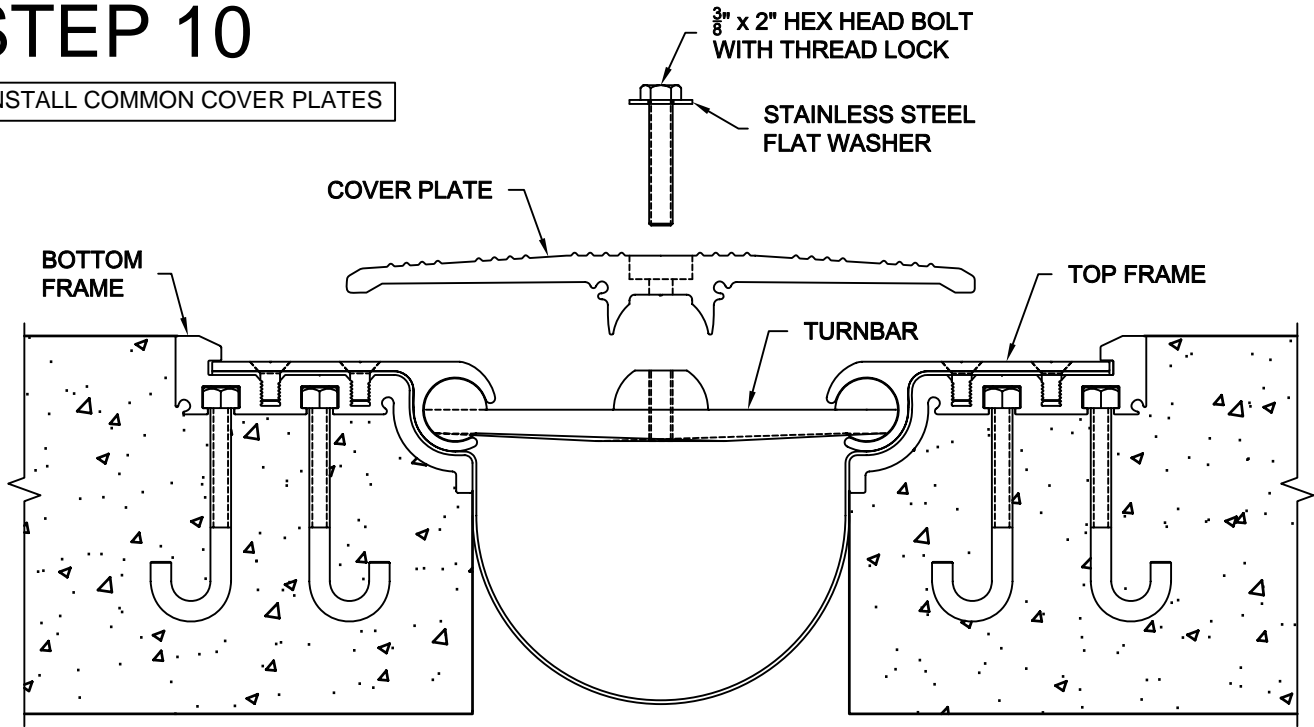

FIGURE 10.1

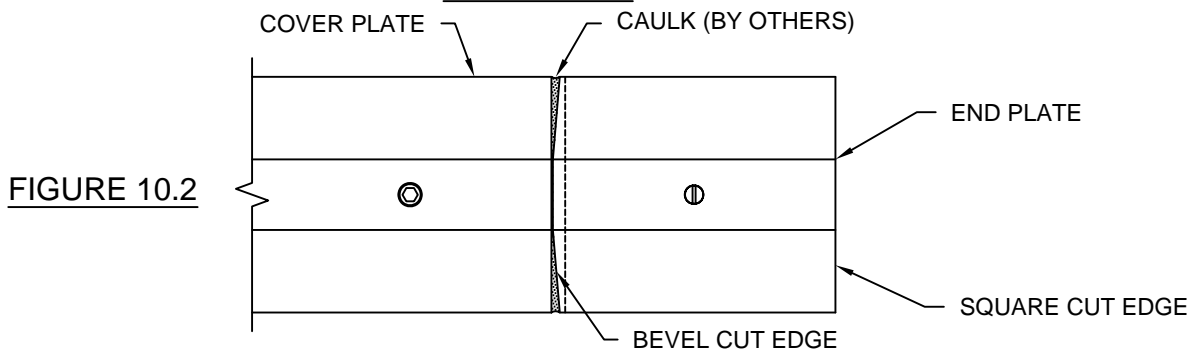

FIGURE 10.2

STEP 10:

Note: The Cover Plates have been supplied in 10'-0" or 20'-0" lengths. Some Plates may have to be cut to length to suit the specific length of a run. When cutting Plates, a minimum of (2) Turnbar holes must be maintained for the Plate to function properly during seismic movement. (Excluding the End Plate previously installed.)

- 10.1) Beginning at the end of the run adjacent to the End Plate, place the first length of Cover Plate on the concrete deck, parallel to the joint. Align the end of the Plate with the beveled end of the End Plate.
- 10.2) Slide the Turnbars so that the center hole of each Turnbar is aligned with each center bolt hole in the Cover Plate.
- 10.3) Position the Cover Plate over the joint with the Plate resting on the Top Frames and the semi-sphere portion of the Turnbars positioned in the recessed area on the bottom of the Cover Plate.
- 10.4) Working through the center bolt holes of the Cover Plate with a screwdriver or drift pin, align the center holes of each Turnbar with the hole in the Cover Plate.
- 10.5) Place a S/S Flat Washer on each 2" Hex Head Bolt (C/S supplied), insert a bolt through each hole and partially thread into each Turnbar. **Note:** Do not tighten until all of the bolts have been started as some adjustments may be required.
- 10.6) With all the center bolts for this length of Plate in place, tighten the bolts by hand and torque to 40 ft. lbs. **Note:** Over torquing the bolts may cause damage to the system.
- 10.7) Continue with installation of adjacent Plates. Use Alignment Pins, placed in the bosses on the underside of the Plate, to maintain alignment of the Plate edges.

Note: Due to the bevel cut on the lead edge of the End Plate, there will be a tapered gap between the End Plate and the adjacent Plate. This gap should be filled with a silicone caulk by others. (See Figure 10.2)

THIS COMPLETES THE INSTALLATION OF A "KBC" SYSTEM.

STEP 11

INSTALL "KBCW" COVER PLATES

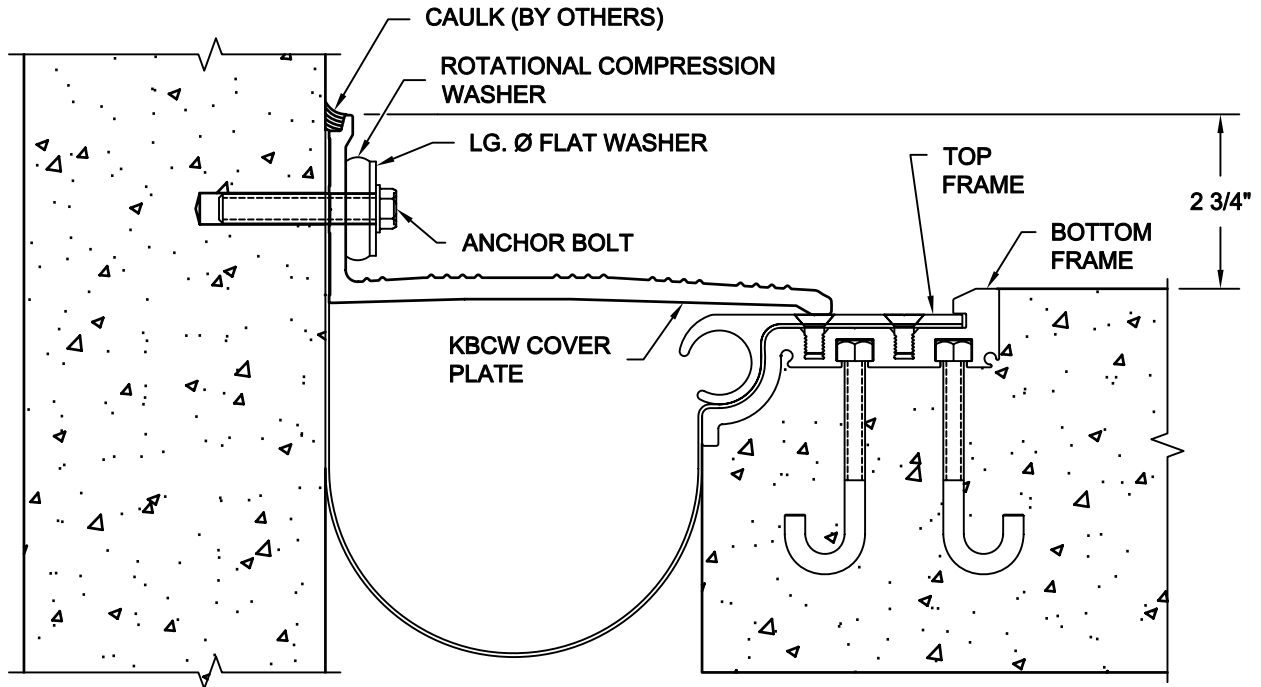

STEP 11:

Note: The Cover Plates have been supplied in 10'-0" or 20'-0" lengths. Some Plates may have to be cut to length to suit the specific length of a run.

- 11.1) Install the Bottom Frames, Top Frames, and Waterstop per Steps 1 - 7 of this installation instruction before continuing to the following steps.
- 11.2) If required, cut a section of "KBCW" Cover Plate to the length needed for the run.
- 11.3) Position the Cover Plate on top of the Top Frame and against the face of the wall or column. Using the Cover Plate as a template, drill the holes for the C/S supplied Anchor Bolts.
- 11.4) Place a Large Diameter Flat Washer and a Rotational Compression Washer (rubber) onto each Anchor Bolt, and anchor the Cover Plate to the wall or column.
- 11.5) Apply silicone caulk (by others) along the top edge of the Cover Plate.

THIS COMPLETES THE INSTALLATION OF A "KBCW" SYSTEM.