

# MODEL RJ-27LP AND RJ-28LP ROOF JOINT COVER INSTALLATION INSTRUCTIONS

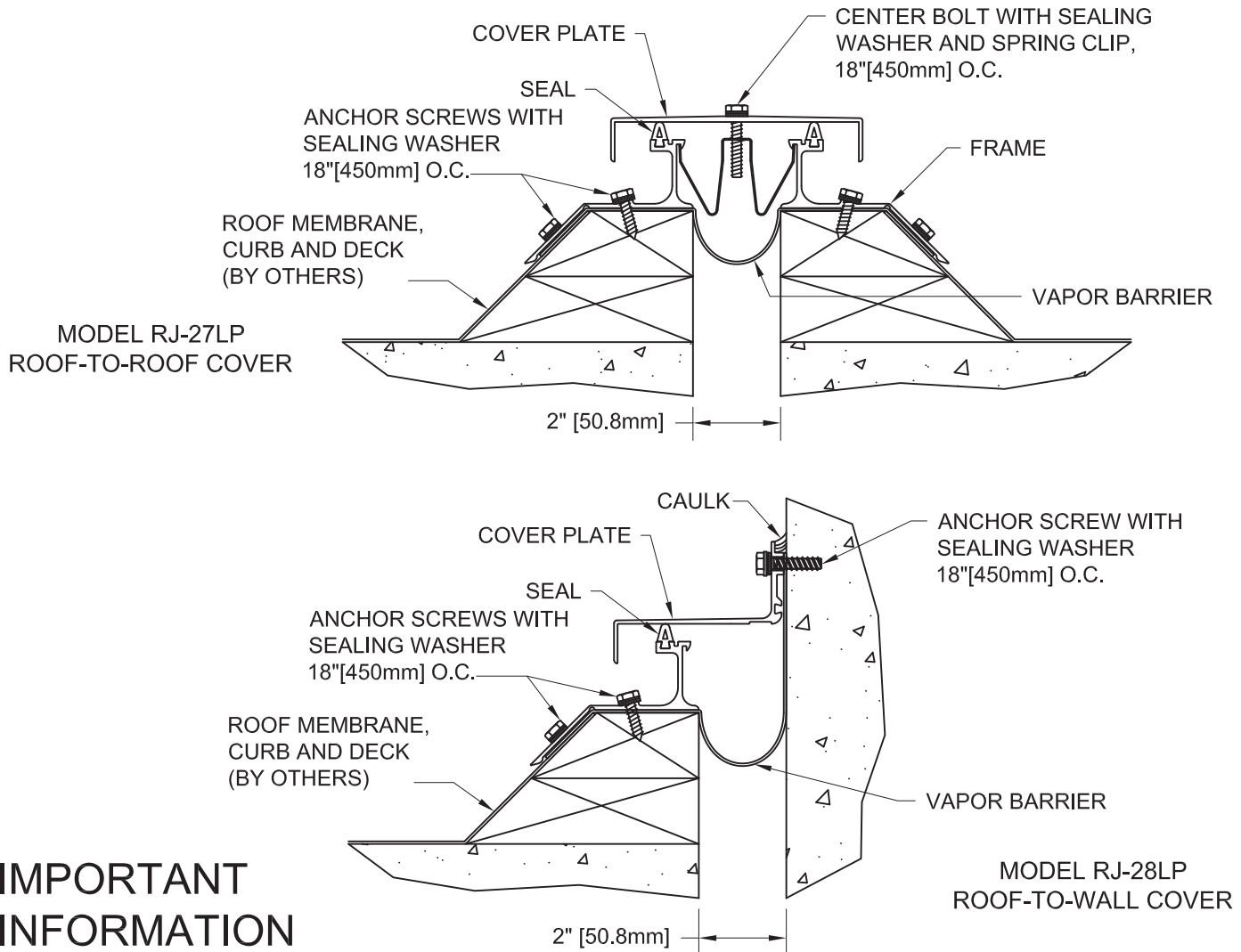

## IMPORTANT INFORMATION

Prior to the commencement of installation, all materials MUST be inspected for damage. Any damage must be reported to CONSTRUCTION SPECIALTIES, INC., as soon as possible, so that replacement materials may be furnished without delay.

All work must be completed as per Architect's Approved "Shop Drawings", and in accordance with these Installation Instructions. When installation is complete, all materials must be protected from damage until the Architect's FINAL INSPECTION.

All materials should be arranged in the order that they are to be installed. All hardware required for each portion of the work should be placed with the appropriate materials.

Please review all Approved Shop Drawings and this document to familiarize yourself with all the details and components of this assembly.

**IMPORTANT:**  
READ THROUGH ALL INSTRUCTIONS PRIOR TO STARTING INSTALLATION

10/19/09



**Construction Specialties™**

6696 Route 405 Highway, Muncy PA 17756  
(800) 233-8493 . Fax (570) 546-5169 . www.c-sgroup.com

This document is the property of Construction Specialties, Inc. and contains CONFIDENTIAL PROPRIETARY INFORMATION that is not to be disclosed to third parties and is not to be used without approval in writing from Construction Specialties, Inc.

# GENERAL NOTES

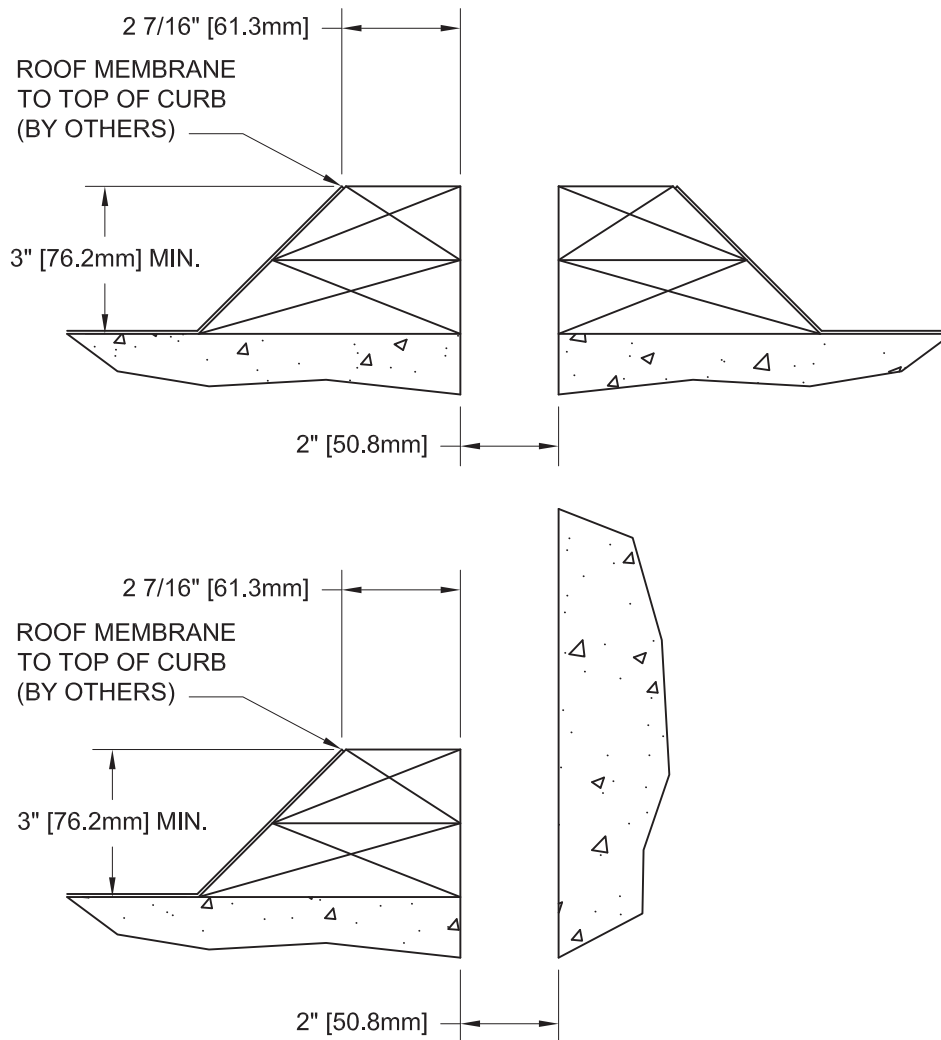

1.) The level of water protection provided by the roof joint covers is highly dependent upon proper installation. Read through all of these instructions and review the architectural drawings and approved C/S shop drawings prior to beginning installation.

2.) These installation instructions indicate a common roof curb construction. Other configurations of roof curb and roof deck construction can be accommodated. Refer to the C/S shop drawings for details of alternate construction. Note: The dimension at the top of the curb must be 2 7/16"[61.3mm] (to the outside of the roof membranes) to allow for proper fit and spacing of the roof cover frames.

3.) A given run of roof joint cover may require more than one length of roof cover, the roof cover may turn corners, and/or the configuration of roof cover may change from roof-to-roof to roof-to-wall along the run. If so, factory supplied splice plates and transition components must be installed. Please refer to the C/S shop drawings for details of these conditions. General installation details for these conditions are included in these instructions.

4.) These instructions provide procedures that will help to maximize the water/weather protection provided by the completed installation. Additional steps or variations to some steps may be made as long as the integrity of the installation is maintained.

5.) Before beginning installation, check the field conditions against the architectural drawings and the C/S shop drawings to assure that the roof joint, curb, roof membrane(s) and deck have been prepared as detailed to allow for proper fit and function of the joint cover systems.

6.) When installing adjacent lengths of aluminum extrusion, always leave a 1/16"[1.6mm] minimum gap between pieces for thermal expansion. These gaps may be filled with sealant (by others) as instructed.

# STEP 1

## INSTALL VAPOR BARRIER

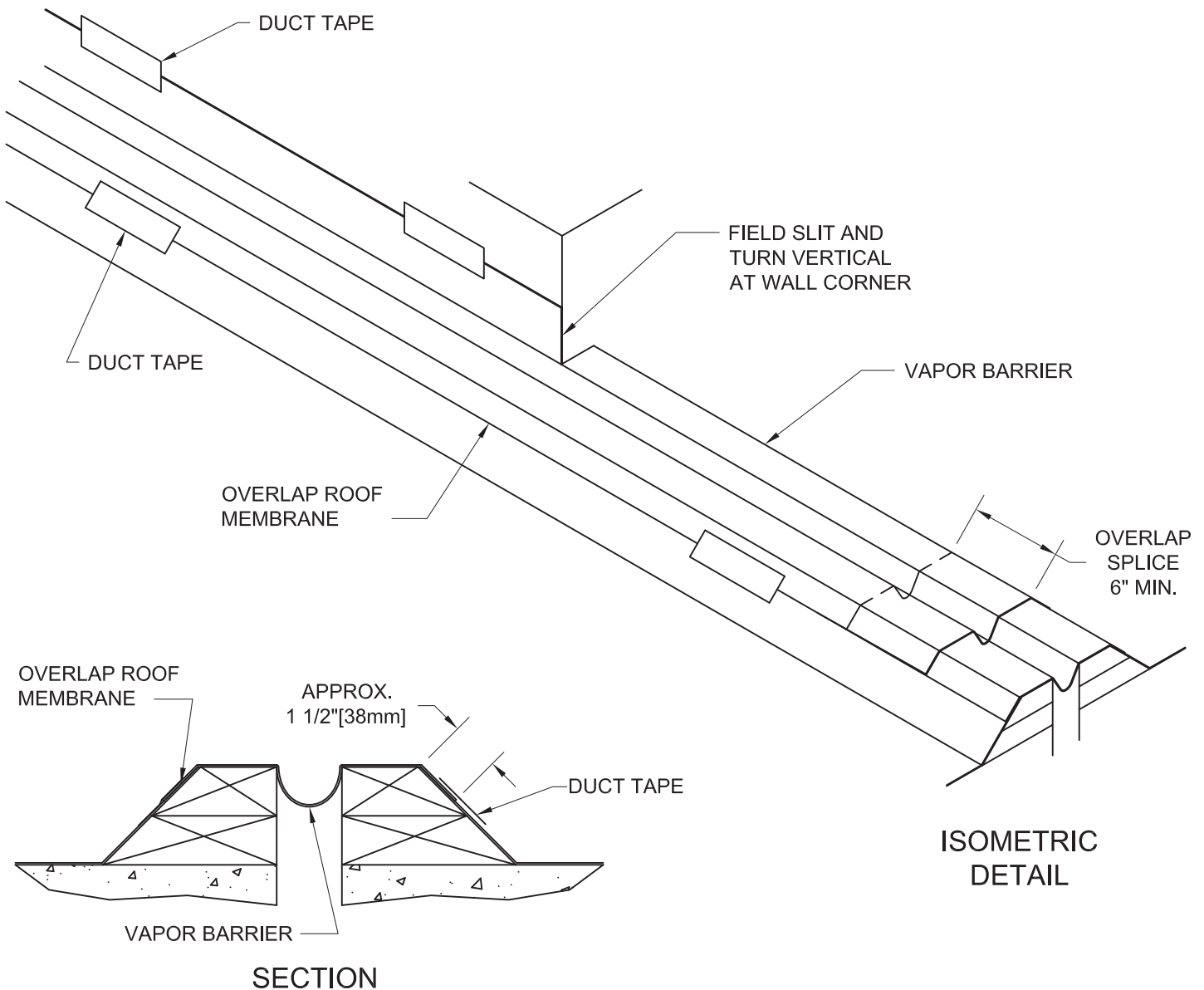

**Note:** The Vapor Barrier for the RJ-27 and RJ-28 roof joint covers is polyethylene sheet, supplied in rolls at the required 12"[304.8mm] width.

1.1) Unroll a length of Vapor Barrier along the side of the joint and cut to length as needed. If additional length is needed, refer to the field splicing instructions on page 4. **Note:** At end conditions and/or corners (see C/S shop drawings), allow extra length of Waterstop as needed to transition to exterior wall joint covers or to create transitions around any corners.

1.2) Place the Vapor Barrier over the joint and drape the center of the Vapor Barrier slightly down into the joint. The proper drape will be created as the edges are positioned as indicated below.

1.3) At roof-to-roof applications, each edge of the Vapor Barrier is to extend down the sloped face of the curb by approx. 1 1/2". The edge of the Vapor Barrier will overlap the roof membrane. At roof-to-wall applications, the roof side edge will extend down the curb as described and the wall side edge will extend up the wall to approx. 3 3/4" above the top of the curb.

1.4) Use short lengths of duct tape to hold the Vapor Barrier in position until it is anchored.

# STEP 1 Cont...

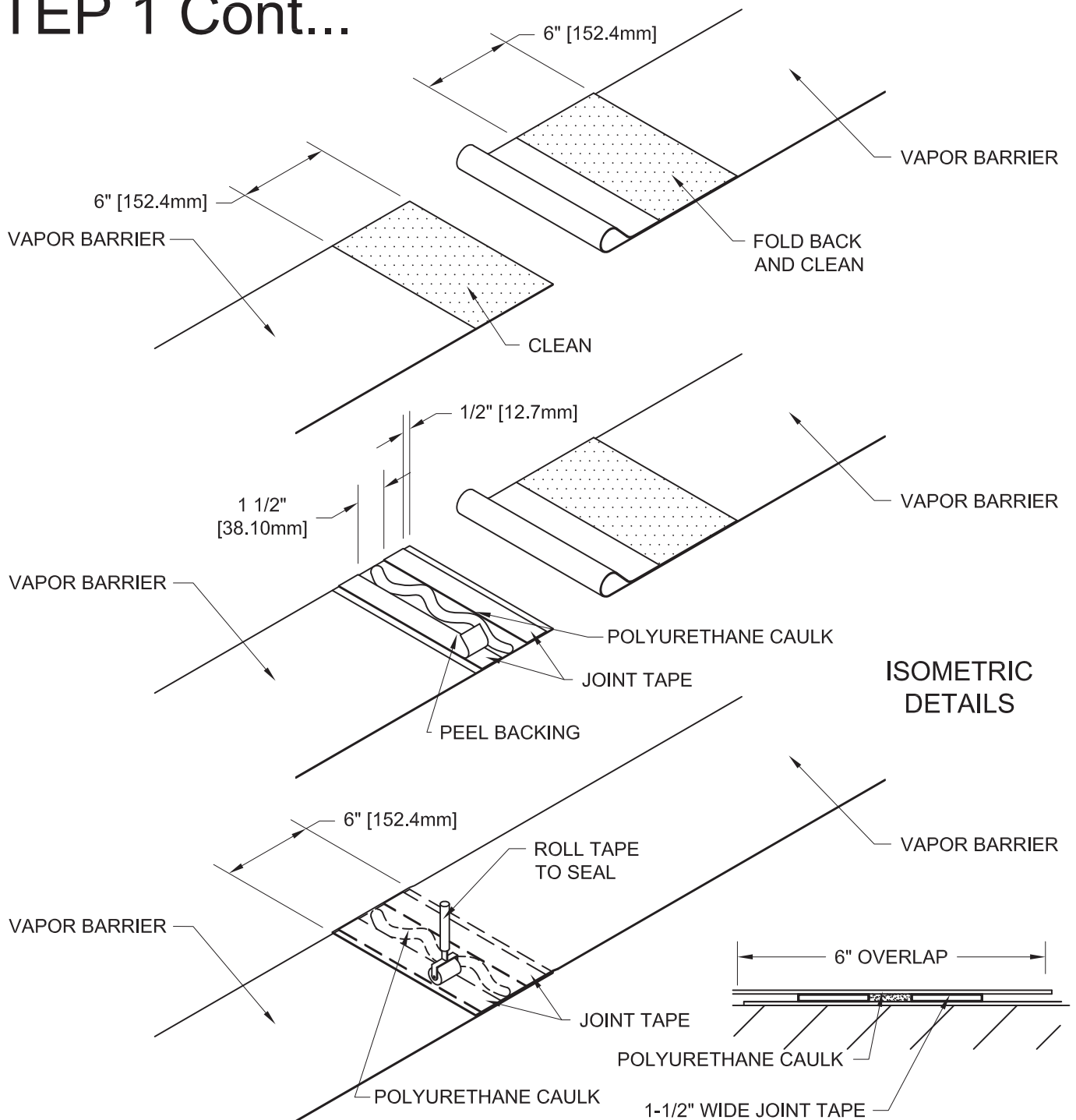

- 1.5) Unroll an additional length of Vapor Barrier along the side of the joint and cut to length.
- 1.6) Fold back the end of the additional length of Vapor Barrier to expose the bottom surface and clean the last 6" [152.4mm] of each piece with Denatured Alcohol.
- 1.7) Apply (2) pieces of the C/S supplied Joint Tape to the end of the first length of Vapor Barrier, at approx. the spacing indicated in details above. **DO NOT REMOVE PAPER BACKING FROM TAPE.**
- 1.8) Apply a 1/4" continuous bead of the C/S supplied polyurethane caulk between the Tape. Remove the paper backing from Tape.
- 1.9) Fold the second length of Vapor Barrier back and overlap the first length by approx. 6" [152.4mm] and align the outside edges.
- 1.10) Avoid wrinkles and seat the second piece of Vapor Barrier onto the strips of Joint Tape. Use a seam roller or other round object to roll the Joint Tape to remove air pockets and to fully seal the splice area.

# STEP 2

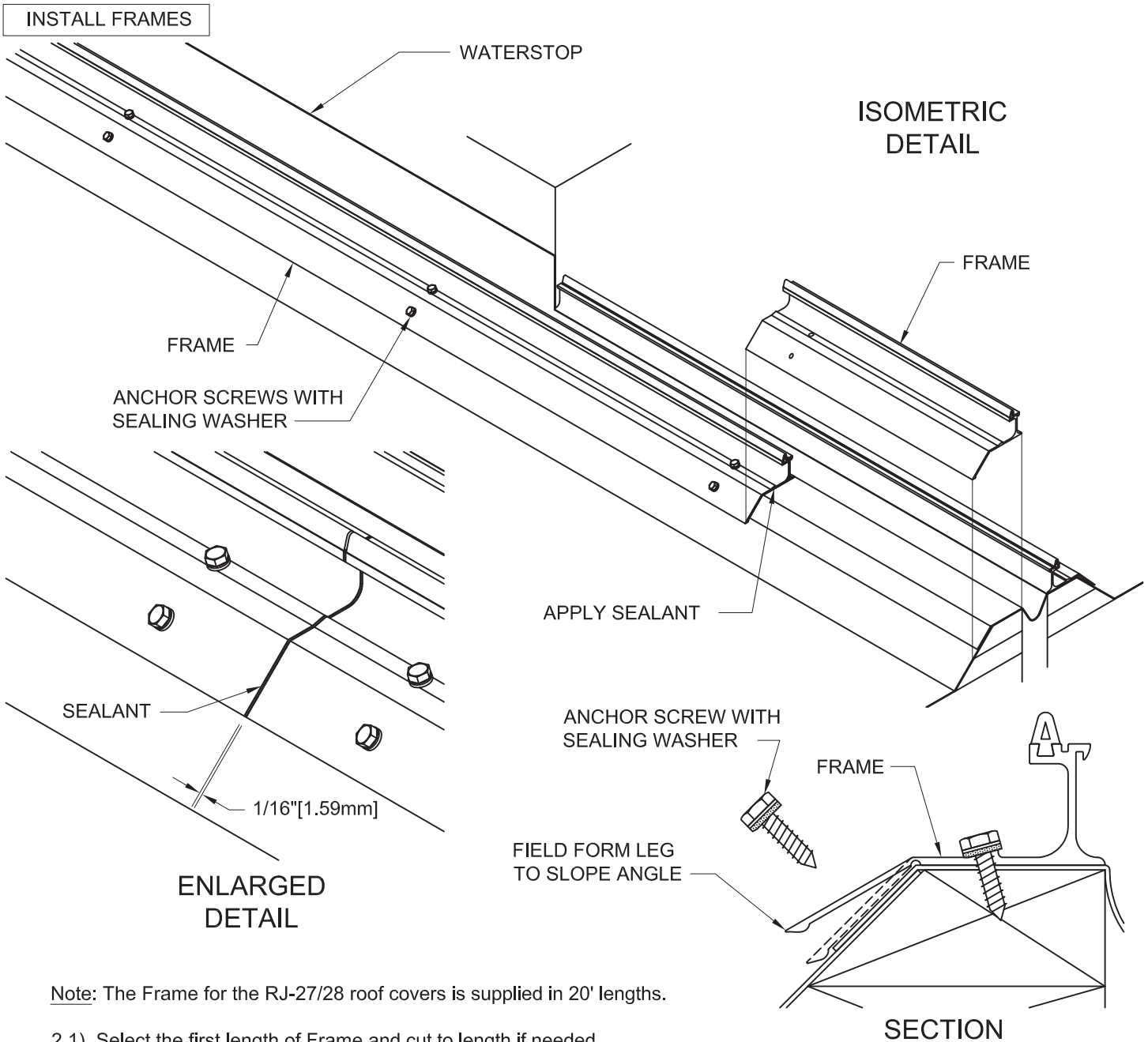

Note: The Frame for the RJ-27/28 roof covers is supplied in 20' lengths.

2.1) Select the first length of Frame and cut to length if needed.

2.2) Position the Frame on the top of the curb with the inside edge of the Frame aligned with the joint edge. Install the C/S supplied anchor screws (with sealing washers) in the line of anchor holes nearest to the joint.

2.3) The leg of the Frame that extends down the slope of the curb is to be field formed to match the slope angle of the curb and to fit tightly to the Waterstop and roof membrane. Bend the leg downward by hand and install the lower row of anchor screws.

Note: The last anchor, near the end of the Frame, is to be no more than 6" [150mm] in from the end. If after cutting the Frame to length the end hole is more than 6" [150mm] in from the end, drill a new hole (using a 9/32" [7mm] bit) at 4" [150mm] in from the end of the Frame and install an anchor.

Note: If additional lengths of Frame are required, create a field Frame Splice as follows:

2.4) Apply sealant (by others) to the end face of the installed length of Frame.

2.5) Position the next length of Frame into the sealant but maintain a 1/16" [1.6mm] gap between Frames. Anchor the Frame to the curb as instructed above.

Install all Frames required for the run.

PAGE 5

# STEP 2 CONT.

## INSTALL FRAMES

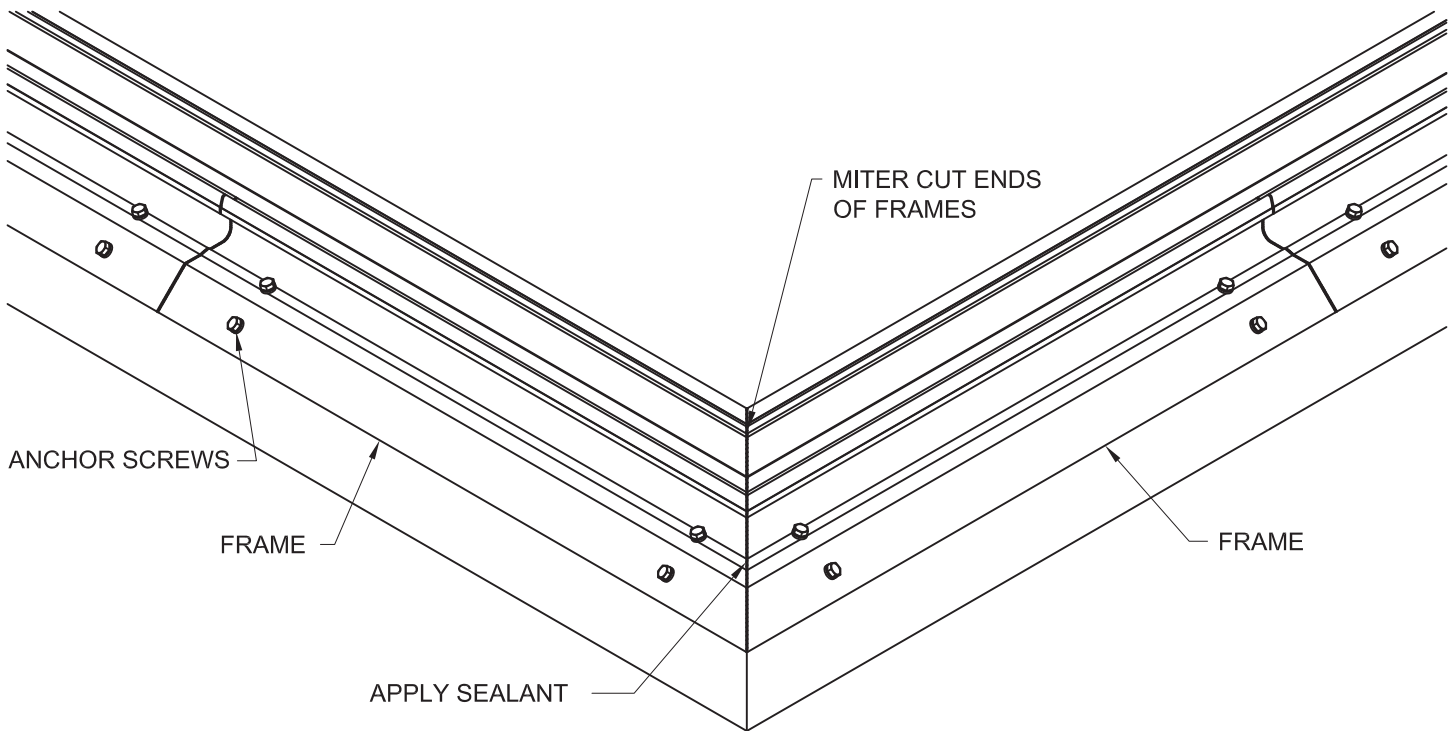

ISOMETRIC DETAIL  
AT 90° CORNER

Note: Both the RJ-27 and RJ-28 roof covers may be required to turn corners in the course of a given run. The instructions below describe installation of the Frames, using a 90° roof-to-roof corner as an example.

- 2.6) Measure the length of Frame needed to extend to the corner of the curb.
- 2.7) Miter cut the end of each piece of Frame at the angle needed to create the proper miter.
- 2.8) Position the first piece of Frame and anchor to the curb as instructed. Drill and add new anchor holes as needed.
- 2.9) Apply sealant (by others) to the end face of the installed length of Frame.
- 2.10) Position the next length of Frame (with the opposite miter cut) into the sealant but maintain a 1/16"[1.6mm] gap between Frames. Anchor the Frame to the curb as instructed above.

# STEP 3

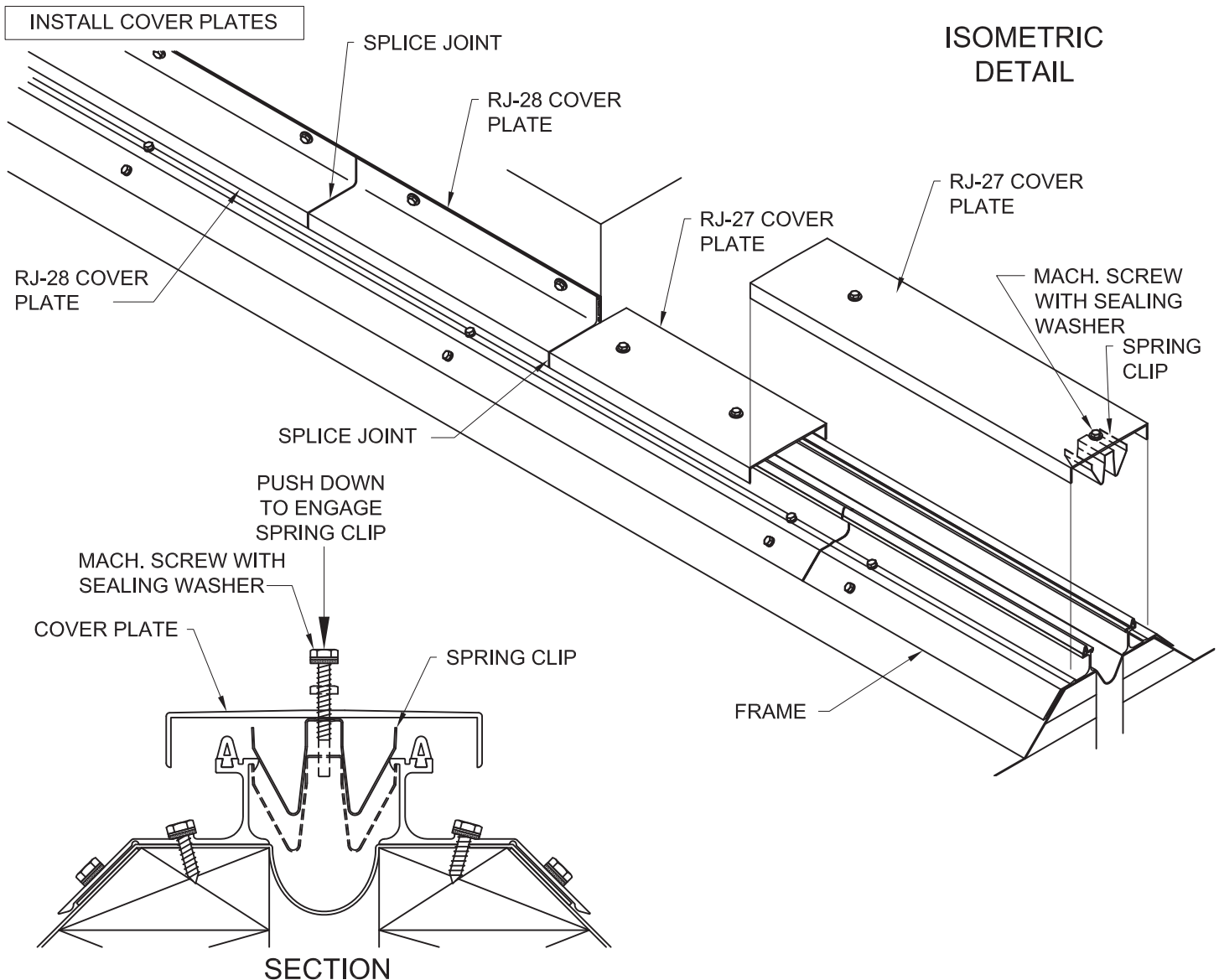

**Note:** The RJ-27/28 Cover Plates are supplied in 20' lengths. Installation of the Cover Plates must be coordinated with installation of factory fabricated Corner Miters and Transition Pieces as indicated on the C/S shop drawings. Install and/or position the factory fabricated components first (refer to Step 4, page 8) and cut the Cover Plates to fit the required dimension between these components. Always leave a 1/16"[1.6mm] minimum gap between adjacent pieces of Cover Plate for thermal expansion.

For RJ-27 Roof-to-Roof Cover Plates:

3.1) Establish the required length for the first piece of Cover Plate and cut the piece to length if needed.

3.2) Pre-attach the Spring Clips to the Cover Plate by placing a C/S supplied 1/4-20 machine screw (with sealing washer) through each hole in the Cover Plate. On the underside of the Cover Plate, thread a Spring Clip onto each screw. **Note:** The Spring Clips are to only be threaded onto the screws approx. 1/4" to allow for installation. **Note:** A Spring Clip must be no more than 6"[150mm] in from each end of the Cover Plate. If after cutting the Cover Plate to length the end hole is beyond 6"[150mm], drill a new hole (using a 9/32"[7mm] bit) at 4"[100mm] in from the end of the Cover Plate, and install a Spring Clip (minimum of (2) Spring Clips per length).

3.3) Position The Cover Plate over the Frames and rotate each Spring Clip to the proper orientation as indicated. The Spring Clips will rest on top of the Frames with the machine screws protruding above the top of the Cover Plate. With the Cover Plate in position, press down on each machine screw forcing the Spring Clip down until it snaps into position in the frames. (**Note:** If possible, look under the Cover Plate from the end of the run to see if each Spring Clip is properly engaged in the Frames.) Tighten each machine screw until it is snug.

**Note:** If an additional length or lengths of Cover Plate are required for the run, prepare and install the Cover Plates as instructed above. Maintain a 1/16"[1.6mm] minimum splice joint between lengths.

Cover Plate installation continued next page.

PAGE 7

# STEP 3 CONT.

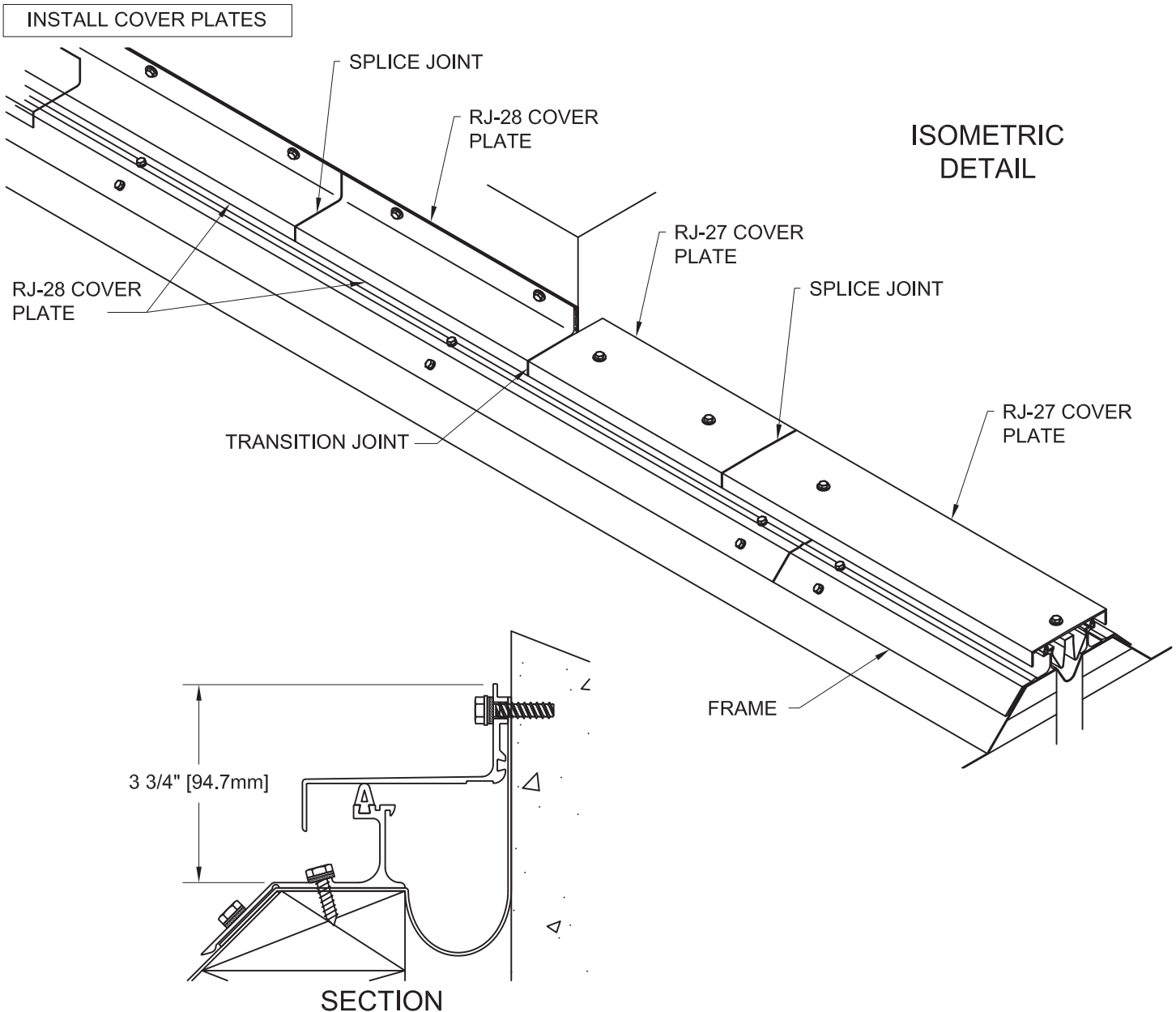

## RJ-28 Roof-to-Wall Cover Plates:

3.4) Establish the required length for the first piece of Cover Plate and cut the piece to length if needed. Note: The last anchor near the end of the Cover Plate is to be no more than 6"[150mm] in from the end. If, after cutting the Cover Plate to length, the end hole is beyond 6"[150mm] from the end, drill a new hole (using a 9/32"[7mm] bit) at 4"[100mm] in from the end of the Cover Plate.

3.5) On the wall opposite the Frame, strike a level chalk line on the face of the wall to locate the anchor position for the top edge of the RJ-28 Cover Plate. The line is to be placed at 3 3/4"[94.7mm] above the base of the Frame as indicated above.

3.6) Position the Cover Plate over the Frame and against the wall. Using the holes in the Cover Plate as a template, mark the locations for the wall anchor screws and remove the Cover Plate.

3.7) Drill the holes for the C/S supplied anchor screws as required using the appropriate drill bit. Then clean the holes as needed.

3.8) Reposition the Cover Plate on the Frame and against the wall and anchor in position.

Note: If an additional length or lengths of Cover Plate are required for the run, prepare and install the Cover Plates as instructed above. Maintain a 1/16"[1.6mm] minimum splice joint between lengths. For the transition from RJ-27 Cover Plate to RJ-28 Cover Plate maintain a 1/16"[1.6mm] minimum gap between plates.

# STEP 4

## INSTALL CORNER MITER

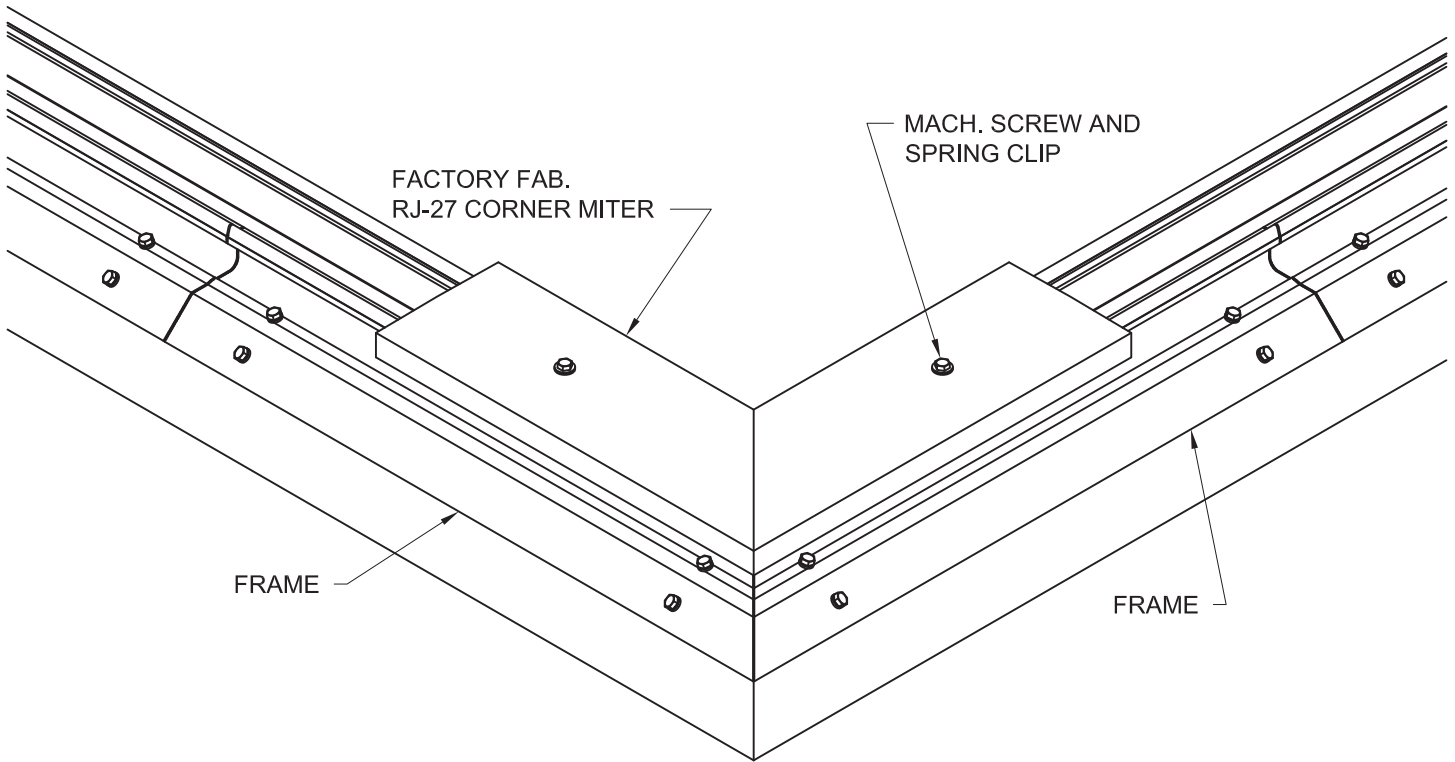

ISOMETRIC DETAIL  
AT 90° CORNER

Note: When factory fabricated Corner Miters and/or Transition Pieces are required, as indicated on the C/S shop drawings, these pieces are to be installed or positioned first so that the required length for the standard Cover Plates can be established.

4.1) Select the proper factory fabricated Corner Miter for the application as indicated on the C/S shop drawings.

4.2) Prepare and install or position the Corner Miter by following the proper RJ-27 and/or RJ-28 Cover Plate installation instructions as provided in Step 3.

# STEP 5

## INSTALL SPLICE PLATES

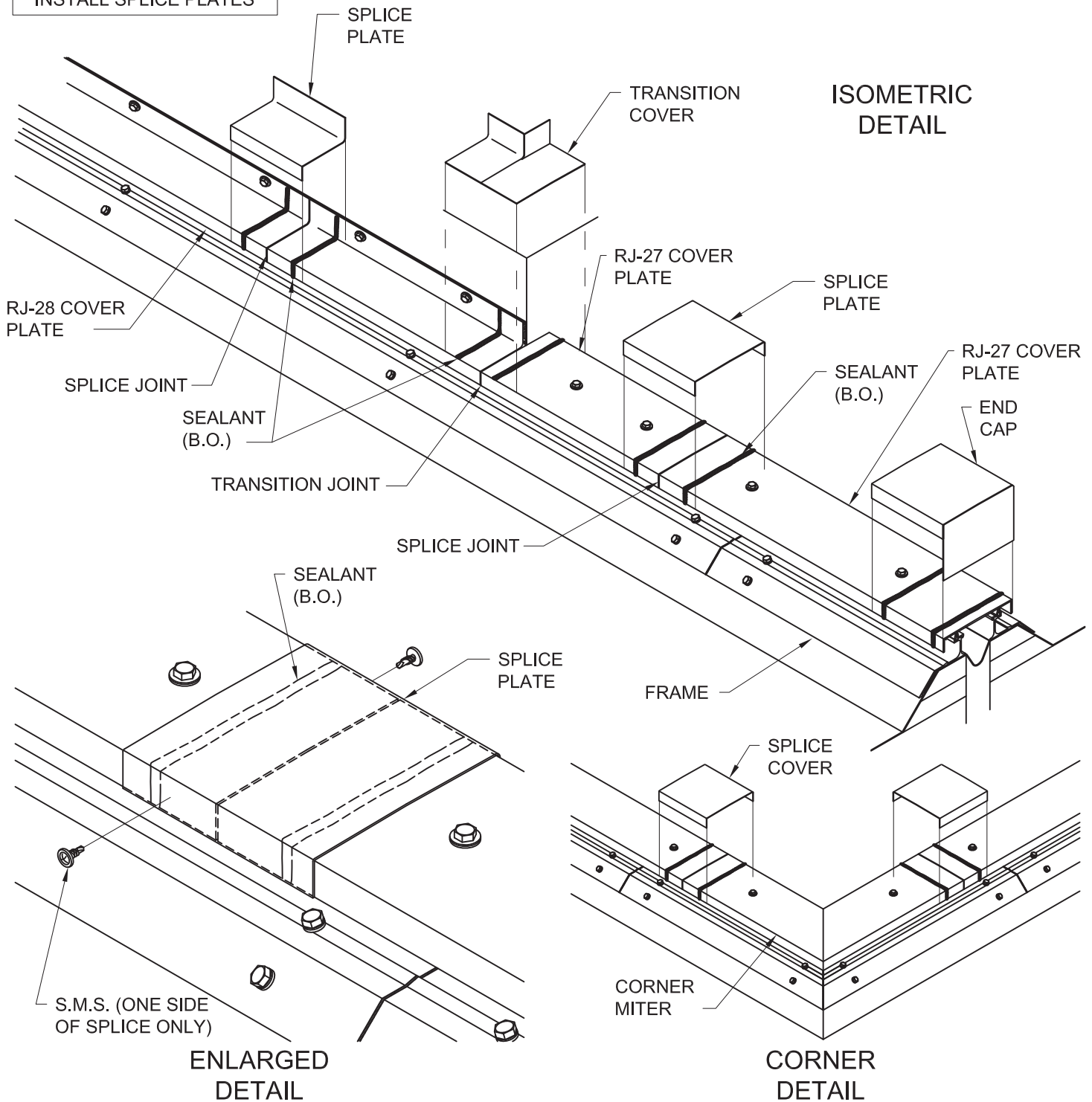

**Note:** Install factory fabricated Splice Covers at the splice joint between lengths of Cover Plates and between Cover Plates and Corner Miters and Transitions. Install End Caps and Transition Covers where required.

- 5.1) Place a bead of sealant (by others) across the full width of the Cover Plate, on each side of the splice joint.
- 5.2) Center the Splice Cover over the joint and seat the Splice Cover into the sealant, and fitting over the Cover Plate.
- 5.3) Attach the Splice Cover to the Cover Plate by inserting one self-drilling sheet metal screw into each vertical leg of the Splice Plate (one only at RJ-28), on one side of the splice joint. **Note:** Do not install screws on both sides of the splice joint as this will hinder thermal expansion movement.
- 5.4) Install Transition Cover with sealant only. **Note:** The Transition Cover cannot overhang the vertical sides of the Cover Plates due to differential movement that will occur at this location.

# STEP 6

COMPLETE INSTALLATION

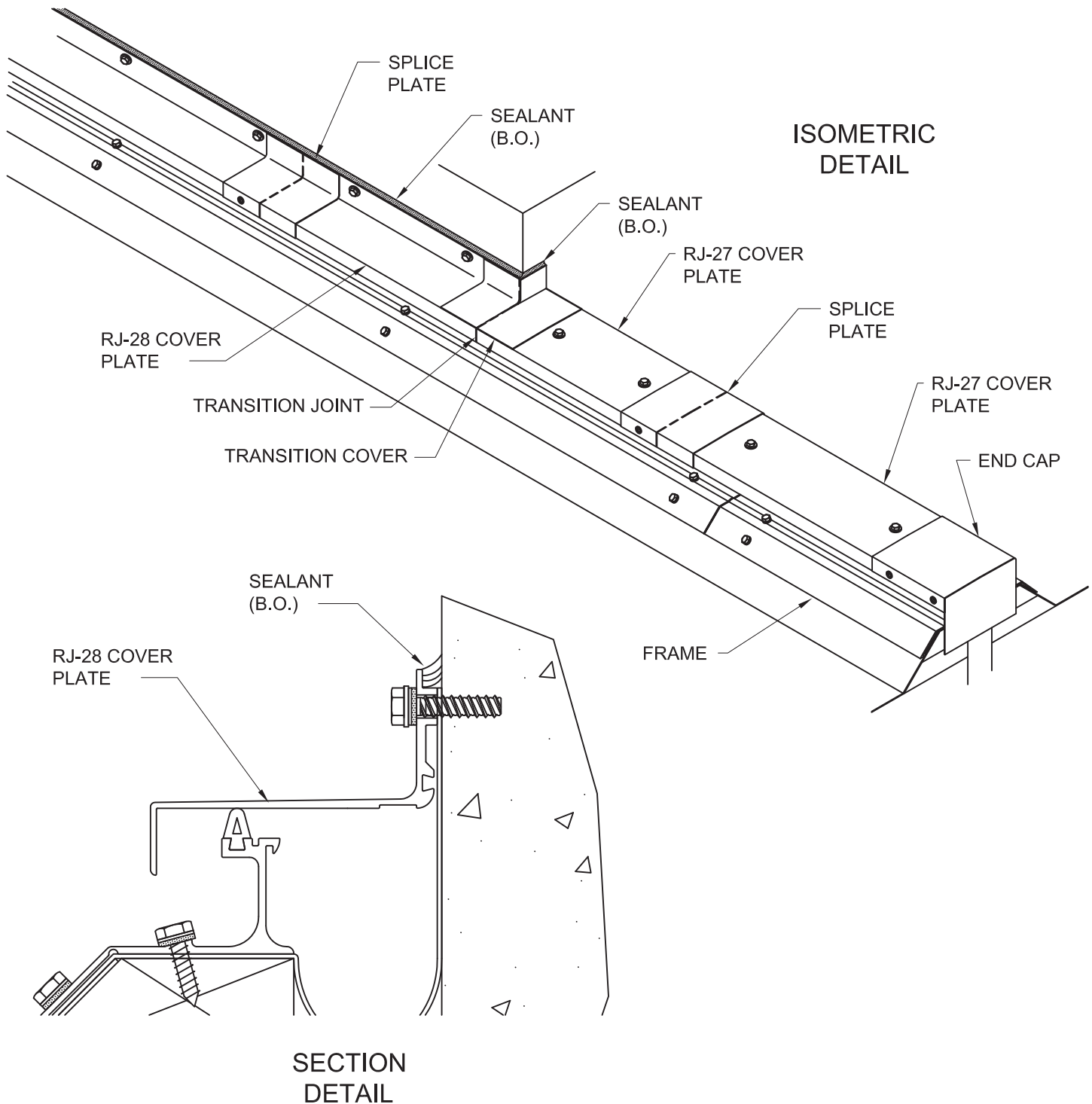

6.1) To complete the installation, apply sealant (by others) along the top recess of all RJ-28 Cover Plates.

6.2) At the RJ-27 to RJ-28 Transition Cover, apply sealant along the top and vertical edge of the leg that returns along the wall.

Note: Peel the protective plastic film off of all of the Splice Covers, End Caps and Transition Covers if not already done.

Installation is now complete.