

MODEL PC/PCW 100 THRU 400 INSTALLATION INSTRUCTIONS

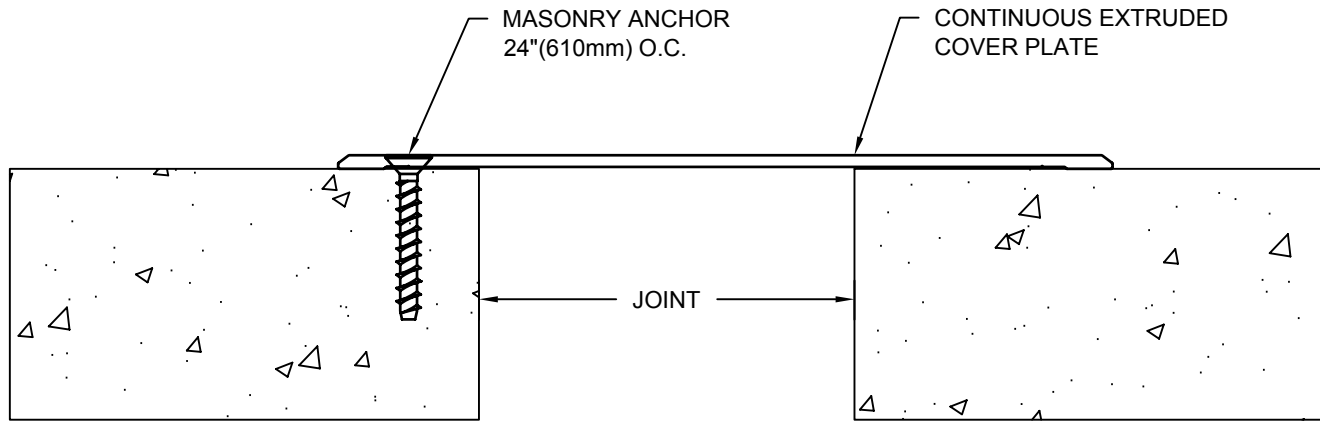

MODEL PC

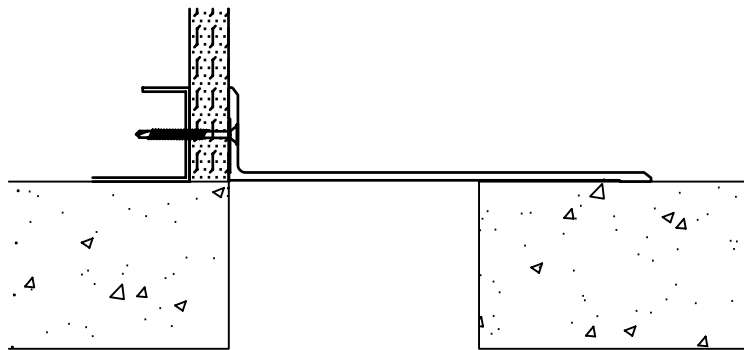

MODEL PCW

IMPORTANT INFORMATION

Prior to the commencement of Installation, all materials **MUST** be inspected for Damage. Any damage must be reported to CONSTRUCTION SPECIALTIES, INC., as soon as possible, so that replacement materials may be furnished without delay.

All work must be completed as per Architect's Approved "Shop Drawings", and in accordance with these Installation Instructions. When installation is complete, all materials must be protected from damage until the Architect's FINAL INSPECTION.

All materials should be arranged in the order that they are to be installed. All hardware required for each portion of the work should be placed with the appropriate materials.

Please review all Approved Shop Drawings and this Document to familiarize yourself with all the details and components of this assembly.

IMPORTANT:

READ THROUGH ALL INSTRUCTIONS PRIOR TO STARTING INSTALLATION

9/29/05

CONSTRUCTION SPECIALTIES, INC.

P.O. BOX 380
MUNCY, PA 17756
PHONE: (570)546-5941 FAX: (570)546-8022

This document is the property of Construction Specialties, Inc. and contains CONFIDENTIAL PROPRIETARY INFORMATION that is not to be disclosed to third parties and is not to be used without approval in writing from Construction Specialties, Inc.

Notes:

Before beginning installation, review the architectural drawings and approved Construction Specialties Inc. shop drawings to familiarize yourself with the joint cover models and locations.

Check all of the joint cover components to confirm that the correct joint cover model and size have been received. Also, check for materials that may have been damaged during shipping. Report all incorrect and/or damaged components to C/S at 800-233-8493.

Read through all the steps of these instructions prior to beginning work.

STEP 1

FLOOR COVER PLATE INSTALLATION

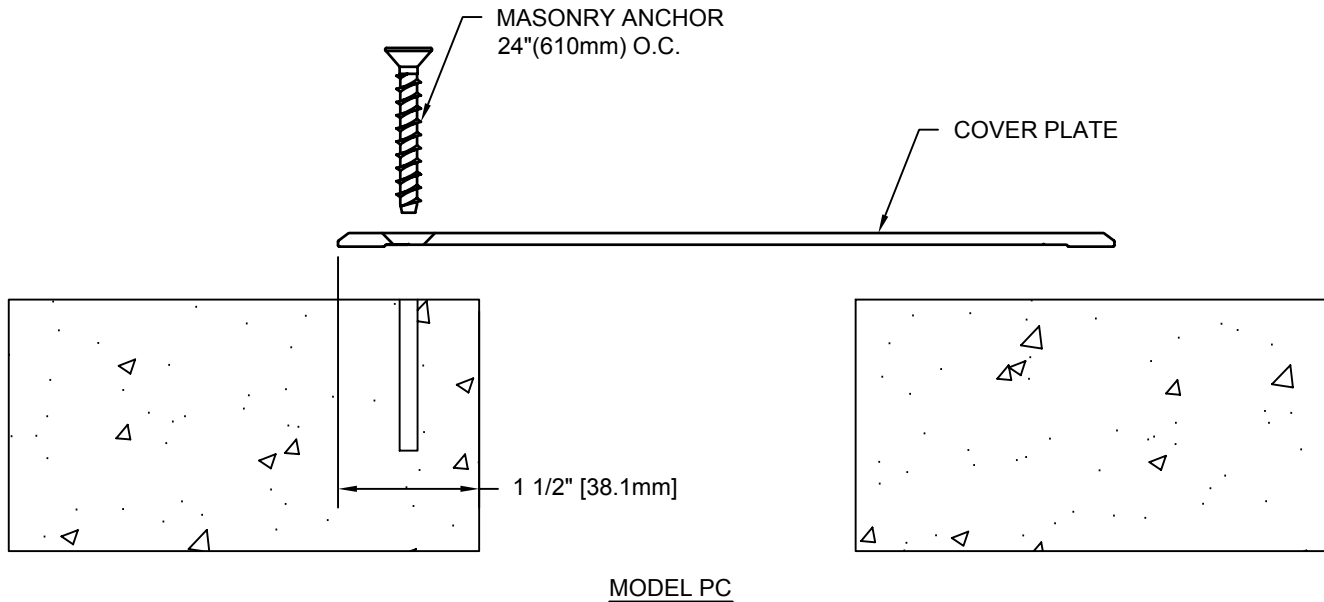

Note:

If a C/S Fire Barrier is to be installed in the joint, please review the Fire Barrier Installation Instructions supplied, and if required install the Fire Barrier **BEFORE** installation of C/S Seismic Expansion Joint Cover.

- If a Waterstop is to be installed in the joint, please review the Waterstop Installation Instructions supplied, and if required install the Waterstop **BEFORE** installation of C/S Seismic Expansion Joint Cover.

- 1.1) Begin installation of Cover Plate by placing a length of the Cover Plate over the joint. Cut the Cover Plate to length as needed.
- 1.2) Locate edge of Cover Plate 1-1/2" from edge of slab (see detail above).
- 1.3) Using the Cover Plate as a template, mark the locations for the C/S supplied anchor bolts.
- 1.4) Remove the Cover Plate and drill holes for the anchor bolts. The holes are to be drilled with the appropriate size and type of drill bit as indicated by the manufacturer of the anchor bolts, as supplied by C/S.
- 1.5) Reposition and anchor the Cover Plate to the slab with the C/S supplied anchor bolts following the manufacturer's guidelines.
- 1.6) Repeat the installation procedures for any additional lengths of Cover Plate.

STEP 2

FLOOR TO WALL COVER PLATE INSTALLATION

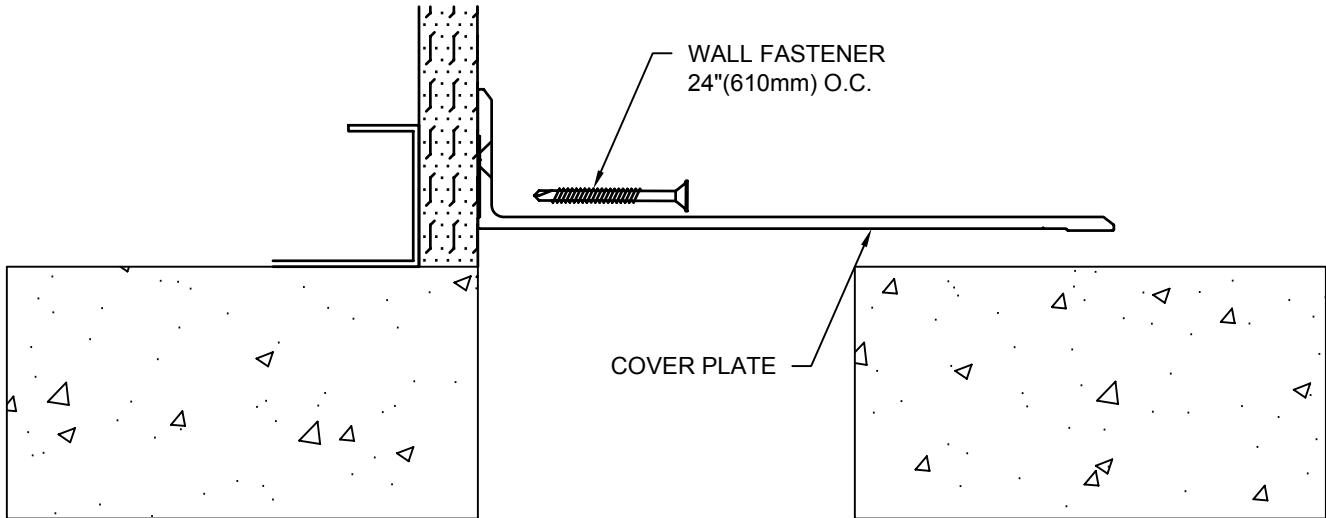

MODEL PCW

Note:

If a C/S Fire Barrier is to be installed in the joint, please review the Fire Barrier Installation Instructions supplied, and if required install the Fire Barrier **BEFORE** installation of C/S Seismic Expansion Joint Cover.

- If a Waterstop is to be installed in the joint, please review the Waterstop Installation Instructions supplied, and if required install the Waterstop **BEFORE** installation of C/S Seismic Expansion Joint Cover.

- 2.1) Begin installation of Cover Plate by centering a length of Cover Plate over joint and cutting to length as needed.
- 2.2) Using the Cover Plate as a template, mark the locations for the C/S supplied anchor bolts.
- 2.3) If needed, remove Cover Plate and drill holes for the anchor bolts. The holes are to be drilled with the appropriate size and type of drill bit as indicated by the manufacturer of the anchor bolts, as supplied by C/S.
- 2.4) Reposition and anchor the Cover Plate to the wall with the C/S supplied wall fasteners following the manufacturer's guidelines.
- 2.5) Repeat the installation procedures for any additional lengths of Cover Plate.

STEP 3

COMPLETE INSTALLATION

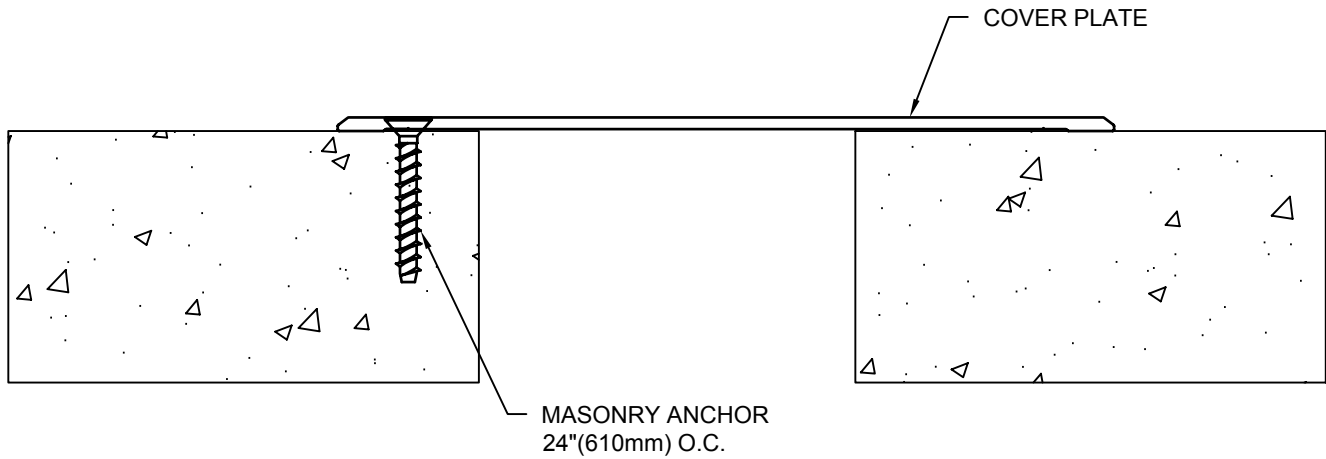

MODEL PC

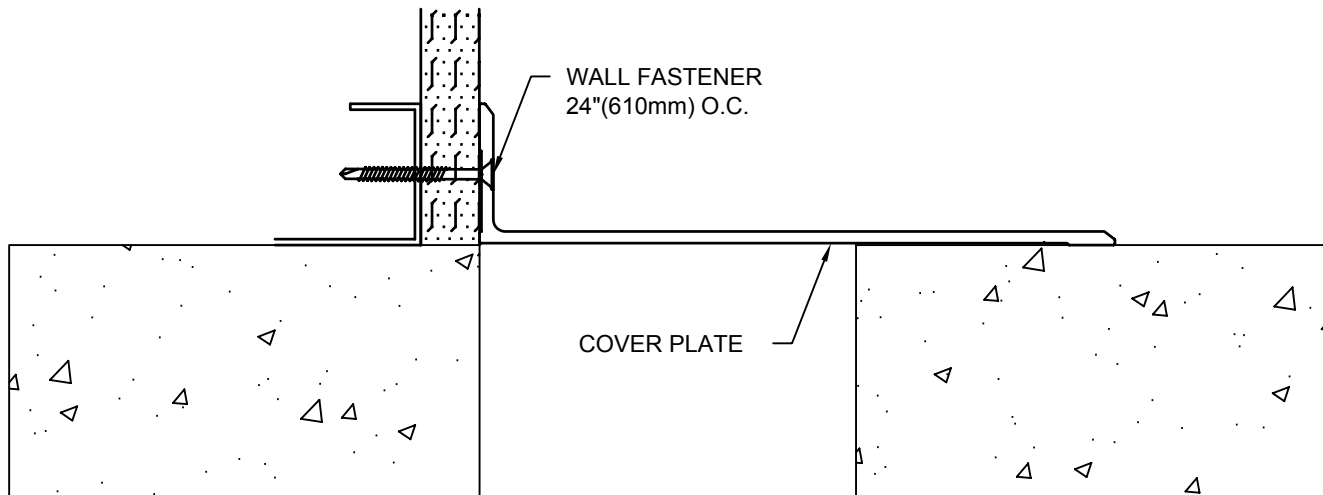

MODEL PCW

- 3.1) When installation of the C/S Floor Expansion Joint Cover has been completed, remove all residue and foreign matter from the area and joint cover.
- 3.2) Clean the C/S Joint Cover and adjoining surfaces with proper cleaner.
- 3.3) Protect the Joint Cover until the Architect's final inspection.