

MODEL GFS & GFSW INSTALLATION INSTRUCTIONS

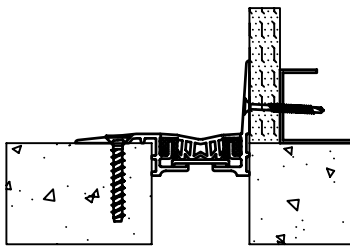
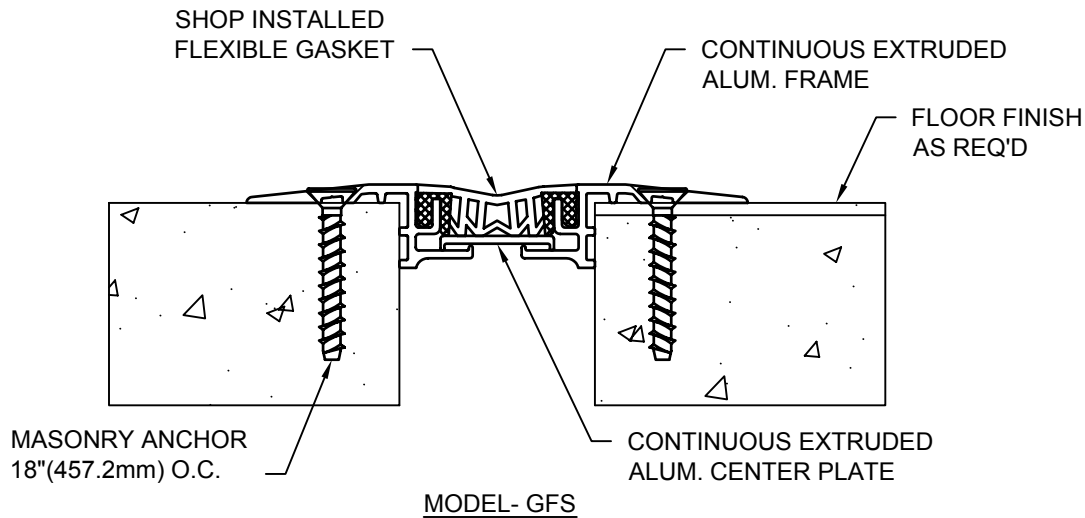

IMPORTANT INFORMATION

Prior to the commencement of Installation, all materials **MUST** be inspected for Damage. Any damage must be reported to CONSTRUCTION SPECIALTIES, INC., as soon as possible, so that replacement materials may be furnished without delay.

All work must be completed as per Architect's Approved "Shop Drawings", and in accordance with these Installation Instructions. When installation is complete, all materials must be protected from damage until the Architect's FINAL INSPECTION.

All materials should be arranged in the order that they are to be installed. All hardware required for each portion of the work should be placed with the appropriate materials.

Please review all Approved Shop Drawings and this Document to familiarize yourself with all the details and components of this assembly.

IMPORTANT:
READ THROUGH ALL INSTRUCTIONS PRIOR TO STARTING INSTALLATION

4/25/06

CONSTRUCTION SPECIALTIES, INC.

P.O. BOX 380

MUNCY, PA 17756

PHONE: (570)546-5941 FAX: (570)546-8022

This document is the property of Construction Specialties, Inc. and contains CONFIDENTIAL PROPRIETARY INFORMATION that is not to be disclosed to third parties and is not to be used without approval in writing from Construction Specialties, Inc.

Notes:

Before beginning installation, review the architectural drawings and approved Construction Specialties Inc. shop drawings to familiarize yourself with the appropriate joint cover models and locations.

Check all of the joint cover components to confirm that the correct joint cover model and size have been received. Also, check for materials that may have been damaged during shipping. Report all incorrect and/or damaged components to C/S at 800-233-8493.

Read through all the steps of these instructions prior to beginning work.

STEP 1

FRAME INSTALLATION

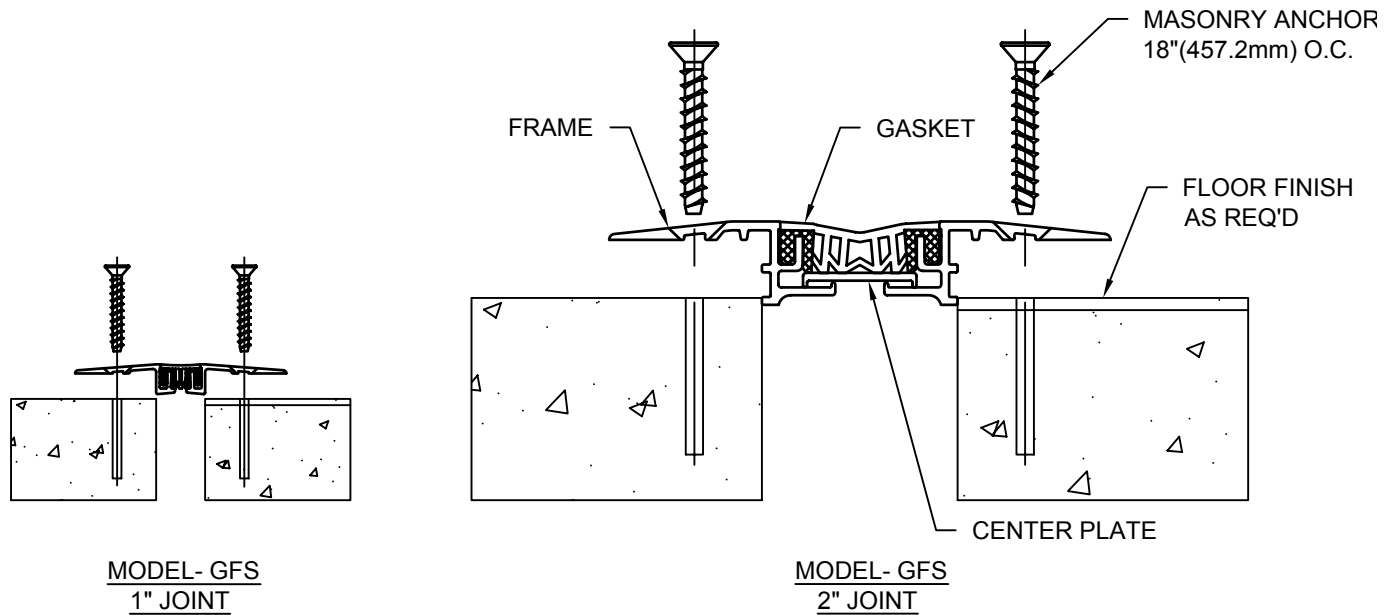

Notes:

-If a C/S Fire Barrier is to be installed in the joint, please review the Fire Barrier Installation Instructions supplied, and if required install the Fire Barrier **BEFORE** installation of C/S Seismic Expansion Joint Aluminum Frames.

-If a Waterstop is to be installed in the joint, please review the Waterstop Installation Instructions supplied, and if required install the Waterstop **BEFORE** installation of C/S Seismic Expansion Joint Aluminum Frames.

-Models GFS/GFSW are shipped pre-assembled.

- 1.1) Begin installation of the Assembly by placing a length of the Assembly into and over the edge of the slabs. Cut the Assembly to length as needed. Note the orientation of the Assembly in detail above.
- 1.2) Using the Frames as a template, mark the locations of the anchor bolts.
- 1.3) Remove the Assembly and drill the holes for the anchor bolts. The holes are to be drilled with the appropriate size and type of drill bit as indicated on the C/S Shop Drawings or by the manufacturer of the C/S supplied anchor bolts.
- 1.4) Reposition and attach the Assembly to the slab with the C/S supplied anchor bolts following the manufacturer's guidelines.
- 1.5) Repeat this installation procedure for any additional lengths of Assembly.

STEP 2

FLOOR TO WALL APPLICATION

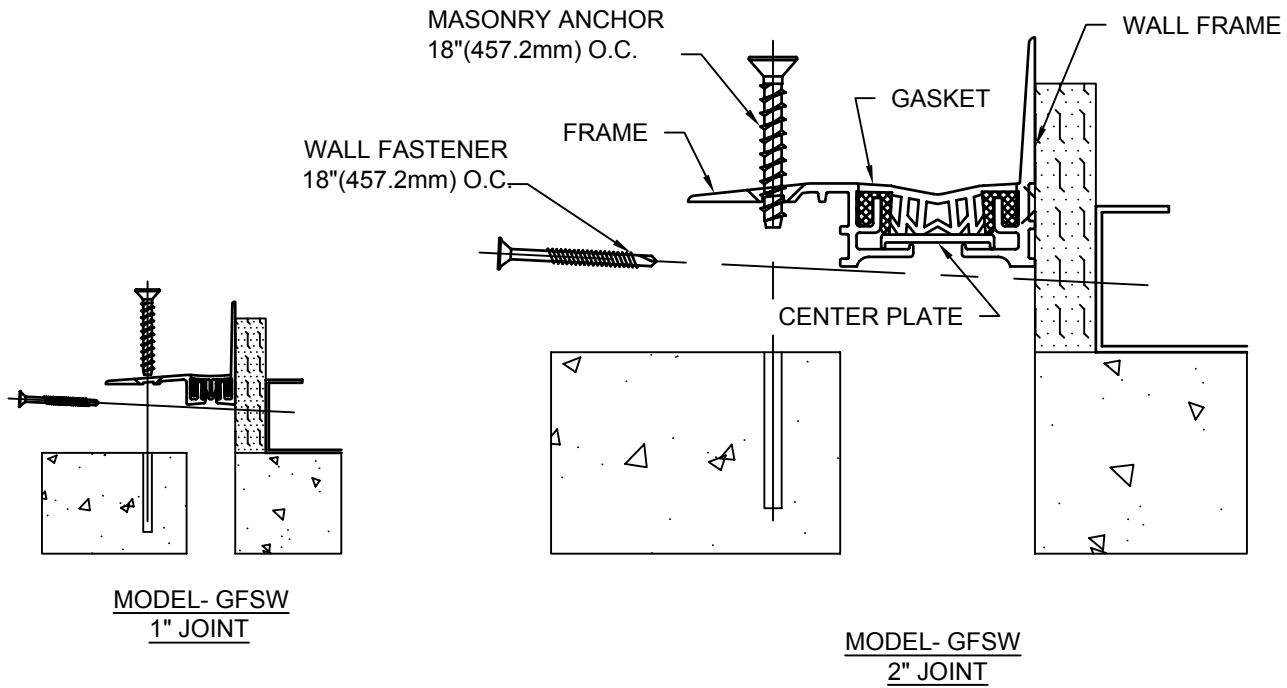

- 2.1) Begin installation of the Assembly by placing a length of the Assembly into the blockout. Cut the Assembly to length as needed. Note the orientation of the Assembly in detail above.
- 2.2) Center the Assembly over the joint and using the Assembly as a template, mark the locations of the anchor bolts.
- 2.3) Remove the Assembly and drill the holes for the anchor bolts. The holes are to be drilled with the appropriate size and type of drill bit as indicated on the C/S Shop Drawings or by the manufacturer of the C/S supplied anchor bolts.
- 2.4) Reposition and anchor the Assembly to the slab with the C/S supplied anchor bolts following the manufacturer's guidelines.
- 2.5) Attach Wall Frame to surface of the wall using C/S supplied wall fasteners.
- 2.6) Repeat this installation procedure for any additional lengths of Assembly.

STEP 3

COMPLETE INSTALLATION

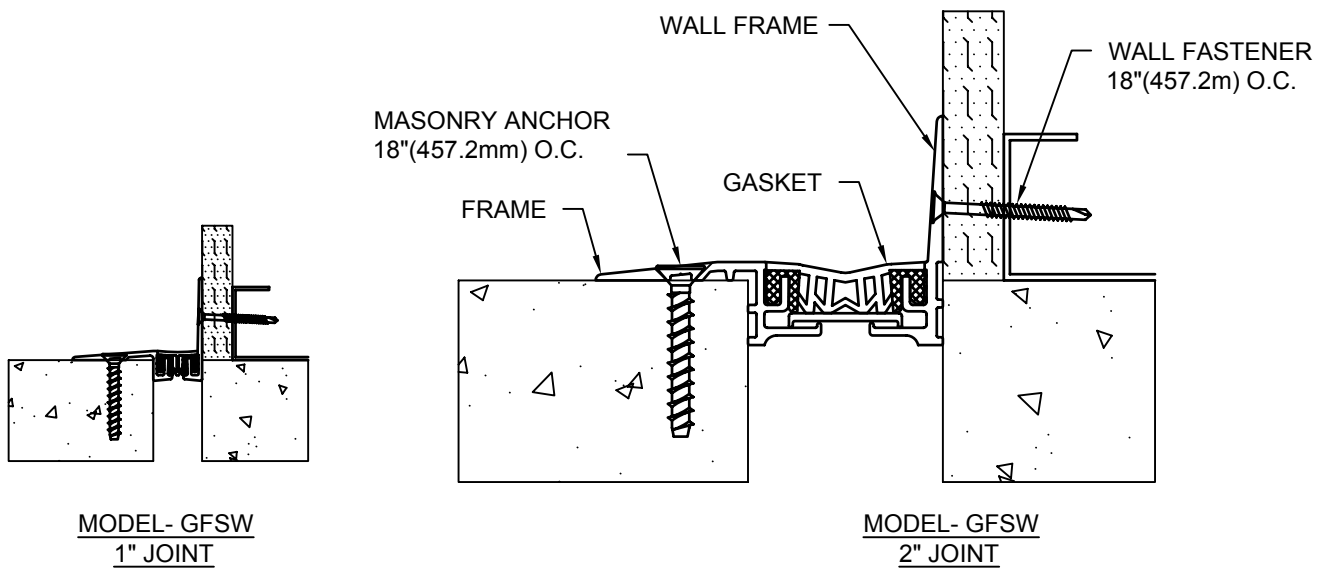
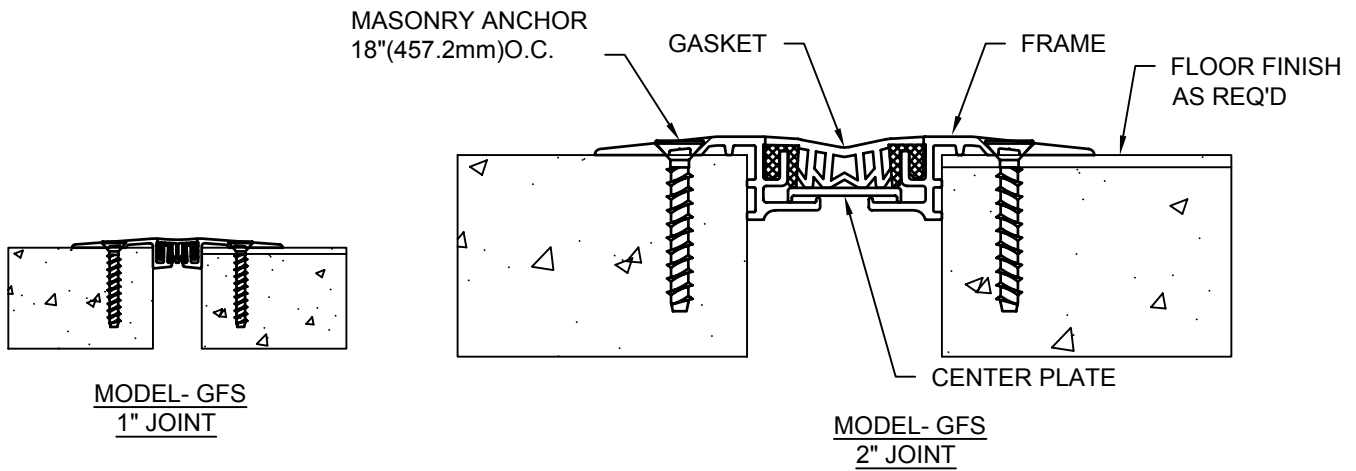

- 3.1) When installation of the C/S Floor Expansion Joint Cover has been completed, remove all residue and foreign matter from the area and joint cover.
- 3.2) Apply the appropriate floor finish as req'd.
- 3.3) Clean the C/S Joint Cover and adjoining surfaces with proper cleaner.
- 3.4) Protect the Joint Cover until Architect's final inspection.