

MODELS SF-200/500 AND SC-400 INSTALLATION INSTRUCTIONS

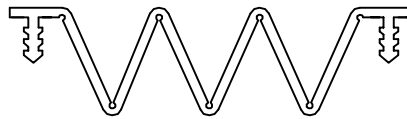

MODEL SC PRIMARY SEAL

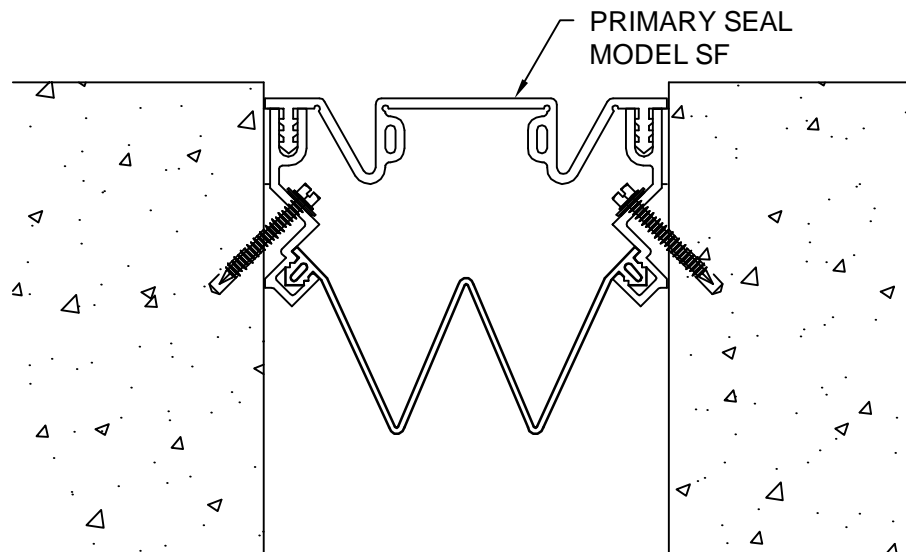

IMPORTANT INFORMATION

Prior to the commencement of Installation, all materials **MUST** be inspected for Damage. Any damage must be reported to CONSTRUCTION SPECIALTIES, INC., as soon as possible, so that replacement materials may be furnished without delay.

All work must be completed as per Architect's Approved "Shop Drawings", and in accordance with these Installation Instructions. When installation is complete, all materials must be protected from damage until the Architect's FINAL INSPECTION.

All materials should be arranged in the order that they are to be installed. All hardware required for each portion of the work should be placed with the appropriate materials.

Please review all Approved Shop Drawings and this Document to familiarize yourself with all the details and components of this assembly.

IMPORTANT:
READ THROUGH ALL INSTRUCTIONS PRIOR TO STARTING INSTALLATION

5/9/1F



Construction Specialties™

6696 Route 405 Highway, Muncy PA 17756
(800) 233-8493 .Fax (570) 546-5169 www.c-sgroup.com

This document is the property of Construction Specialties, Inc. and contains CONFIDENTIAL PROPRIETARY INFORMATION that is not to be disclosed to third parties and is not to be used without approval in writing from Construction Specialties, Inc.

Notes:

Before beginning installation, review the architectural drawings and approved Construction Specialties Inc. shop drawings to familiarize yourself with the joint cover models and locations.

Check all of the joint cover components to confirm that the correct joint cover model and size have been received. Also, check for materials that may have been damaged during shipping. Report all incorrect and/or damaged components to C/S at 800-233-8493.

Read through all the steps of these instructions prior to beginning work.

STEP 1

BASE CLOSURE INSTALLATION

Base Closures are installed at the bottom of a run of Exterior Wall Cover or a transition between joint widths in a single run of exterior expansion joint cover (See approved C/S Shop Drawings for locations). The size of the base closure is determined by the joint width.

IMPORTANT NOTE:

Actual field conditions may differ from shown.

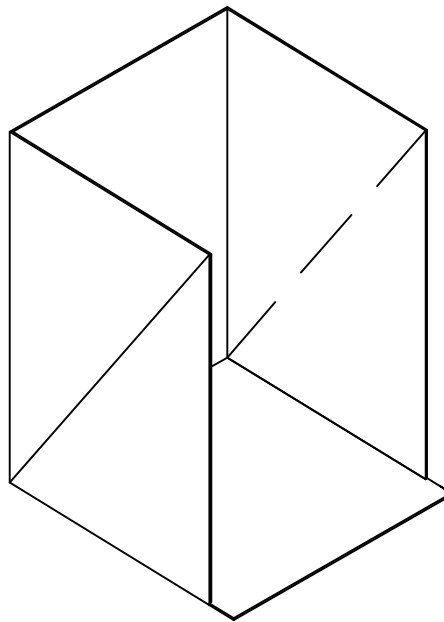

Step 1:

- 1.1 Locate the center in the width of the sheet. Fold and crease. (See diagram 1:1)
- 1.2 Fold the length of the sheet into 3 equal sections. (Fold and crease - See diagram 1:2)
- 1.3 Create a 1" center tab by trimming off 1" from each end section. (See diagram 1:3 to create diagram 1:4))
- 1.4 Fold width of sheet in half and fold the top outside corners down. (Fold and crease - see diagram 1:5 & 1:6)
- 1.5 Open sheet (See diagram 1:7) Fold outside center points of A & B together and C & D together, creating two flaps. (See diagram 1:8)
- 1.6 Remove the paper backing from one side of joint tape. Apply strips of joint tape along A to B line, along C to D line and along the outside edge of each. (See diagram 1:9) For joint sizes 6" or larger apply 2 strips.
- 1.7 Remove the paper backing from the other side of the joint tape and fold point A to B & C to D. Press firmly into place creating a folded flap. (See diagram 1:10)
- 1.8 Remove the paper backing from one side of joint tape, apply a strip of joint tape along tape edges (top and along diagonal edge) of folded flap. (See diagram 1:10)
- 1.9 Remove paper backing from the other side of joint tape and fold flap to side of base closure. Press firmly into place. (See diagram 1:11 A & B)
- 1.10 Apply a continuous bead of C/S supplied polyurethane caulk along each inside seam of the base closure. Be sure to apply enough caulk along the seams and in the corners to create a water tight seal.

STEP 1 CON'T

BASE CLOSURE INSTALLATION

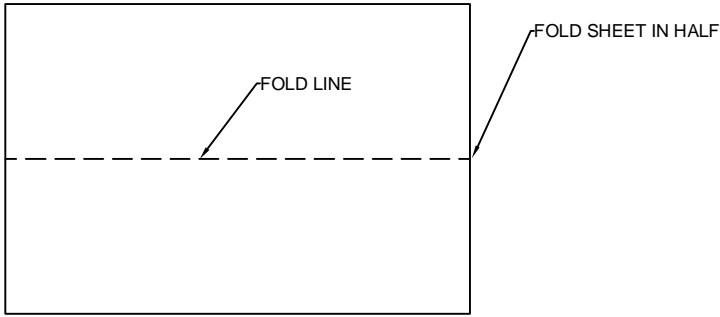

DIAGRAM 1:1

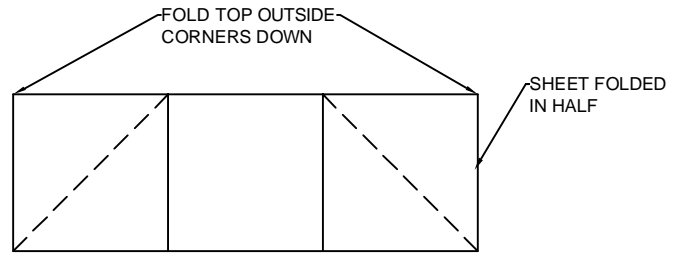

DIAGRAM 1:5

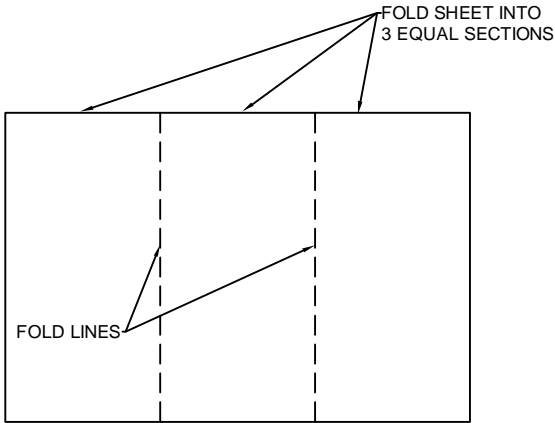

DIAGRAM 1:2

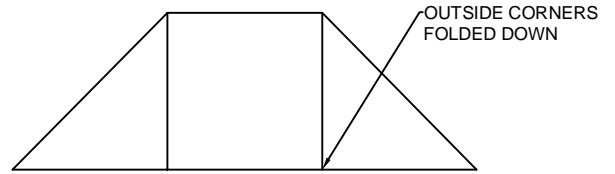

DIAGRAM 1:6

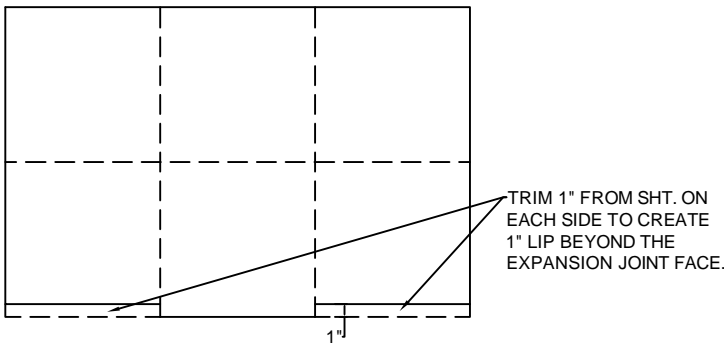

DIAGRAM 1:3

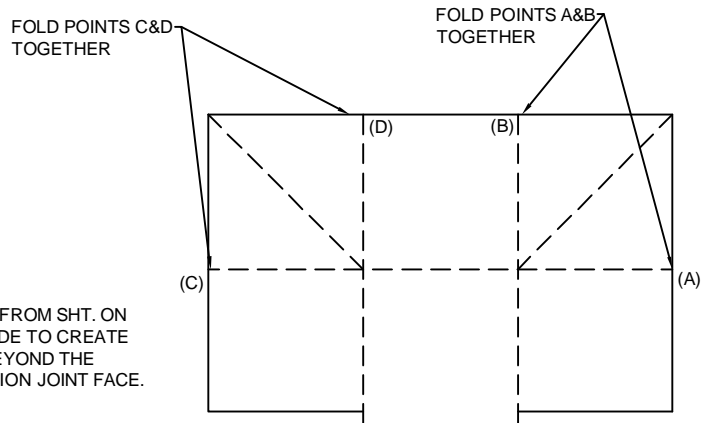

DIAGRAM 1:7

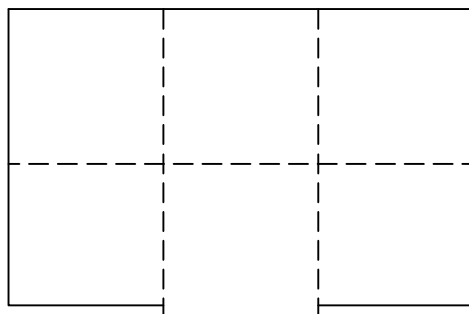

DIAGRAM 1:4

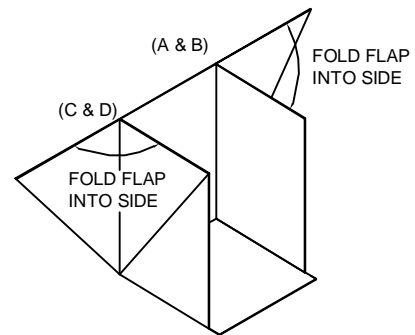
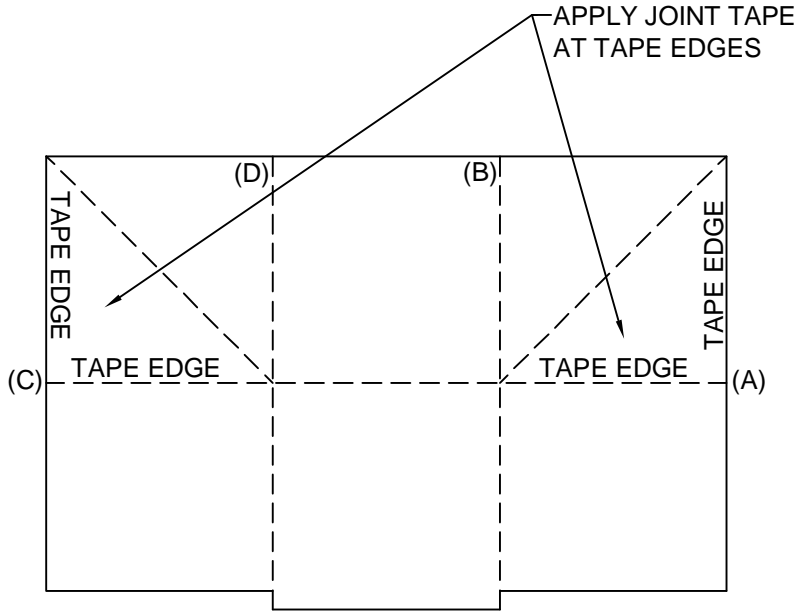

DIAGRAM 1:8

STEP 1 CON'T

BASE CLOSURE INSTALLATION



JOINT TAPE LOCATIONS IN PLAN VIEW
DIAGRAM 1:9

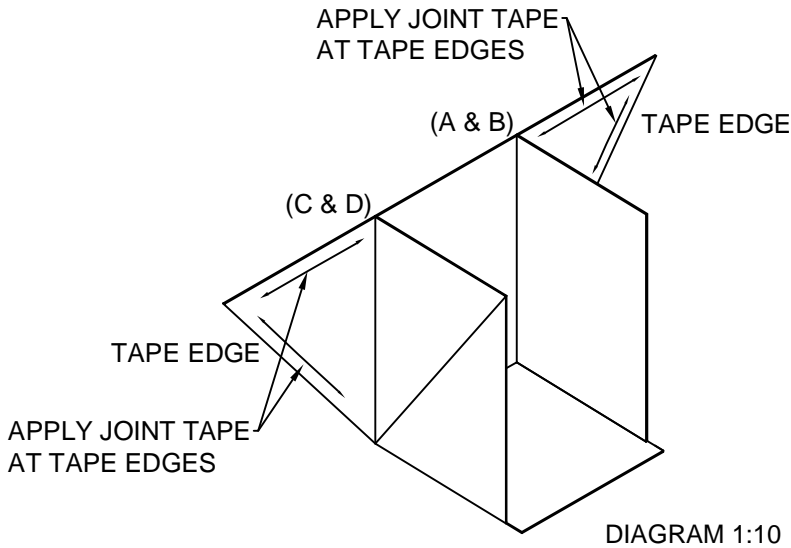

DIAGRAM 1:10

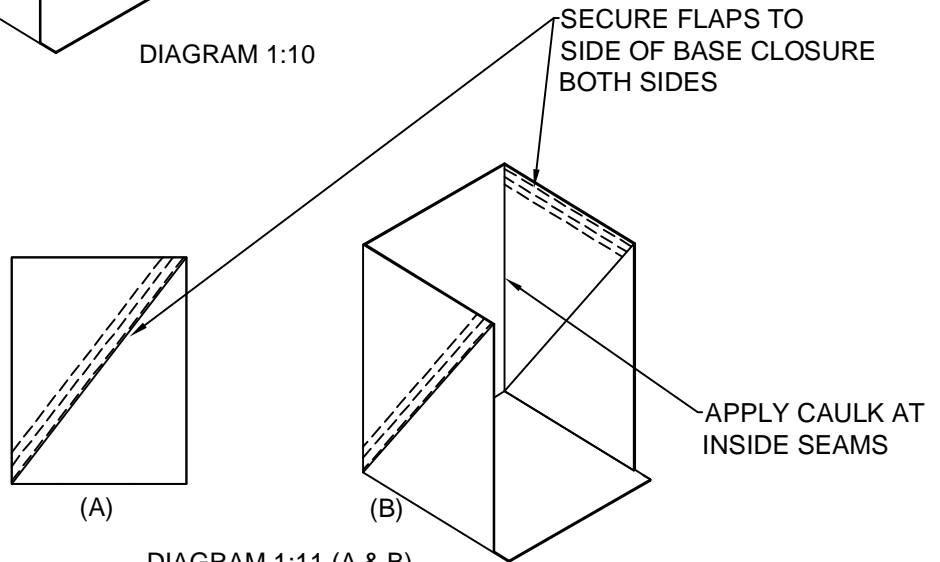
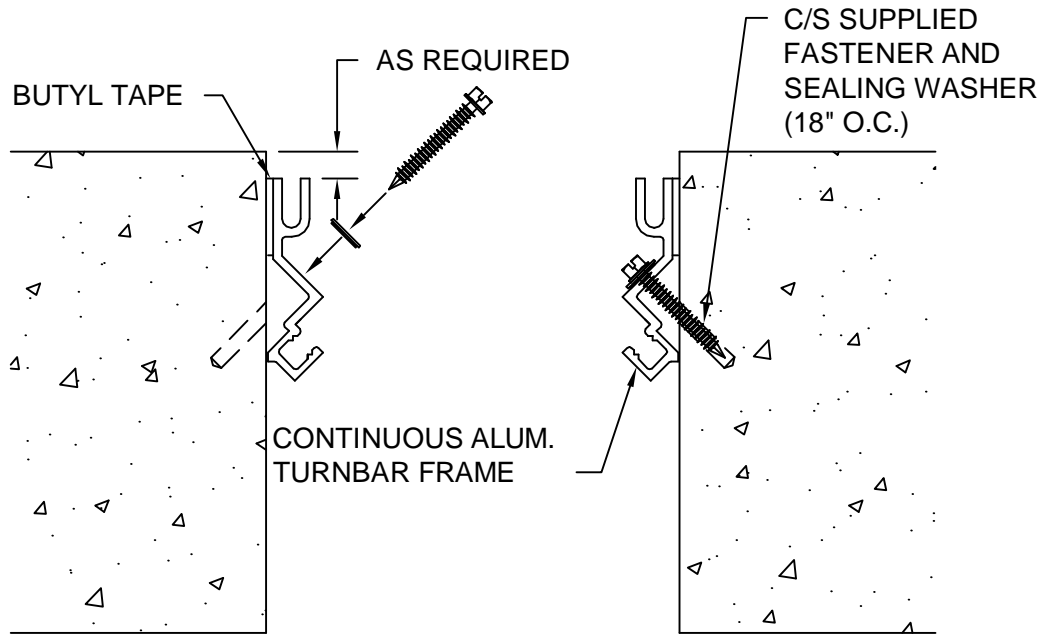

DIAGRAM 1:11 (A & B)

STEP 2

INSTALLATION OF ALUMINUM FRAMES AND BUTYL TAPE



Step 2:

1. Apply the C/S supplied Butyl Tape to the back of the Aluminum Frames.
2. Beginning at one end of the run, start installation of the Frames by peeling the paper backing off of the Butyl Tape and seat the frames at the appropriate location with the joint.
3. Using the Frame as a template, drill the holes for the C/S supplied Fasteners and anchor the Frames into the joint. Note: Do not forget to use the C/S supplied Sealing Washer with each Fastener.
4. Continue with installation of the Aluminum Frames until all of the Frames, on both sides of the joint, for the entire run are installed.
5. Each Aluminum Frame is double punched to accept either a masonry anchor or a TEK screw with a Sealing Washer depending on the installation condition. All holes that do not receive a fastener and all frame butt joints should be caulked with the C/S supplied Sikaflex 1A.

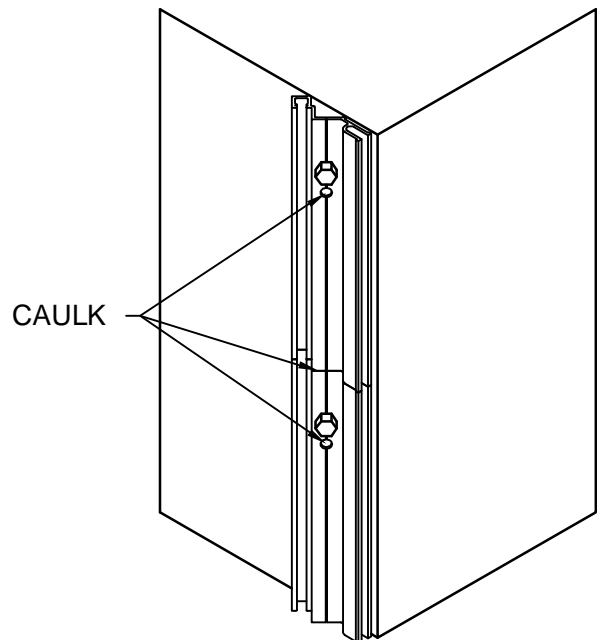

STEP 3

SECONDARY SEAL INSTALLATION

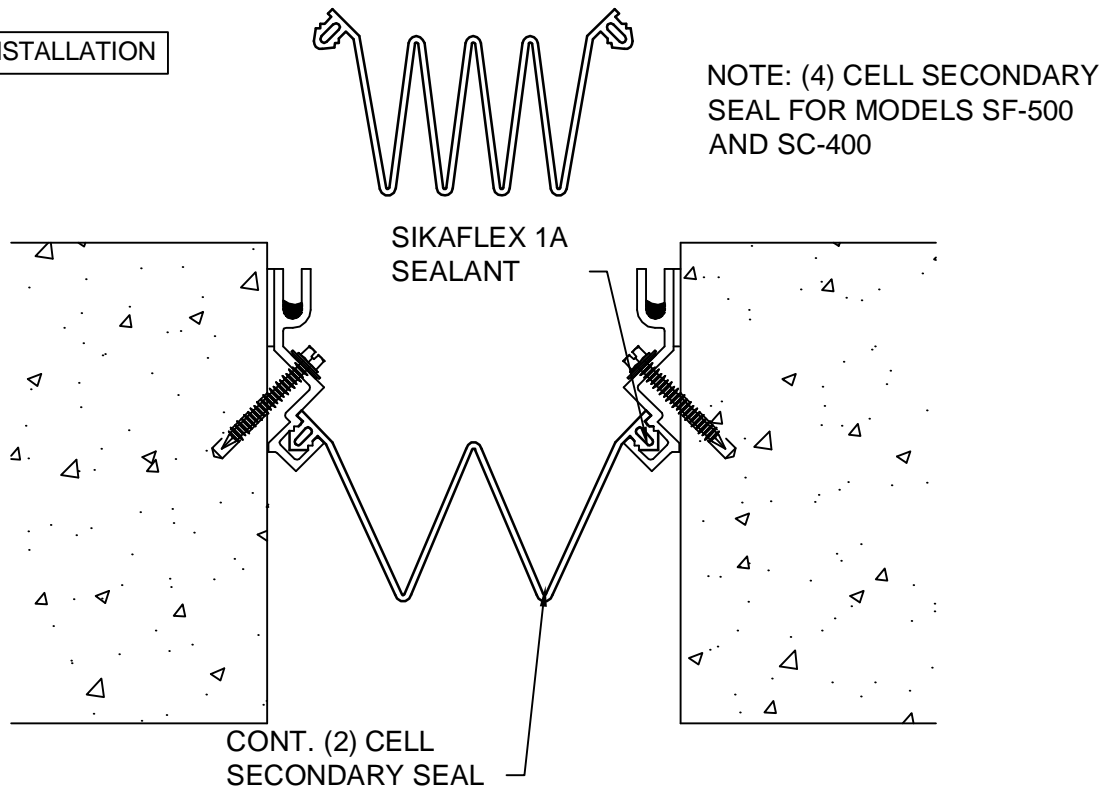

Step 3:

1. Place a small bead of the C/S supplied Sikaflex 1A Urethane Sealant into the secondary seal receiver slot of each Frame.
2. Starting at the top of the run, install the Secondary Seal into the Aluminum Frames by pushing the seal tabs into the receiver slots. When required, splice joints in the secondary seal are to be overlapped by 6", top over bottom, and sealed with the Sikaflex 1A Sealant.

STEP 4

PRIMARY SEAL INSTALLATION

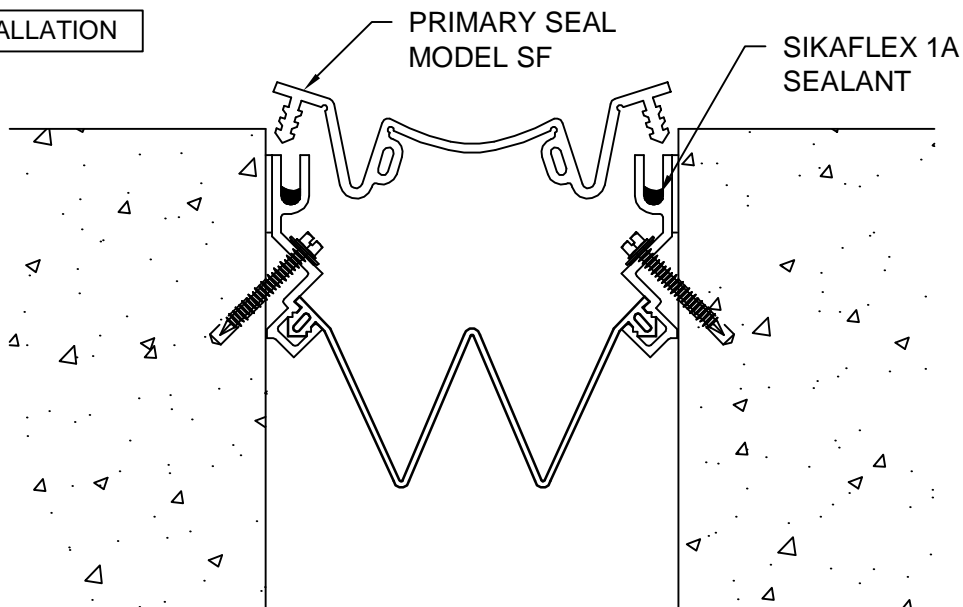

Step 4:

1. Prior to installation of the Primary Seal, place a 1/8" to 3/16" bead of Sikaflex 1A Sealant into the Primary Seal receiver slot of each Aluminum Frame. Note: Application of the Sealant will aid in the installation of the seal and will improve the water resistance of the cover.
2. Cut the Primary Seal to length as needed for the run. When necessary, multiple lengths of seal may have to be spliced together for the required length of the run. (See Step 5 for cutting and splicing instructions.)
3. Beginning at the top of the run, insert the tabs on the Primary Seal into the receiver slots of the frames. Use a mallet and wood block to seat the seal against the front of the frames.

STEP 5

SPLICE INSTRUCTIONS

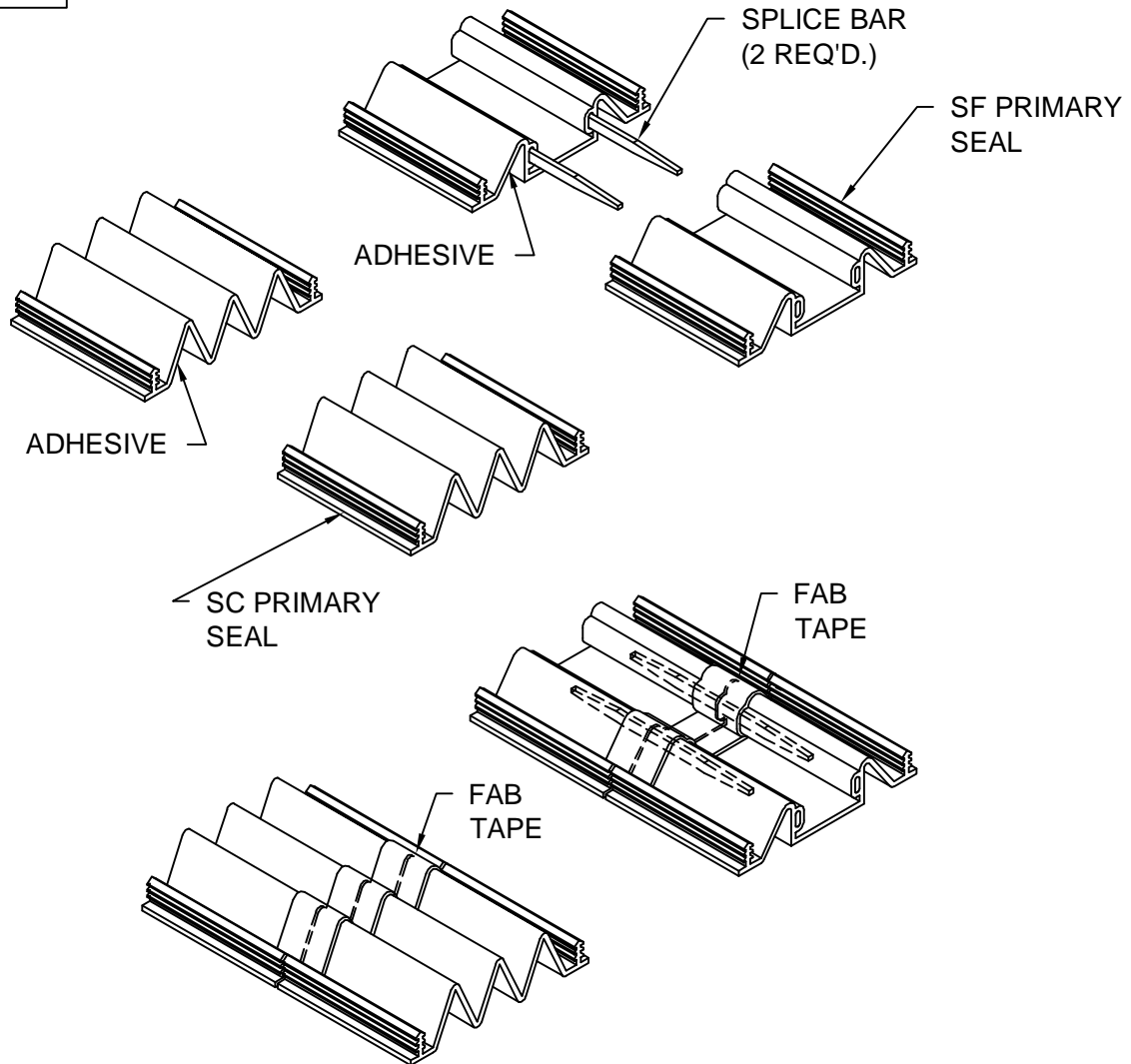

PRIMARY SEAL SPLICE

Step 5:

Cutting:

- 1) Determine the length of seal required for the applicable area and measure and mark the seal.
- 2) Place the seal with the location to be cut into a Miter Box and flood the area to be cut with water to lubricate the saw blade.
- 3) Using a hacksaw and the C/S supplied Serrated Saw Blade, make the cut using long strokes while applying downward force on the Hacksaw frame. The cut should be made with as few strokes as possible in order to prevent a ragged end on the seal.

Splicing:

- 1) Wipe surface of the Splice Bars and the ends of the seals to be bonded with Alcohol (or similar) to remove all dirt, moisture, and oils that might affect the bond.
- 2) When appropriate, apply the 3M CA-40 Adhesive to half of each Splice Bar. Insert only the portion of the bar with adhesive into the splice bar slot of one of the seals. Important: Please observe the safety precautions on the adhesive container!
- 3) Apply the CA-40 Adhesive to the entire cut surface of the seal and the remaining portion of the Splice Bar.
- 4) Align the two ends of each seal, insert the Splice Bar into the opposite seal and bring the ends of the seal together. Apply pressure against the ends of the seals until the Adhesive has set.
- 5) Once the Adhesive has cured, cut a piece of the Fab Tape that is wide enough to span across the entire width of the backside of the seal splice. Place the tape so that it is centered over the butt joint and press the tape firmly against the back of the seal to work the tape into all voids to create a watertight seal.