

# MODEL SJPW-100 THRU 1600 INSTALLATION INSTRUCTIONS

12YY

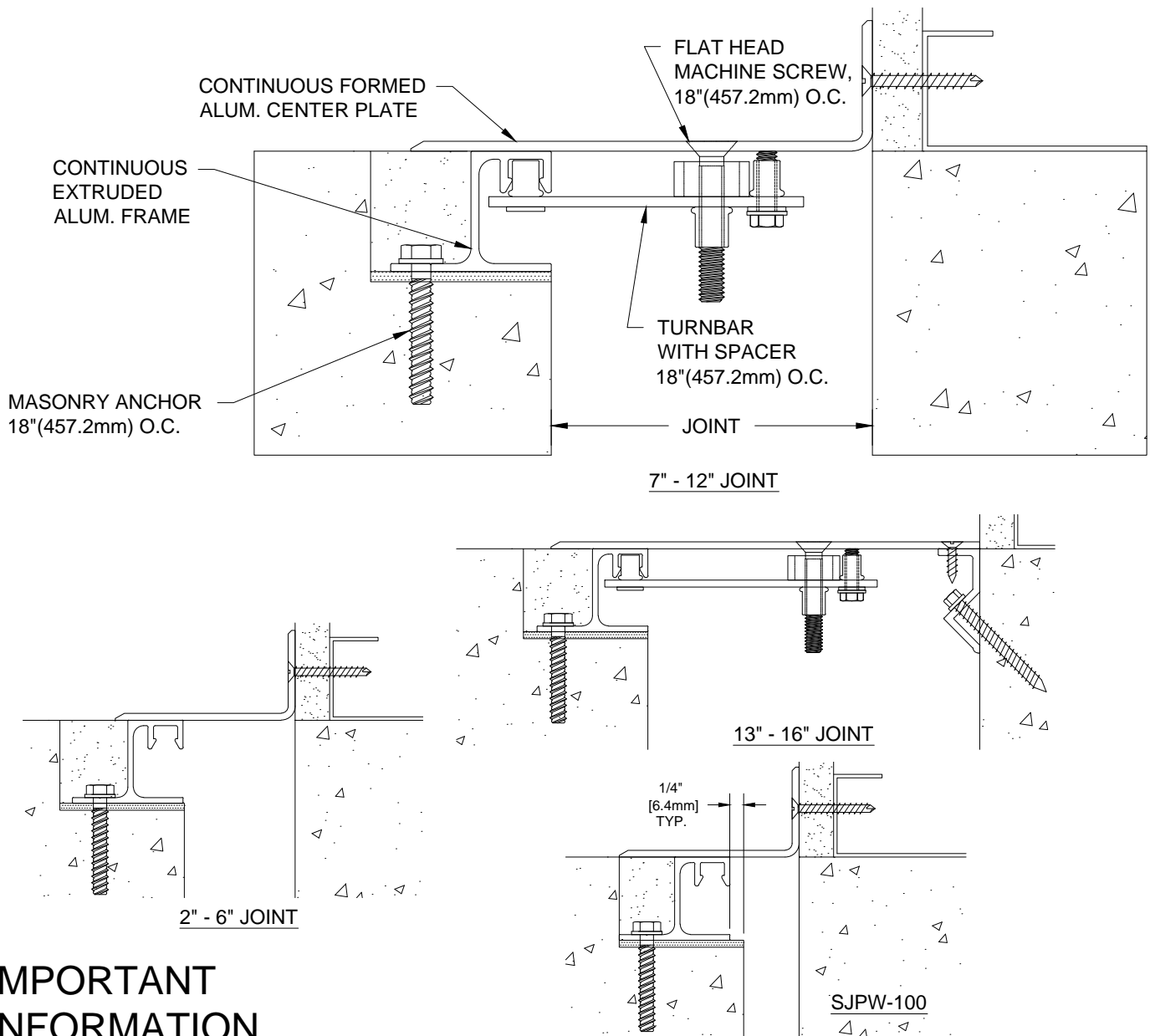

## IMPORTANT INFORMATION

Prior to the commencement of installation, all materials **MUST** be inspected for damage. Any damage must be reported to CONSTRUCTION SPECIALTIES, INC., as soon as possible, so that replacement materials may be furnished without delay.

All work must be completed as per Architect's Approved "Shop Drawings", and in accordance with these Installation Instructions. When installation is complete, all materials must be protected from damage until the Architect's FINAL INSPECTION.

### IMPORTANT:

**READ THROUGH ALL INSTRUCTIONS PRIOR TO STARTING INSTALLATION**

All materials should be arranged in the order that they are to be installed. All hardware required for each portion of the work should be placed with the appropriate materials.

Please review all Approved Shop Drawings and this document to familiarize yourself with all the details and components of this assembly.

8/5/11



**Construction Specialties™**

6696 Route 405 Highway, Muncy PA 17756  
(800) 233-8493 . Fax (570) 546-5169 . www.c-sgroup.com

This document is the property of Construction Specialties, Inc. and contains CONFIDENTIAL PROPRIETARY INFORMATION that is not to be disclosed to third parties and is not to be used without approval in writing from Construction Specialties, Inc.

**Notes:**

Before beginning installation, review the architectural drawings and approved Construction Specialties Inc. shop drawings to familiarize yourself with the appropriate joint cover models and locations.

Check all of the joint cover components to confirm that the correct joint cover model and size have been received. Also, check for materials that may have been damaged during shipping. Report all incorrect and/or damaged components to C/S at 800-233-8493.

Read through all the steps of these instructions prior to beginning work.

# STEP 1

## PREPARE BLOCKOUTS

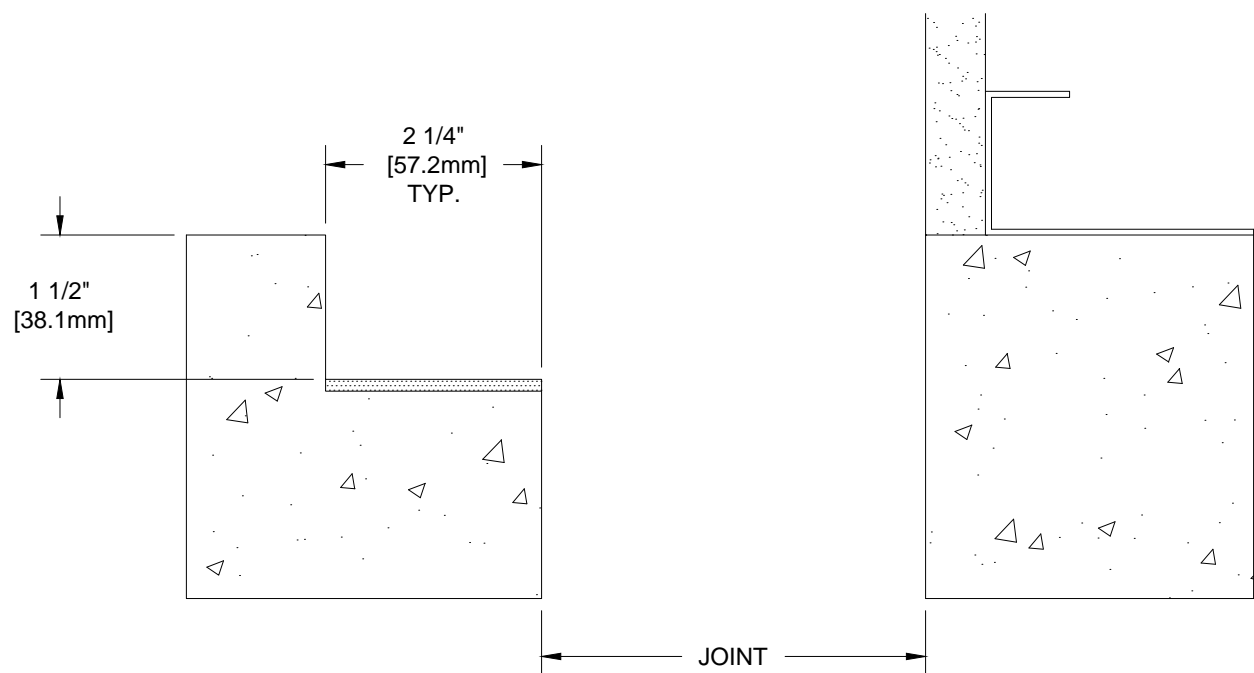

- 1.1) The blockouts must be prepared to receive the joint cover.
  - For Model SJPW the blockout depth will typically be 1-1/2"(38.1mm). However, the depth may be adjusted as needed to accommodate a floor finish material when required and as indicated on the architectural drawings and/or C/S shop drawings.
  - It is recommended that the blockout be formed a minimum of 1/8" deeper to allow the blockouts to be leveled for installation of the joint cover.
  - Apply a high-strength leveling grout to the base of the blockouts to provide a continuous, solid, flat and level base for the joint cover. (Note: The blockouts must be level across the width of the joint.)

# STEP 2

## SPACER INSTALLATION (7" -16" JOINT)

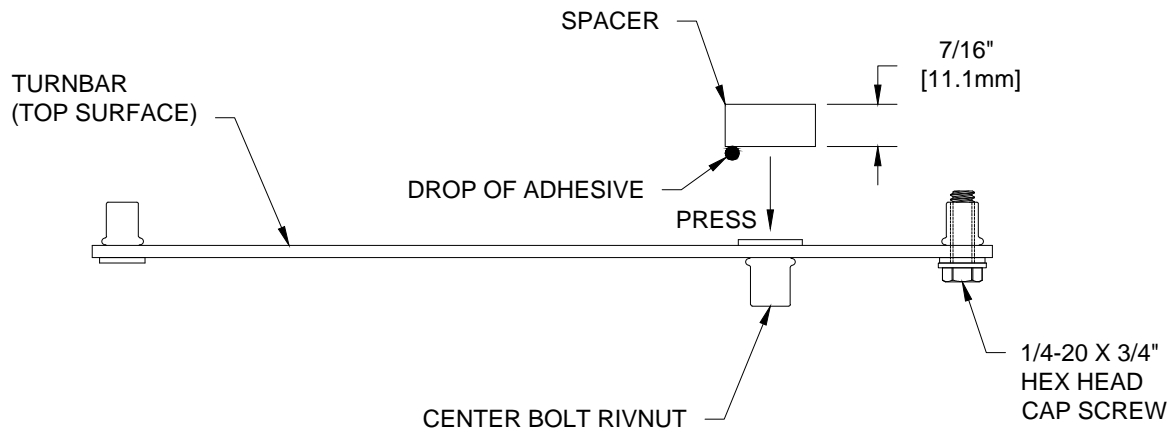

A Spacer must be placed between the Turnbar and the underside (or backside) of the cover plate. The Spacer is used to prevent excess bowing of the Turnbars when the center bolt is tightened. (Some bowing of the Turnbars is required to apply the holding force on the cover plate.) (Note: 1" - 6" models do not require turnbars, so this step can be skipped.)

Spacer Installation:

- 2.1) Place a small drop of "super glue" adhesive (not supplied) onto one end of a Spacer.
- 2.2) Position the end of the Spacer with the adhesive against the top surface of the Turnbar, centered over the flat head portion of the Center Bolt Rivnut. (See detail above.)
- 2.3) Press firmly for a few seconds until the Spacer is bonded to the Turnbar.
- 2.4) Install the Turnbars as instructed.

# STEP 3

## BASE FRAME INSTALLATION

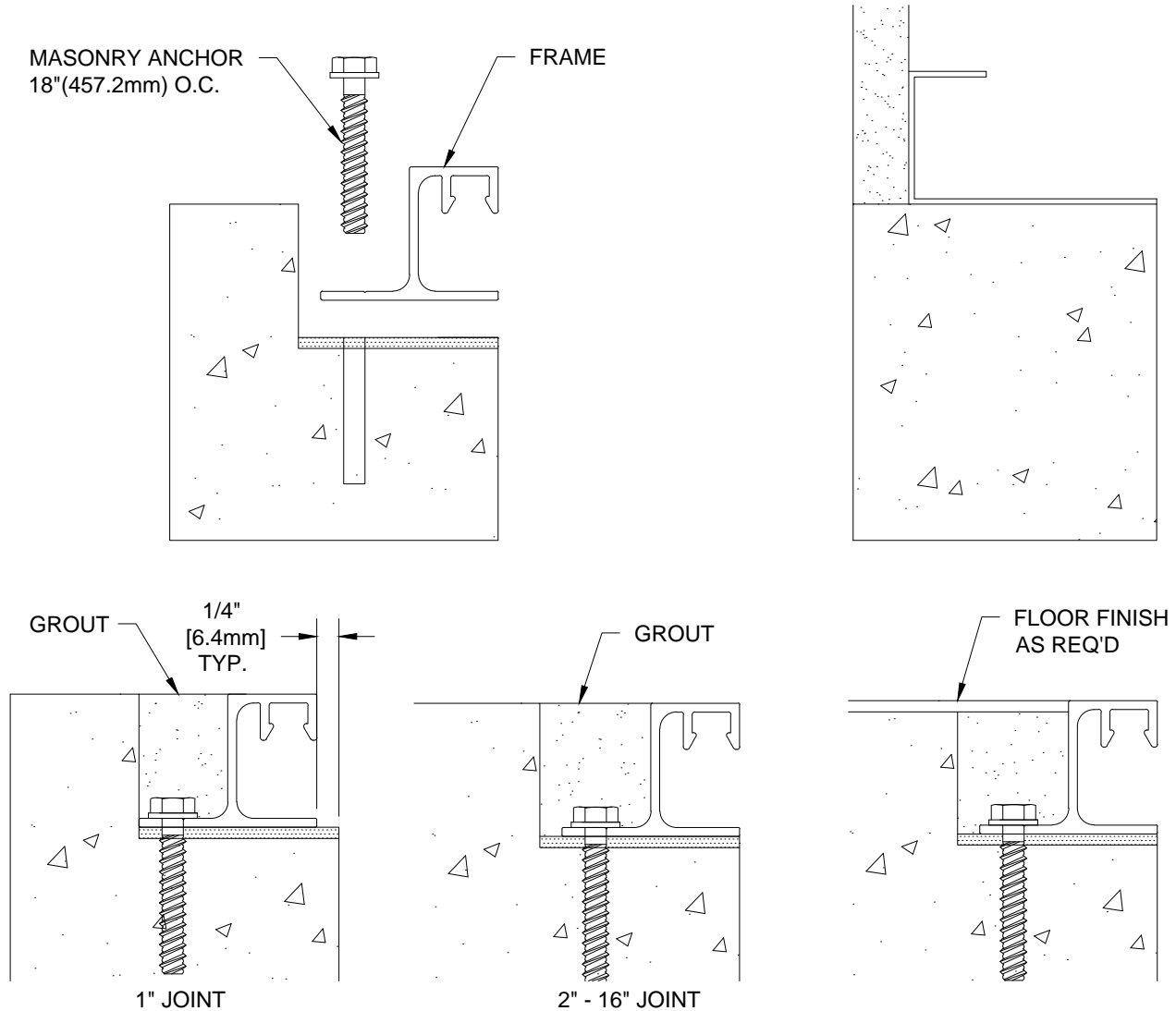

### Notes:

-If a C/S Fire Barrier is to be installed in the joint, please review the Fire Barrier Installation Instructions supplied, and if required install the Fire Barrier **BEFORE** installation of C/S Seismic Expansion Joint Aluminum Frames.

-If a Waterstop is to be installed in the joint, please review the Waterstop Installation Instructions supplied, and if required install the Waterstop **BEFORE** installation of C/S Seismic Expansion Joint Aluminum Frames.

3.1) Begin installation of the Frame by placing a length of Frame into the breakout. Cut the Frame to length as needed. The Frame is to sit level, flat and parallel to the edge of the joint. The Frame should not overhang the edge of the slab or sit above the top surface of the slab, except to accommodate a floor finish.

**\*\*Note:** SJPW-100, place frames 1/4" [6.4m] back from the edge of the joint.\*\*

3.2) Using the Frame as a template, mark the locations in the breakout for the anchor bolts. Remove the Frame and drill the holes for the anchor bolts. The holes are to be drilled with the appropriate size and type of drill bit as indicated by the manufacturer of the anchor bolts, as supplied by C/S.

3.3) Reposition the Frame and anchor the Frame to the slab with the C/S supplied anchor bolts following the manufacturer's guidelines.

3.4) Repeat the installation procedures for any additional lengths of Frame.

3.5) Apply grout in breakout on both sides of the expansion joint using an epoxy cement grout. The grout must be poured level with the breakout.

# STEP 4 (1"-12" JOINT)

## TURNBAR/CENTER PLATE INSTALLATION

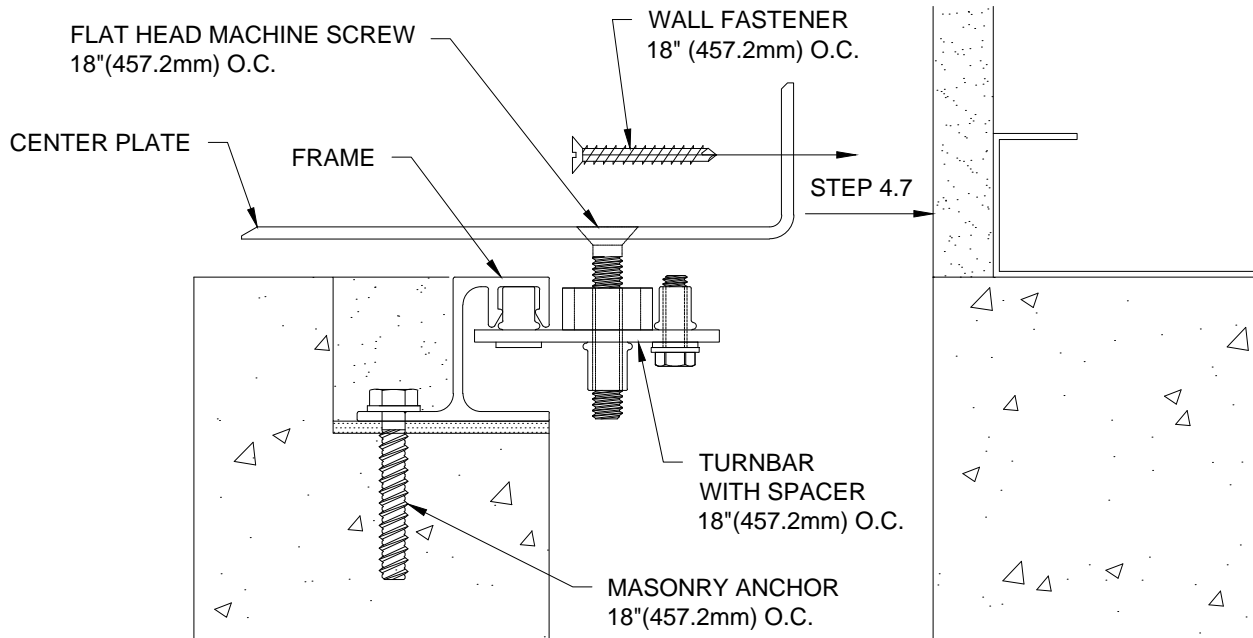

Notes: Install floor finish (if req'd) prior to installation of Center Plate. Turnbars are not required for 1" - 6" joints.

- 4.1) Prepare the Center Plate for installation by first cutting the Plate to length as needed.
- 4.2) Attach a Turnbar to the backside of the Center Plate at each hole location. (Note the orientation of the Turnbar in the detail above.) Thread a machine screw only approx. 1/4" into the Turnbar for now.
- 4.3) Leave a large enough gap between Wall Frame and wall in order to reach your hand behind and under Wall Frame Assembly.
- 4.4) Locate pivot pin of Turnbar into the pin receivers of the Frame.
- 4.5) Tighten the machine screw completely.
- 4.6) Repeat this procedure with the rest of the Turnbars. Note: All of the Turnbars should be angled in the same direction.
- 4.7) After Turnbar assembly is completed, slide the Wall Frame assembly flush with the wall.
- 4.8) Attach the Wall Frame to the wall using the C/S supplied wall fasteners.
- 4.9) Repeat this installation procedure for any additional lengths of the Wall Frame assembly.

# STEP 4a (13"-16" JOINT)

## TURNBAR/CENTER PLATE INSTALLATION

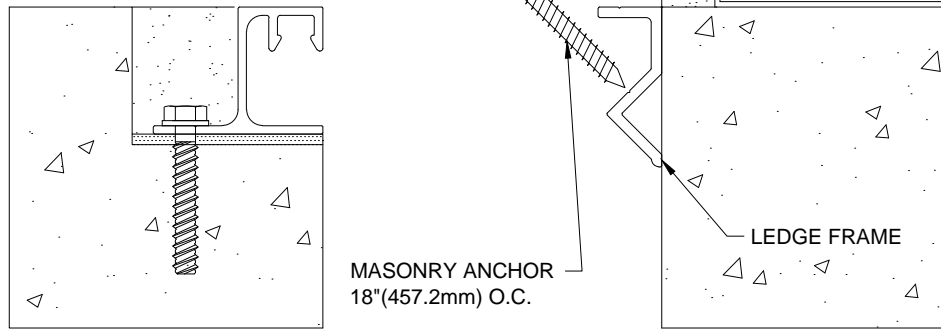

# STEP 4b (13"-16" JOINT)

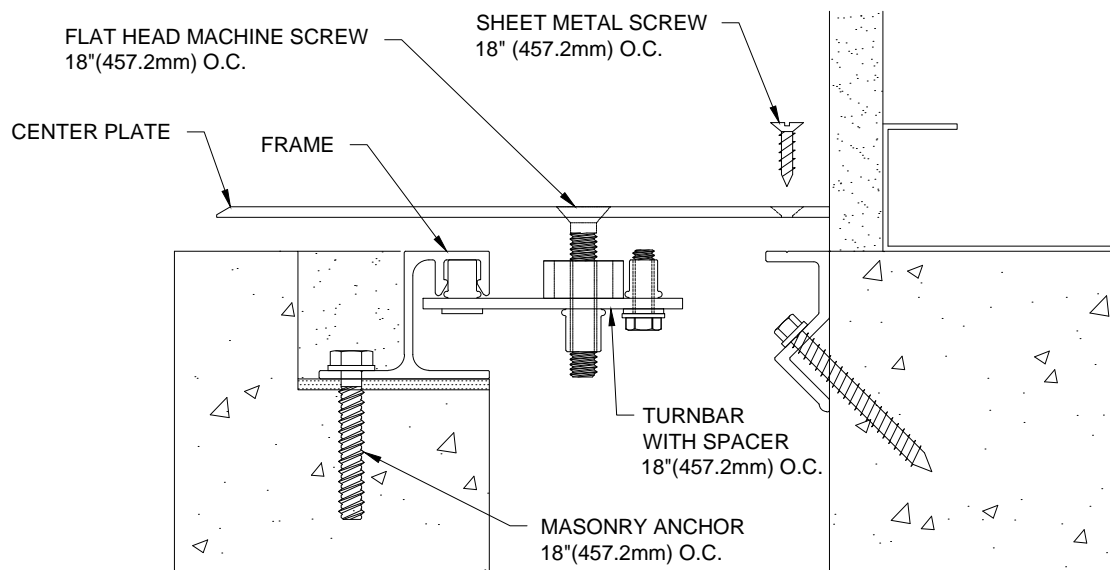

Notes: Install floor finish (if req'd) prior to installation of Center Plate. Turnbars are not required for 1" - 6" joints.

- 4.1) Cut the Ledge Frame to length as needed. Begin installation of Ledge Frame by installing frame against joint wall on wall side of joint. The Ledge Frame is to sit level to the blockout frame on the other side of the joint. The Ledge Frame should not sit above the top surface of the slab except to accommodate a floor finish.
- 4.2) Prepare the Center Plate for installation by first cutting the Plate to length as needed.
- 4.3) Attach a Turnbar to the backside of the Center Plate at each hole location. (Note the orientation of the Turnbar in the detail above.) Thread a machine screw only approx. 1/4" into the Turnbar for now.
- 4.4) Leave a large enough gap between Center Plate and wall in order to reach your hand behind and under the Plate.
- 4.5) Locate pivot pin of Turnbar into the pin receivers of the Frame.
- 4.6) Tighten the machine screw completely.
- 4.7) Repeat this procedure with the rest of the Turnbars. Note: All of the Turnbars should be angled in the same direction.
- 4.8) After Turnbar assembly is completed, slide the center plate back to the wall.
- 4.9) Attach the Center Plate to the Ledge Frame using the C/S supplied Sheet Metal Screws.
- 4.10) Repeat this installation procedure for any additional lengths of the Center Plate Assembly.

# STEP 5

COMPLETE INSTALLATION

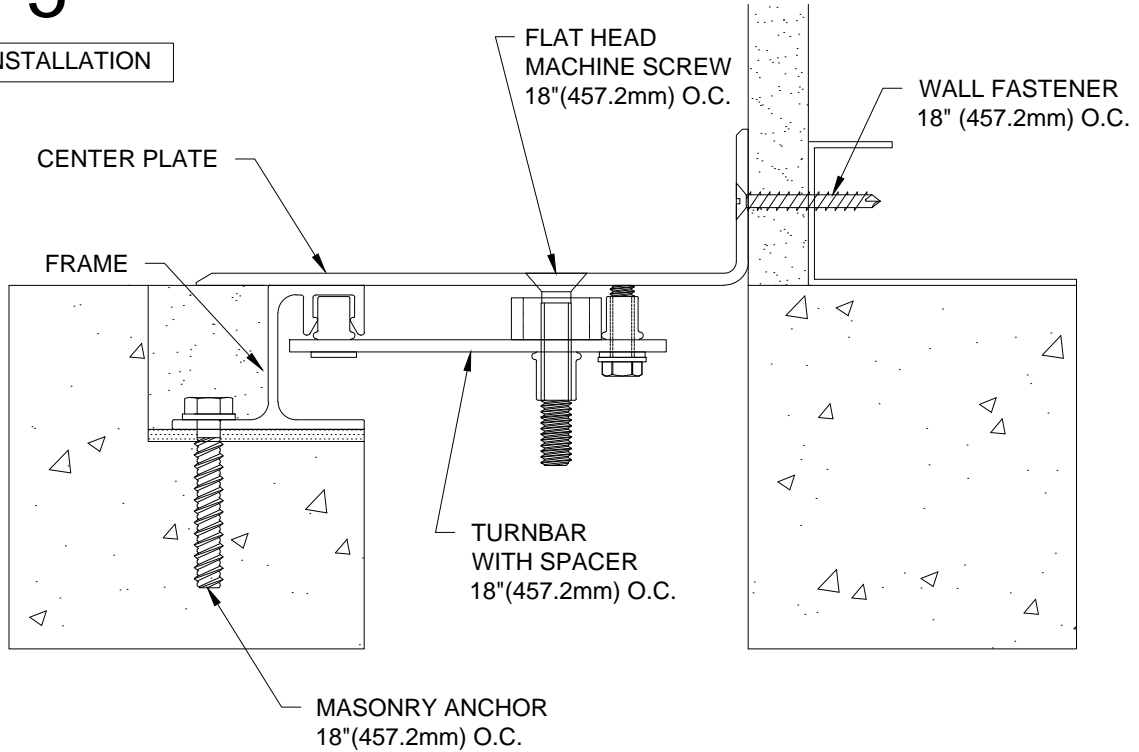

7"-12" FINAL ASSEMBLY

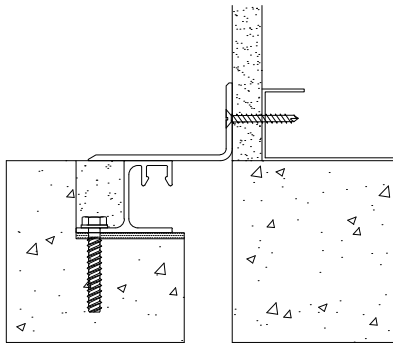

1" FINAL ASSEMBLY

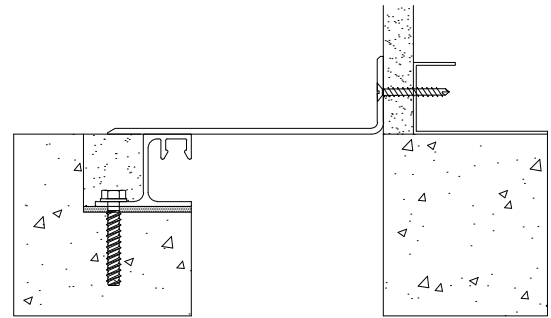

2" - 6" FINAL ASSEMBLY

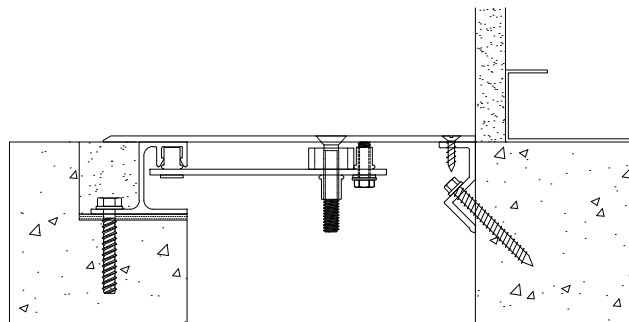

13" - 16" FINAL ASSEMBLY

- 5.1) When installation of the Joint Cover has been completed, remove all residue and foreign matter from the area and joint cover.
- 5.2) Clean the C/S Joint Cover and adjoining surfaces with proper cleaner.
- 5.3) Protect the Joint Cover until the Architect's final inspection.