

MODEL GTW-200 & GTWC-200 INSTALLATION INSTRUCTIONS

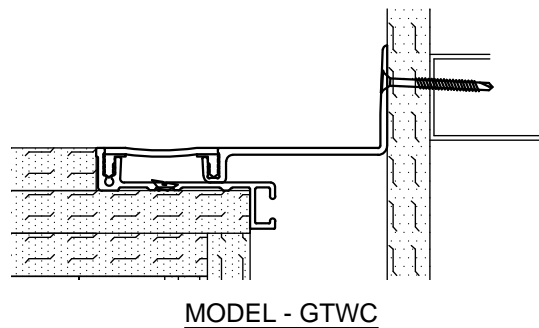
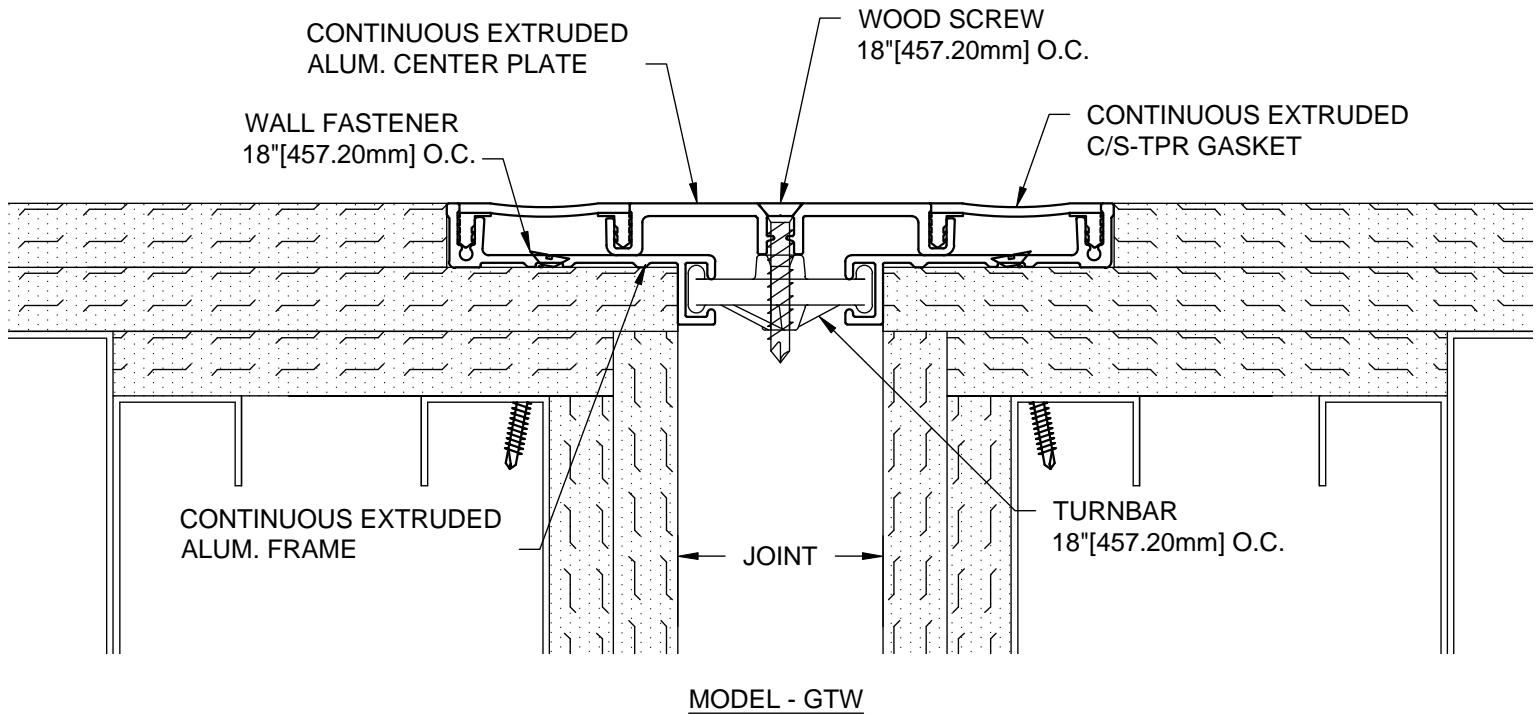

IMPORTANT INFORMATION

Prior to the commencement of Installation, all materials **MUST** be inspected for Damage. Any damage must be reported to CONSTRUCTION SPECIALTIES, INC., as soon as possible, so that replacement materials may be furnished without delay.

All work must be completed as per Architect's Approved "Shop Drawings", and in accordance with these Installation Instructions. When installation is complete, all materials must be protected from damage until the Architect's FINAL INSPECTION.

All materials should be arranged in the order that they are to be installed. All hardware required for each portion of the work should be placed with the appropriate materials.

Please review all Approved Shop Drawings and this Document to familiarize yourself with all the details and components of this assembly.

IMPORTANT:

READ THROUGH ALL INSTRUCTIONS PRIOR TO STARTING INSTALLATION

11/3/10



Construction Specialties™

6696 Route 405 Highway, Muncy PA 17756

This document is the property of Construction Specialties, Inc. and contains CONFIDENTIAL PROPRIETARY INFORMATION that is not to be disclosed to third parties and is not to be used without approval in writing from Construction Specialties, Inc.

Notes:

Before beginning installation, review the architectural drawings and approved Construction Specialties Inc. shop drawings to familiarize yourself with the joint cover models and locations.

Check all of the joint cover components to confirm that the correct joint cover model and size have been received. Also, check for materials that may have been damaged during shipping. Report all incorrect and/or damaged components to C/S at 800-233-8493.

Read through all the steps of these instructions prior to beginning work.

STEP 1

PREPARE BLOCKOUTS

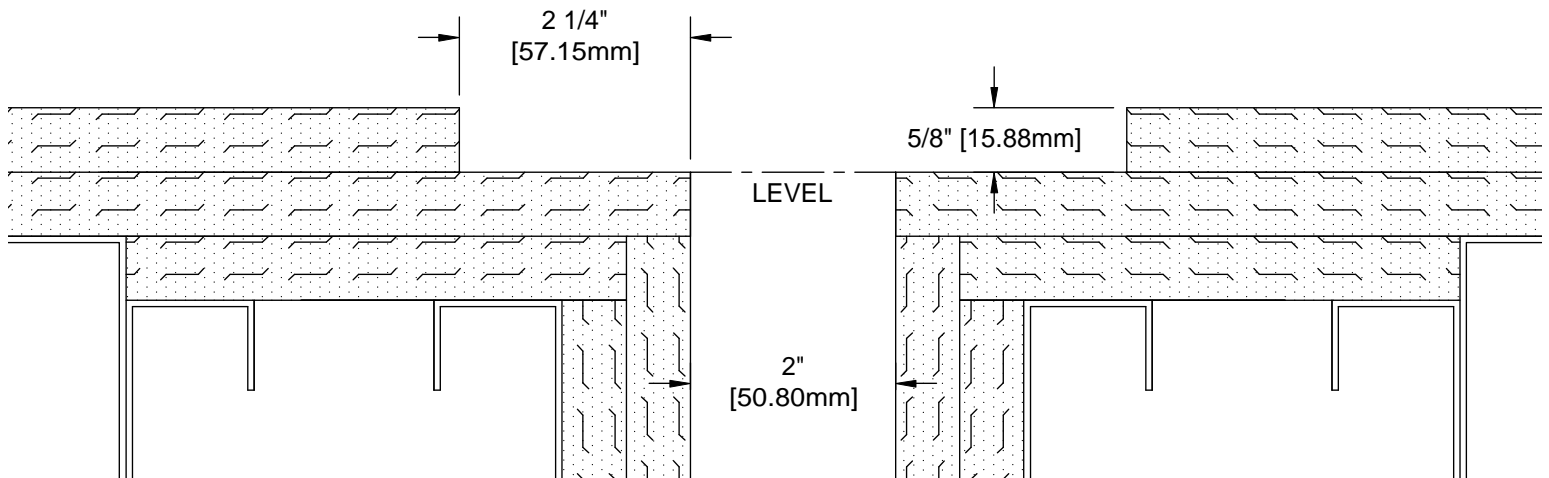

Step 1:

- 1.1) The blockouts must be prepared to receive the joint cover. (Note: The blockouts must be level across the width of the joint.)
- 1.2) Blockout depths will typically be 5/8"[15.88mm].

STEP 2

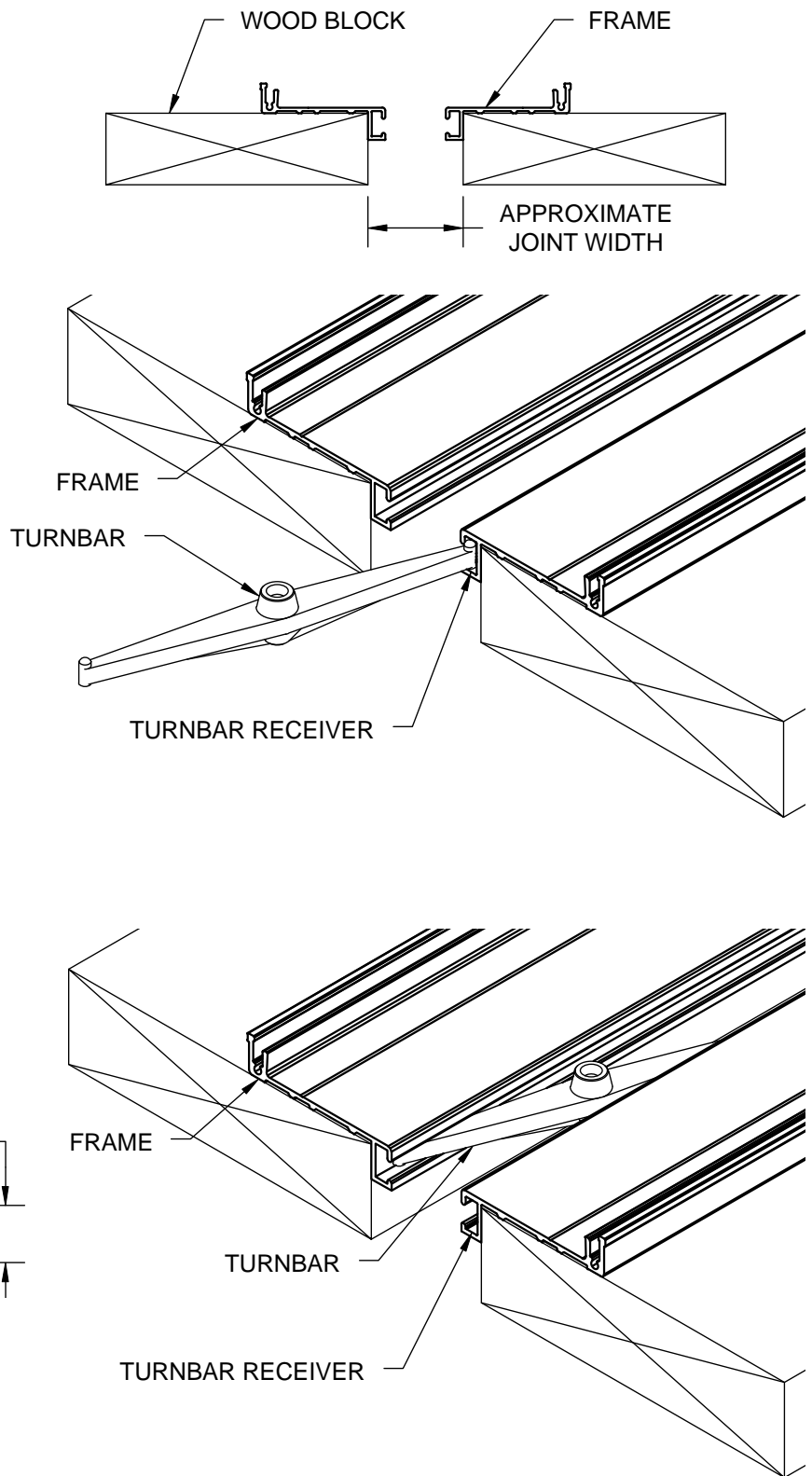
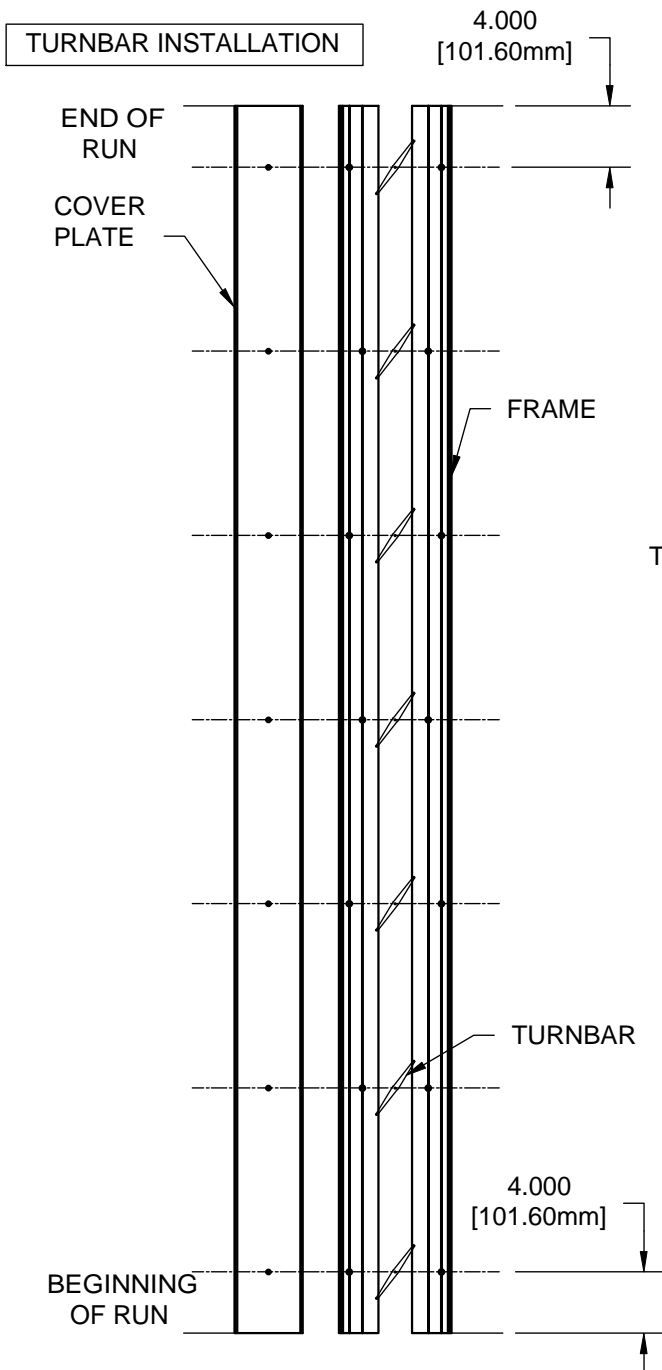

Step 2:

- 2.1) Begin installation of the Turnbars by determining the number of Turnbars needed for the length of the run.
- 2.2) Cut Frames to the required length needed for the run. Place the Frames on a set of wood blocking oriented approximately the same distance apart as your joint as shown in detail above.
- 2.3) Determine the location of the Turnbars (see detail above) and mark the location on the Frames with a pencil.
- 2.4) Slide the Turnbars into the Turnbar receivers of the Frames (see detail above) and position the Turnbars to the marked locations.

Notes: The orientation of the Turnbars should all be the same direction or the system will not function. Please note the orientation of the Turnbars in the details above (the side with the part number on it faces out). Model GTWC does not require any Turnbars.

STEP 3

GTW CENTER PLATE INSTALLATION

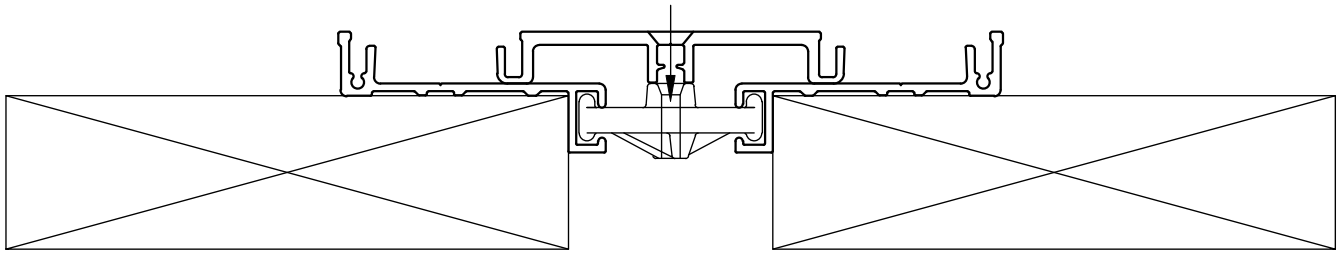

MODEL - GTW

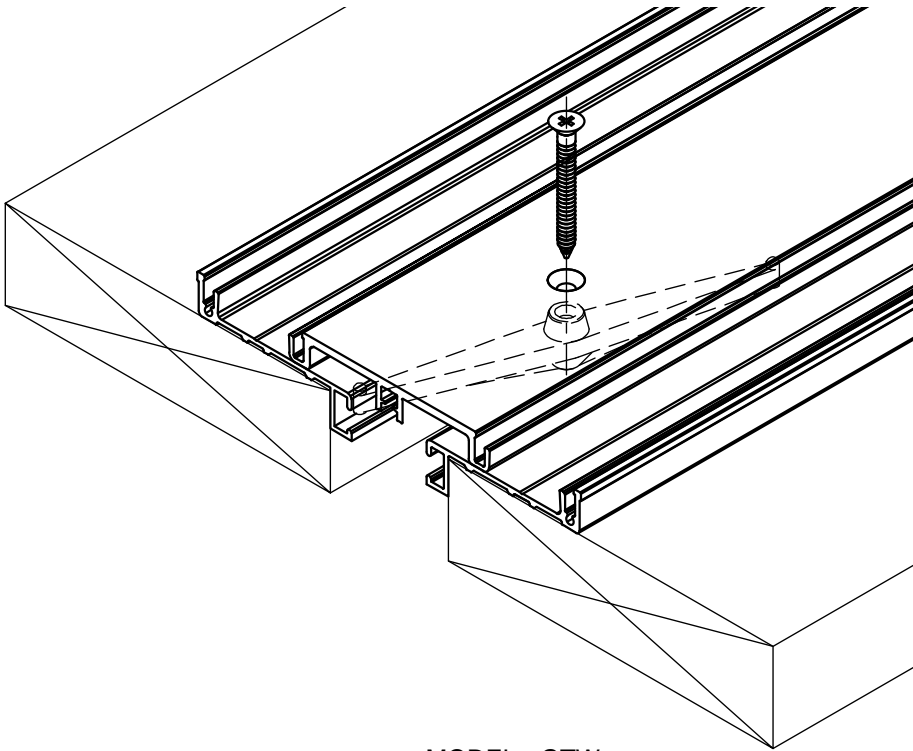

MODEL - GTW

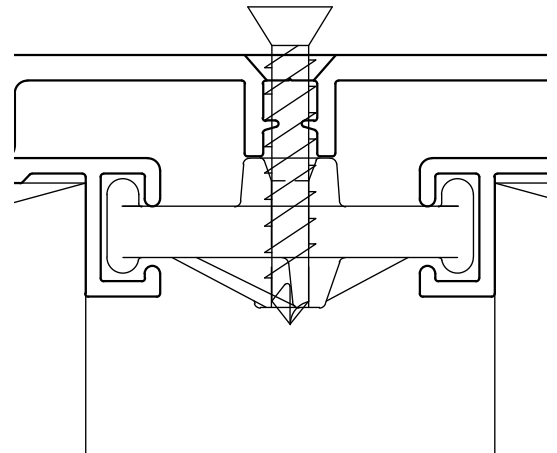

**DO NOT FULLY
TIGHTEN AT THIS TIME,
YOU WILL TIGHTEN AT
A LATER STEP.**

Step 3:

Note: IF YOU OVERTIGHTEN THE TURNBARS, THEY WILL SNAP. It is important to follow these instructions.

- 3.1) Begin installation of the Center Plate by first cutting a length of the Center Plate to the required length needed for the run.
- 3.2) Center the Plate over the joint/Frames. Make sure that the holes of the Center Plate and Turnbars are aligned.

Note: You can do this by shining a light in the holes if necessary and using a wire to line up the holes.

- 3.3) Using the C/S supplied wood screws attach the Center Plate to the Turnbars. DO NOT FULLY TIGHTEN.

Note: You will tighten the wood screws at a later step.

STEP 4

GTW FRAME INSTALLATION

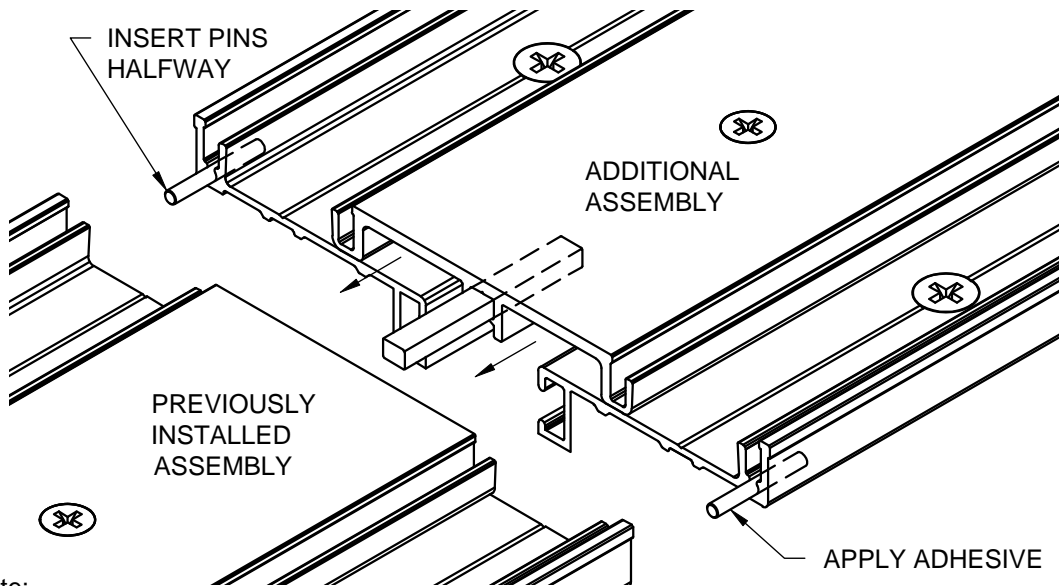
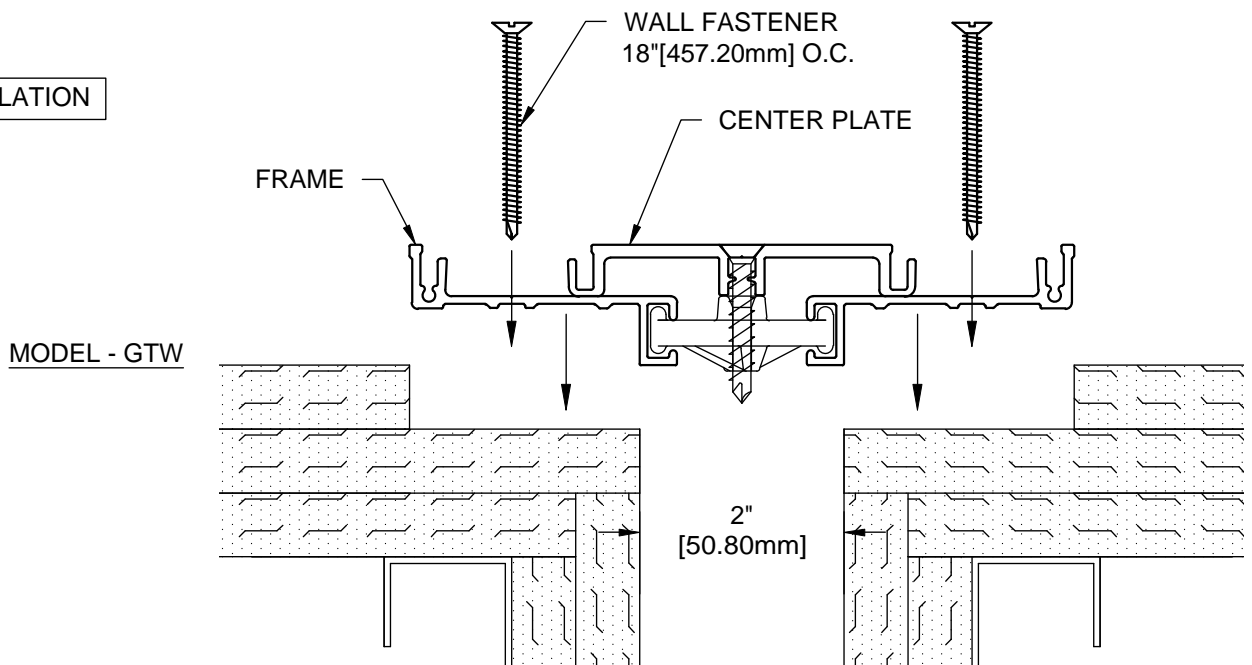

- Note:**
- If a C/S Fire Barrier is to be installed in the joint, please review the Fire Barrier Installation Instructions supplied, and if required install the Fire Barrier **BEFORE** installation of C/S Seismic Expansion Joint Aluminum Frames.
 - If a Waterstop is to be installed in the joint, please review the Waterstop Installation Instructions supplied, and if required install the Waterstop **BEFORE** installation of C/S Seismic Expansion Joint Aluminum Frames.
 - If there is an expected temperature change of 20°(+) daily, leave a 1/16" gap between Assemblies for 10' runs or an 1/8" gap between Assemblies for a 20' run due the thermal expansion of aluminum. Caulk (by others) in between Assemblies to seal gap.

Step 4:

- 4.1) Begin installation of the Frames by placing the partially assembled Expansion Joint Cover into the blockouts as shown in detail above. The Frames are to sit level, flat and parallel to the edge of the joint. Open to joint width.
- 4.2) Using the Frame as a template, drill the holes for the C/S supplied wall fasteners per manufacturer's guidelines.
- 4.3) Anchor the Frames to the wall with the C/S supplied wall fasteners following the manufacturer's guidelines.
- 4.4) Tighten the #12 Wood Screw until Screw Head is flush with top of Plate plus an additional 1/4 turn.
- 4.5) For additional lengths of Assembly, repeats steps 2 through 3 and insert Alignment Pin and Bar halfway into alignment slots of the next length of additional Assembly and if necessary apply instant adhesive to secure.
- 4.6) Align the loose Assembly with the previously installed Assembly and slide together. Make sure the alignment pins and bar slide into the slots of the previously installed Assembly (see detail above).
- 4.7) Repeat steps 4.1 through 4.4.

STEP 5

GTWC FRAME INSTALLATION

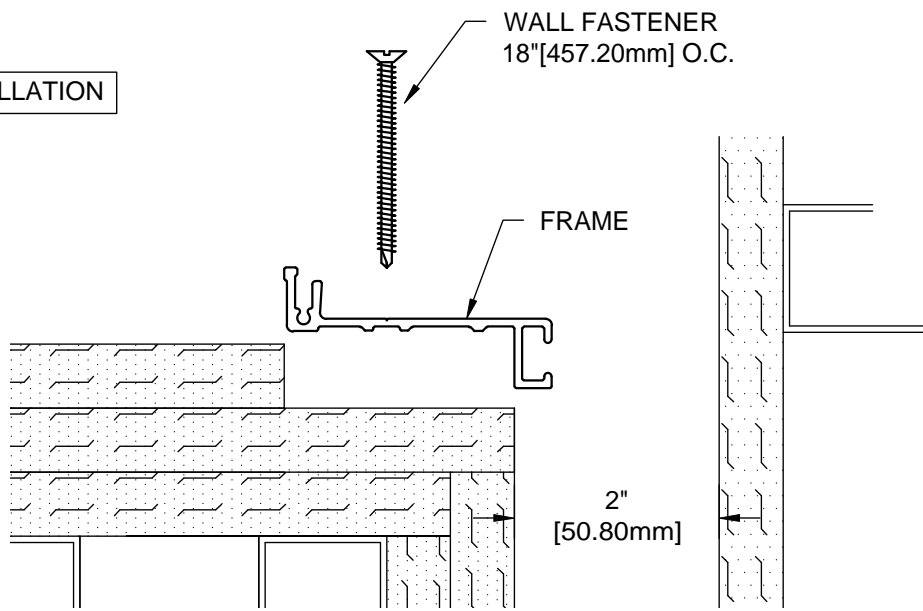

MODEL - GTWC

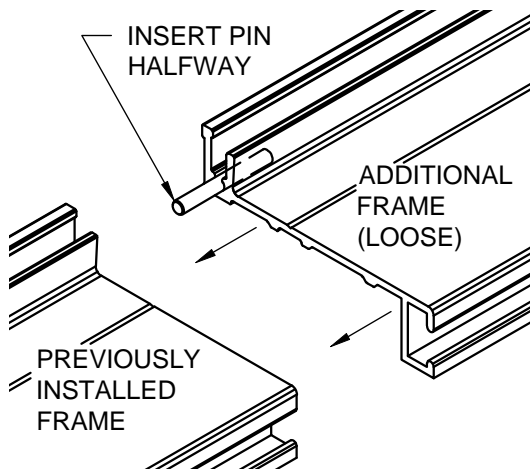

- Note:**
- If a C/S Fire Barrier is to be installed in the joint, please review the Fire Barrier Installation Instructions supplied, and if required install the Fire Barrier **BEFORE** installation of C/S Seismic Expansion Joint Aluminum Frames.
 - If a Vapor Barrier/Waterstop is to be installed in the joint, please review the Vapor Barrier/Waterstop Installation Instructions supplied, and if required install the Vapor Barrier/Waterstop **BEFORE** installation of C/S Seismic Expansion Joint Aluminum Frames.
 - If there is an expected temperature change of 20°F(+) daily, leave a 1/16" gap between Frames for 10' runs or an 1/8" gap between Frames for a 20' run due the thermal expansion of aluminum. Caulk in between Frames to seal gap.

Step 5:

- 5.1) Begin installation of the Frames by placing a length of Frame into the blockout. Cut the Frame to length as needed. The Frame is to sit level, flat and parallel to the edge of the joint.
- 5.2) Using the Frame as a template, drill holes for the C/S supplied anchor bolts per manufacturer's guidelines.
- 5.3) Anchor the Frame to the slab using the C/S supplied anchor bolts following the manufacturer's guidelines.
- 5.4) Repeat this installation procedure for any additional lengths of Frame.
- 5.5) For additional lengths of Frame, insert Alignment Pin halfway into alignment slots of Additional Frame (loose) if necessary, apply instant adhesive (by others) to secure the Pin.
- 5.6) Align the loose Frame with the previously installed Frame and slide together. Make sure the Alignment Pins slide into the slots of the previously installed Frame.

STEP 6

GTWC PLATE INSTALLATION

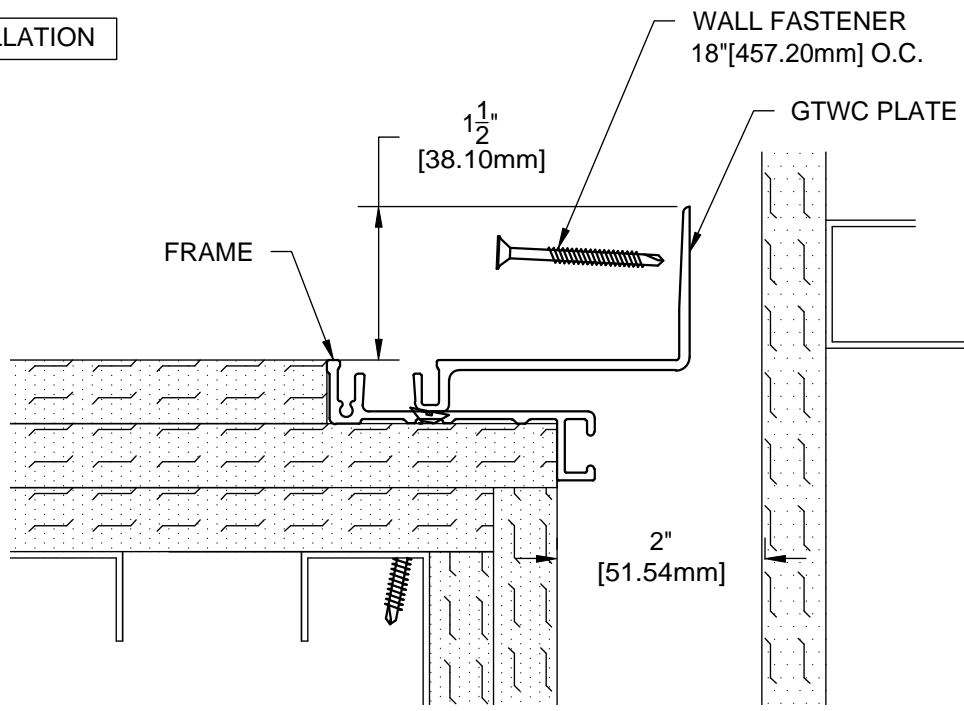

MODEL - GTWC

Step 6:

Note: Turnbars are not required for Model GTWC.

-If there is an expected temperature change of 20°F(+) daily, leave a 1/16" gap between Plates for 10' runs or an 1/8" gap between Plates for a 20' run due the thermal expansion of aluminum. Caulk in between Plates to seal gap.

- 6.1) Begin installation of the GTWC Plate by first placing a length of the Center Plate beside the joint and cutting required length.
- 6.2) Measure 1 1/2"[38.10mm] above slab surface and mark a line on the wall surface.
- 6.3) Align the top of the vertical flange of the Center Plate with the line.
- 6.4) Using the Center Plate as a template, mark and drill the location for the C/S supplied wall fasteners.
- 6.5) Attached the Center Plate using the C/S supplied wall fasteners in accordance with the manufacturer's guidelines.
- 6.6) Repeat these installation instructions for any additional lengths of Center Plate.

STEP 7

GASKET INSTALLATION

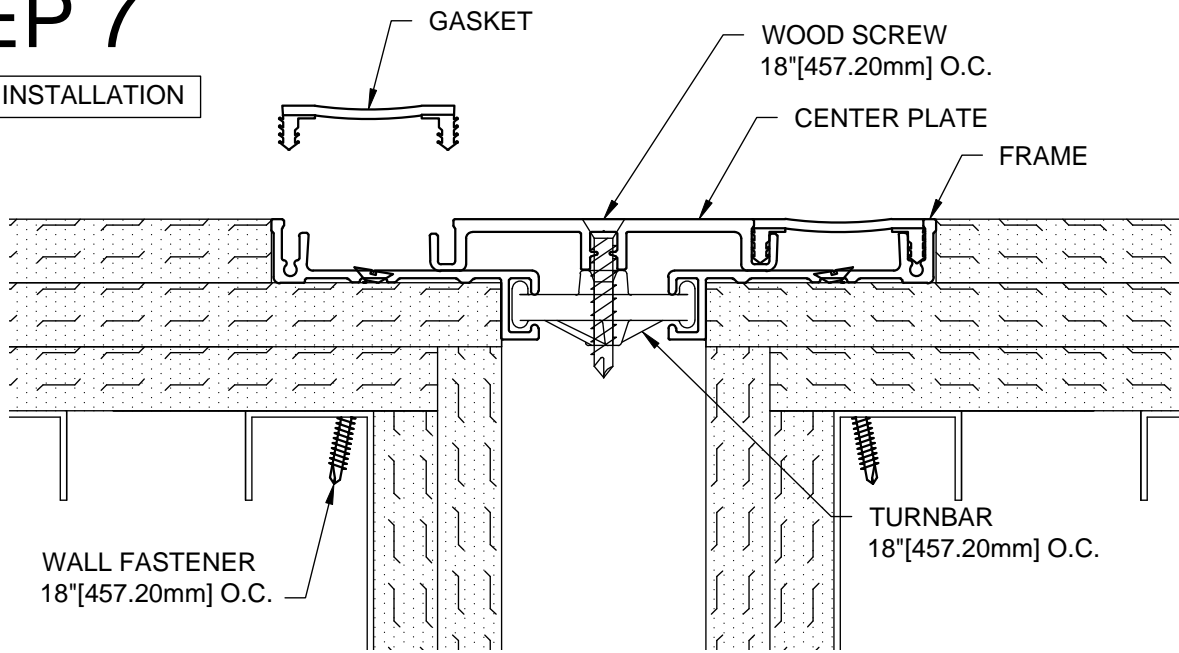

MODEL - GTW

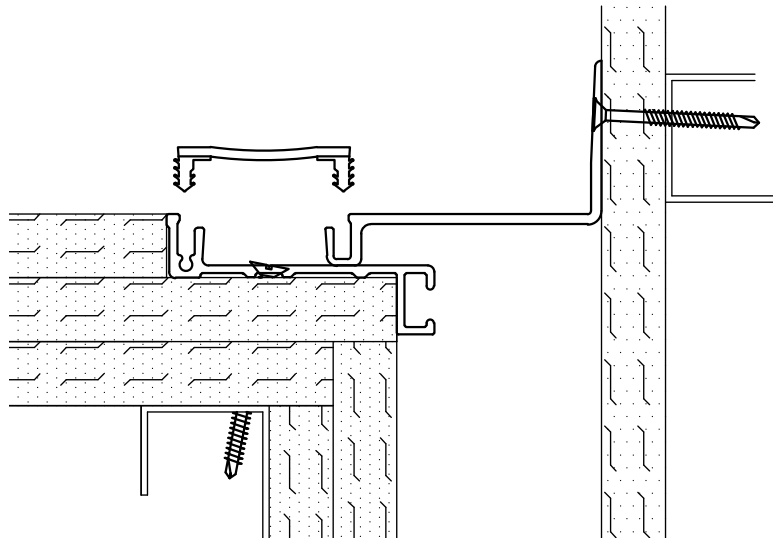

MODEL - GTWC

Step 7:

- 7.1) Complete the installation by inserting the Gaskets. It may be necessary to drive the Gasket in place using a rubber mallet and a wood block. Lubricating the push in areas by spraying them with a light mist of water will also ease the installation. When Gaskets are properly installed, they should be flush with the top surface of the Center Plate and Frames.

STEP 8

COMPLETE INSTALLATION

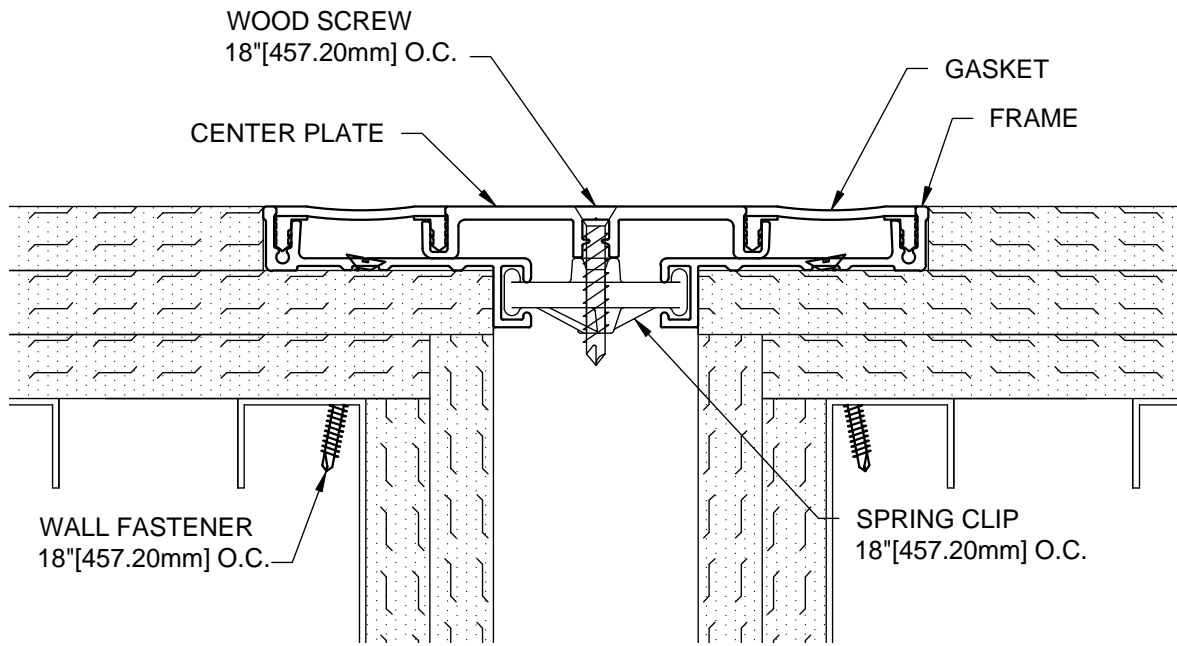

MODEL - GTW

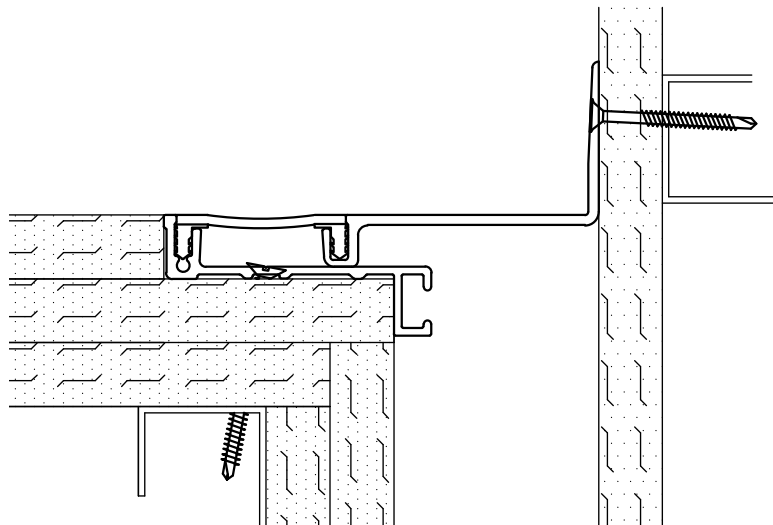

MODEL - GTWC

Step 8:

- 8.1) When installation of the C/S Wall Expansion Joint Cover has been completed, remove all residue and foreign matter from the area and joint cover.
- 8.2) Clean the C/S Joint Cover and adjoining surfaces with a cleaner that is adequate for surface.
- 8.3) Protect the Joint Cover until the Architect's final inspection.