

MODELS SSR-1101 THRU SSR-3001 INSTALLATION INSTRUCTIONS

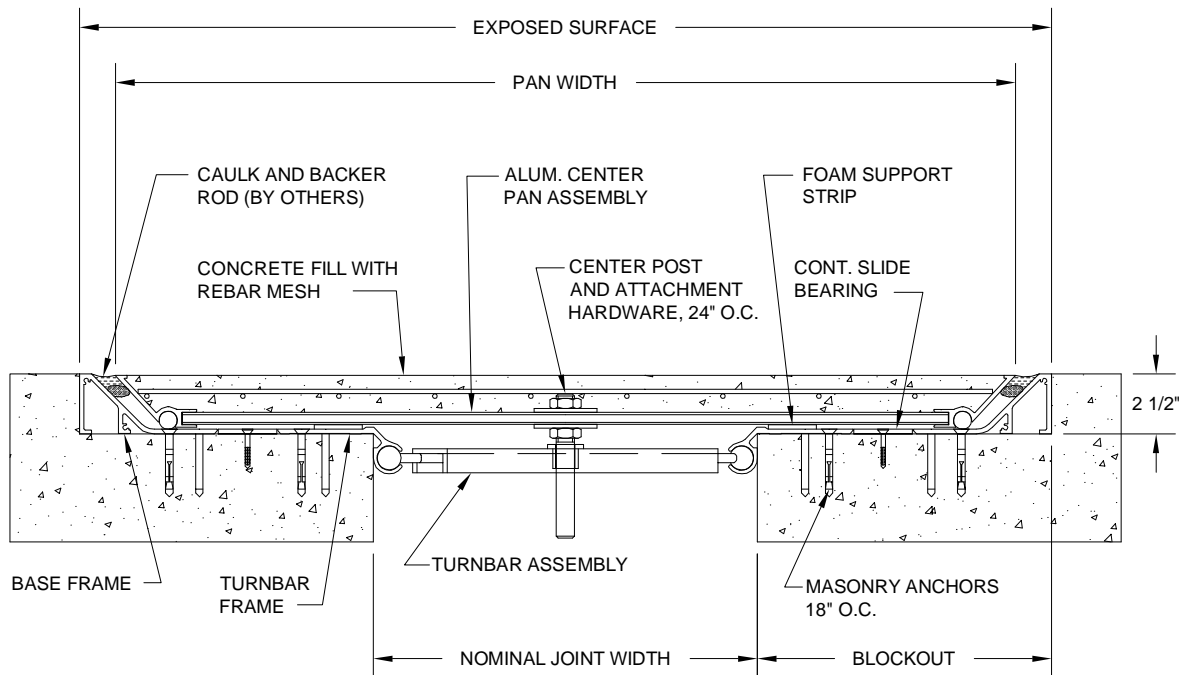

IMPORTANT INFORMATION

Prior to the commencement of Installation, all materials **MUST** be inspected for Damage. Any damage must be reported to CONSTRUCTION SPECIALTIES, INC., as soon as possible, so that replacement materials may be furnished without delay.

All work must be completed as per Architect's Approved "Shop Drawings", and in accordance with these Installation Instructions. When installation is complete, all materials must be protected from damage until the Architect's FINAL INSPECTION.

All materials should be arranged in the order that they are to be installed. All hardware required for each portion of the work should be placed with the appropriate materials.

Please review all Approved Shop Drawings and this Document to familiarize yourself with all the details and components of this assembly.

IMPORTANT:
READ THROUGH ALL INSTRUCTIONS PRIOR TO STARTING INSTALLATION

10/6/08

CONSTRUCTION SPECIALTIES, INC.
P.O. BOX 380
MUNCY, PA 17756
PHONE: (570)546-5941 FAX: (570)546-8022

This document is the property of Construction Specialties, Inc. and contains CONFIDENTIAL PROPRIETARY INFORMATION that is not to be disclosed to third parties and is not to be used without approval in writing from Construction Specialties, Inc.

GENERAL NOTES

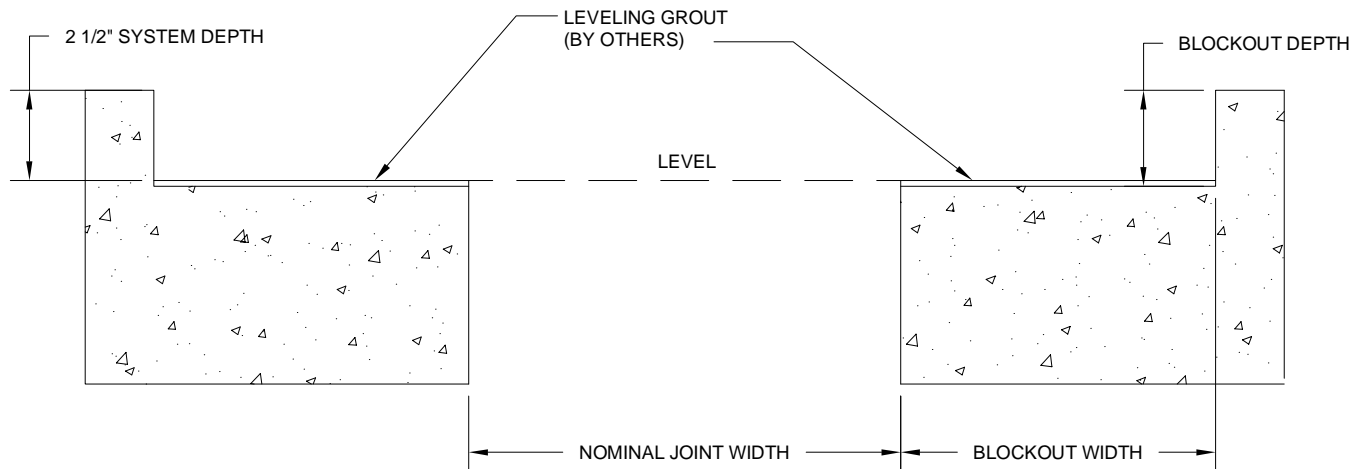

- 1) Before beginning installation of these joint covers, review the layouts for the various runs of joint cover as detailed on the approved C/S shop drawings.
- 2) The "SSR" series joint covers must be securely mounted to structurally sound substrates. Repair all cracks or spawled areas of the concrete in the blockouts and in the deck adjacent to the blockout.
- 3) The blockouts in which the covers are to be mounted must be **flat, level and parallel**. The blockout depth should be made deeper than the actual system depth and self-leveling grout should be used to set the final depth, and to provide a smooth, flat finish. **The base of the blockout must be flat (along the length of the joint) to within +/-1/16" and level (across the joint) to within +/-1/16"**.
- 4) The blockout width shown on the C/S shop drawings is a minimum width dimension. The blockout may be made wider to allow for greater installation tolerance.
- 5) The surface of the blockouts must be clean and free from any loose dust, dirt, debris and oils that would affect the installation of the covers.
- 6) It is possible that the expansion/seismic joint may have experienced some amount of movement at the time of installation. For proper installation of the "SSR" covers, the joint width **must be within +/-1/4" of nominal**. If the joint width at the time of installation is not within this tolerance, please contact the factory as some adjustments to the key installation dimensions may be required. These instructions assume that the nominal joint is within tolerance.
- 7) Coordinate installation of cover with installation of fire barrier systems and vapor barrier membrane when required.

IMPORTANT: Concrete will curl the center-plate of this system unless you take proper measures to prevent it.

Selection of the proper concrete mix is essential. Talk to your local Concrete supply Engineer and discuss this special application and get their recommendation(s) for the mix that will prevent excessive curling of the center-plate/pan. (They know concrete, your local practices and weather conditions.)

Their recommendations may include a low water-to-cement ratio; changing the aggregate, adjusting the cement-to-fly ash ratio; longer cure time; controlling shrinkage with an admixture; moist curing, ect.

All such recommendations should be coordinated with the Architect to ensure the integrity of the specification is maintained.

EXTERIOR INSTALLATION of this expansion joint cover system requires yet more care and in addition to any/all of the above possible recommendations from your Concrete Engineer, moist curing has been found to be essential to a successful installation.

STEP 1

BEGIN BASE FRAME INSTALLATION



Note: Proper installation of the "SSR" covers is dependent upon the proper location of the Base Frames. For the Pan Assembly to fit and function properly between the Frames, the Frames must be anchored parallel to the joint and to one another. They must be located at the proper distance from the edge of the joint and the exposed surface dimension must be maintained within a tolerance of $\pm 1/8$ ". The exposed surface must also be centered over the joint to within $\pm 1/8$ ".

The Frame Location (or minimum blockout) and Exposed Surface and Joint Width dimensions are shown on the C/S shop drawings.

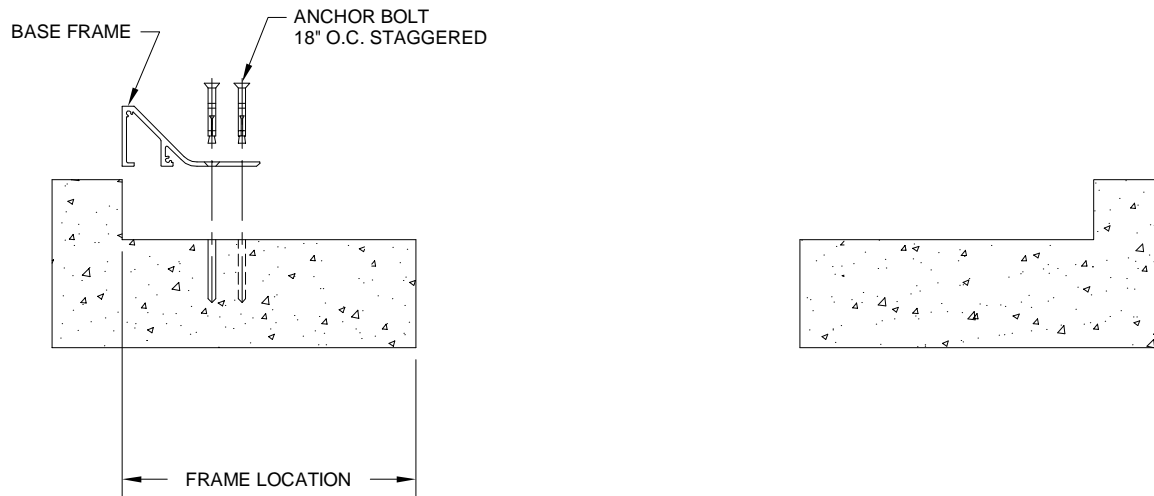

1.1) In the blockout on one side of the joint, measure the bottom of the blockout for the Frame Location Dimension. If the blockout has been made wider than the minimum, mark the bottom of the blockout and strike a chalk line at this location. The chalk line should extend along the full length of the run.

1.2) Beginning near the center of the run and working towards each end, position the first length of Base Frame against the back of the blockout or along the Frame Location line.

1.3) Using the Frame as a template, drill the holes for the C/S supplied anchor bolts. (Follow the drilling instructions provided by the anchor bolt manufacturer.)

1.4) Remove the Frame and clean the holes. Reposition the Frame and anchor the Frame into the blockout with the C/S supplied anchors. (Follow the anchor bolt manufacturer's installation instructions.)

STEP 2

CONTINUE BASE FRAME INSTALLATION

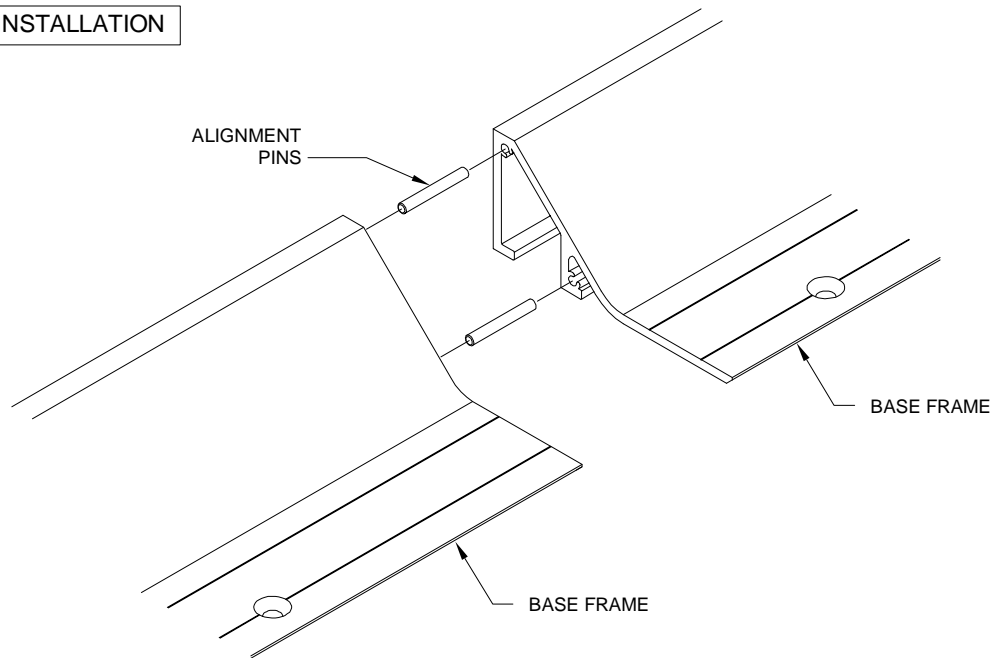

Note: To assist in maintaining the alignment of the exposed top edge of Base Frames, alignment pins are to be placed in the Frame sections prior to installation.

2.1) Place one of the alignment pins into each of the extrusion bosses of the next length of Base Frame. Insert the pin approximately 1/2 of its length.

2.2) Peen one leg of the extrusion boss to hold the pin in position.

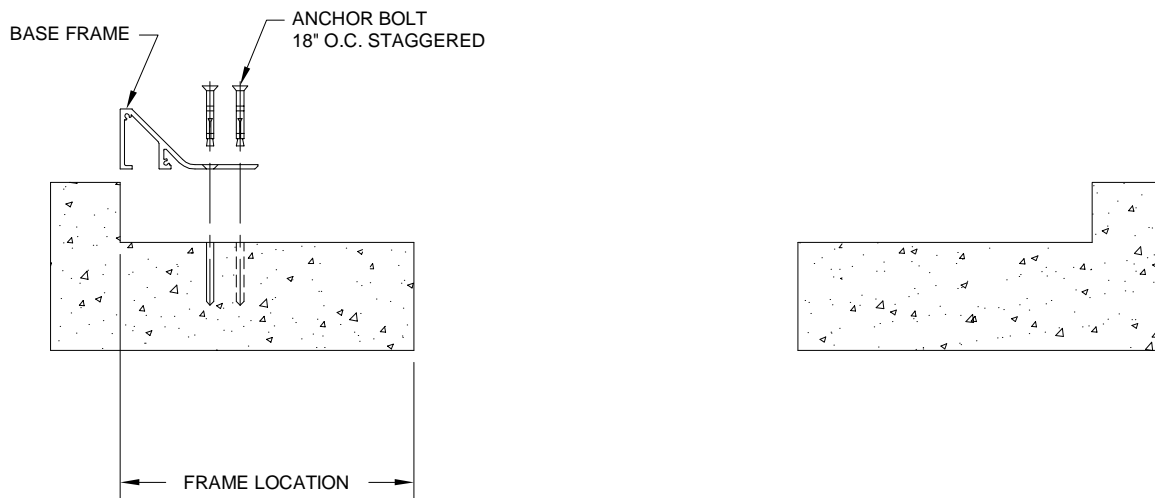

2.3) Position the adjacent lengths of Frame into the blockout and insert the alignment pins into the extrusion bosses of the previous Frame.

2.4) Following the instruction from Step 1, position, drill and anchor each additional length of Base Frame for this side of the joint.

Note: As you approach each end of the run, the last lengths of Frame may have to be cut to the appropriate length.

STEP 3

INSTALL OPPOSITE BASE FRAME

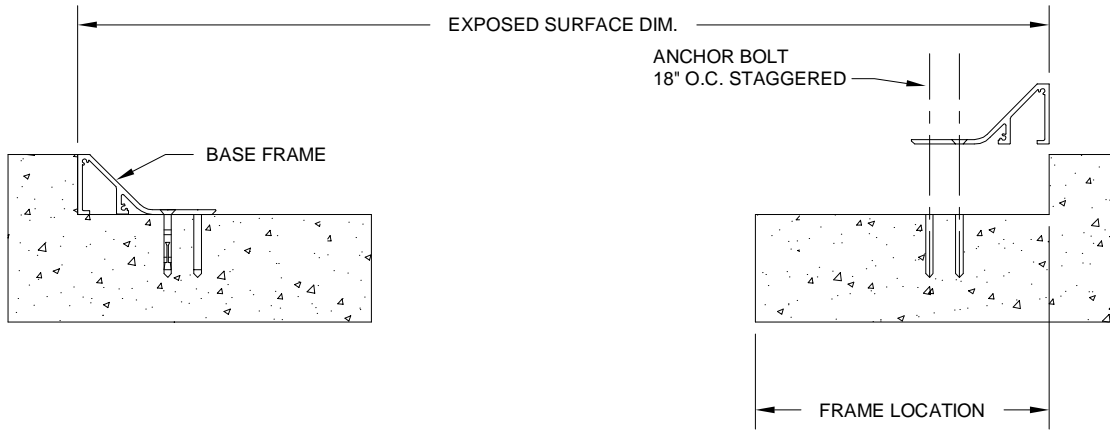

- 3.1) Beginning again near the center of the run and working towards each end, position the first length of Base Frame in the opposite blockout.
- 3.2) Align the Frame with the back of the blockout or with the location line. Measure off the top edge of the initial anchored length of Base Frame to confirm that the exposed surface dimension is maintained and is within tolerance. Also, make certain that the Frame is equal distance or parallel to the initial Frame, over the full length.
- 3.3) Using the Frame as a template, drill the holes for the C/S supplied anchor bolts. (Follow the drilling instructions provided by the anchor bolt manufacturer.)
- 3.4) Remove the Frame and clean the holes. Reposition the Frame and anchor the Frame into the blockout with the C/S supplied anchors. (Follow the anchor bolt manufacturer's installation instructions.)
- 3.5) Insert alignment pins into the next length of Frame and position it into the blockout.
- 3.6) Again, position the Frame parallel to the Frame in the opposite blockout and anchor according to the previous instructions.
- 3.7) Repeat and install the remaining Frames for the entire length of the run.

STEP 4

BEGIN INSTALLATION OF TURNBAR FRAMES

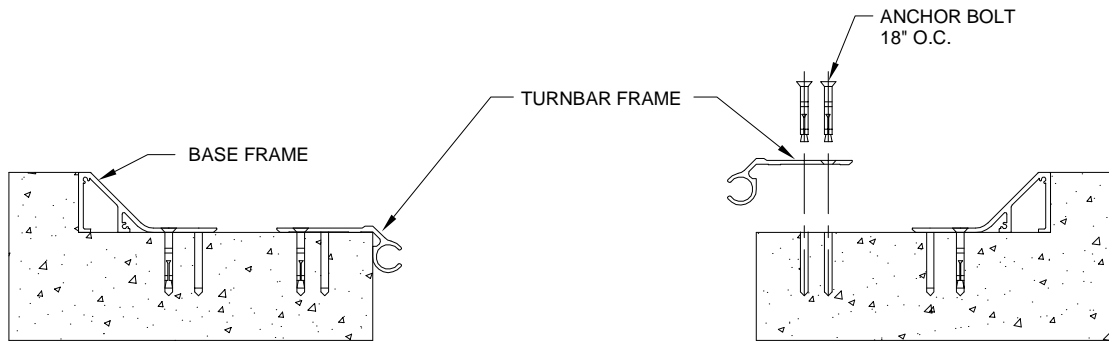

Note: The Turnbar Frames are to be located so that they nest over the corner of the slab. Due to irregularities in the edge of the slab, the Turnbar Frame may cantilever out from the face of the slab by up to 1/4".

4.1) Beginning again near the center of the run and working towards each end, position the first length of Turnbar Frame on the corner of the slab.

4.2) Using the Frame as a template, drill the holes for the C/S supplied anchor bolts. (Follow the drilling instructions provided by the anchor bolt manufacturer.)

4.3) Remove the Frame and clean the holes. Reposition the Frame and anchor the Frame into the blockout with the C/S supplied anchors. (Follow the anchor bolt manufacturer's installation instructions.)

4.4) Position, drill and install the Turnbar Frame at the opposite side of the joint. (Note: It is recommended that the Turnbar Frames be installed in pairs, one at each side of the joint, to facilitate installation of the Turnbar Assemblies as indicated in Step 5.)

STEP 5

BEGIN TO INSTALL TURNBARS

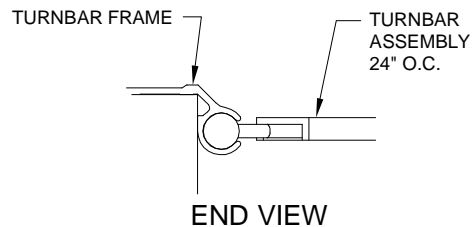
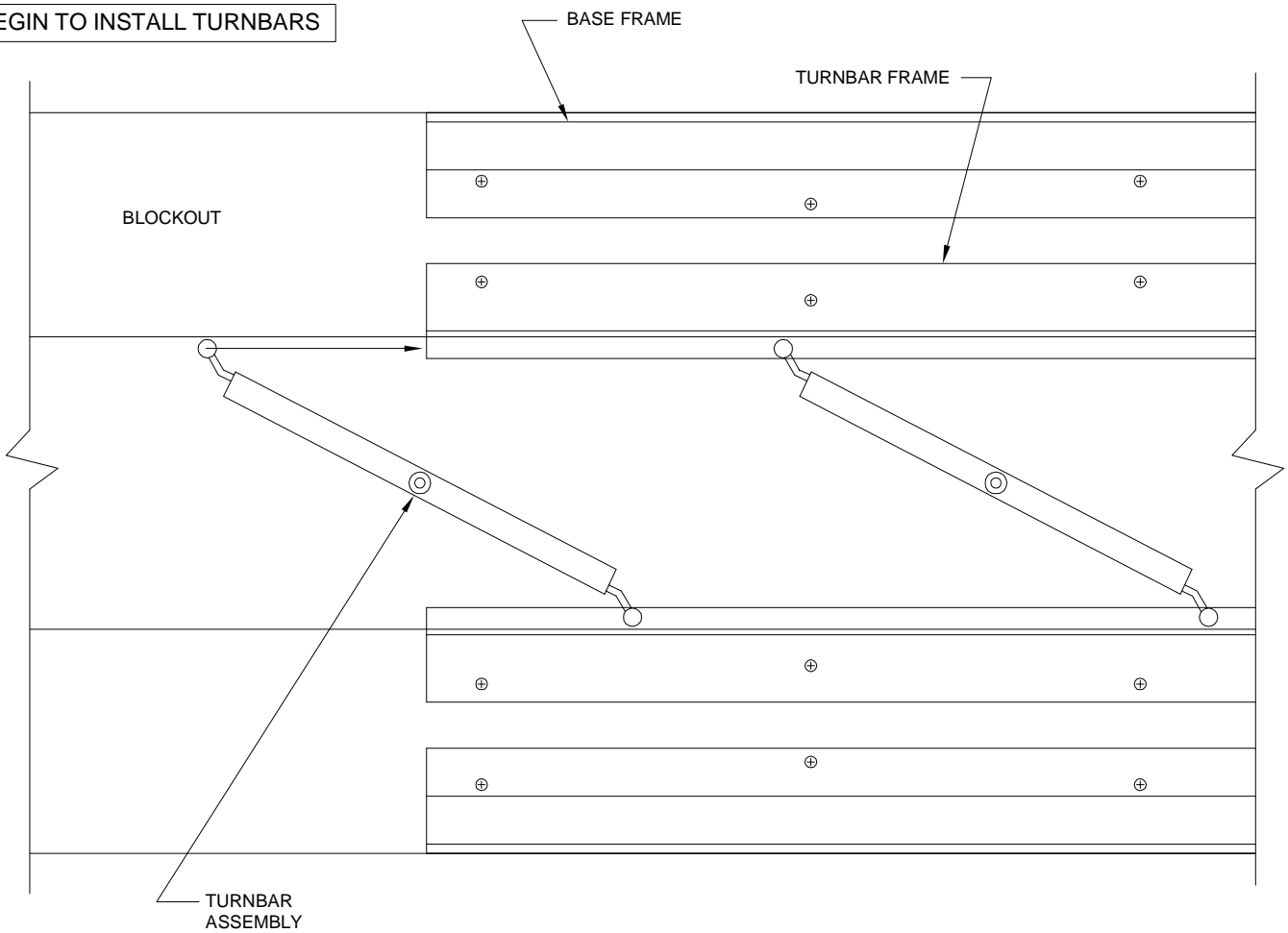

Note: The spacing and quantity of the Turnbar Assemblies varies with joint size. Refer to the approved shop drawings for the appropriate Turnbar spacing.

5.1) With the first pair of Turnbar Frames installed, insert the first Turnbar Assembly into the Frames. Note the orientation of the Turnbars as shown in the detail above. The bent angle of the ball pins are to face outward, towards the Frames, so that the channel does not contact the Frames. The wide, flat portion of the channel should be up with the short legs facing down.

5.2) Place the ball, at one end of the assembly, into the appropriate Turnbar Frame and slide inward until the ball at the opposite end can be inserted into the opposite Turnbar Frame.

5.3) Repeat the inserting procedure for the remaining number of bars as required for the length of Frame.

5.4) Continue with installation of the adjacent lengths of Turnbar Frame, inserting the Turnbar Assemblies with each pair as they are installed.

Note: At an end condition, the Turnbars may have to be inserted before the final length of Frame is anchored.

STEP 6

INSTALLING SLIDE BEARINGS

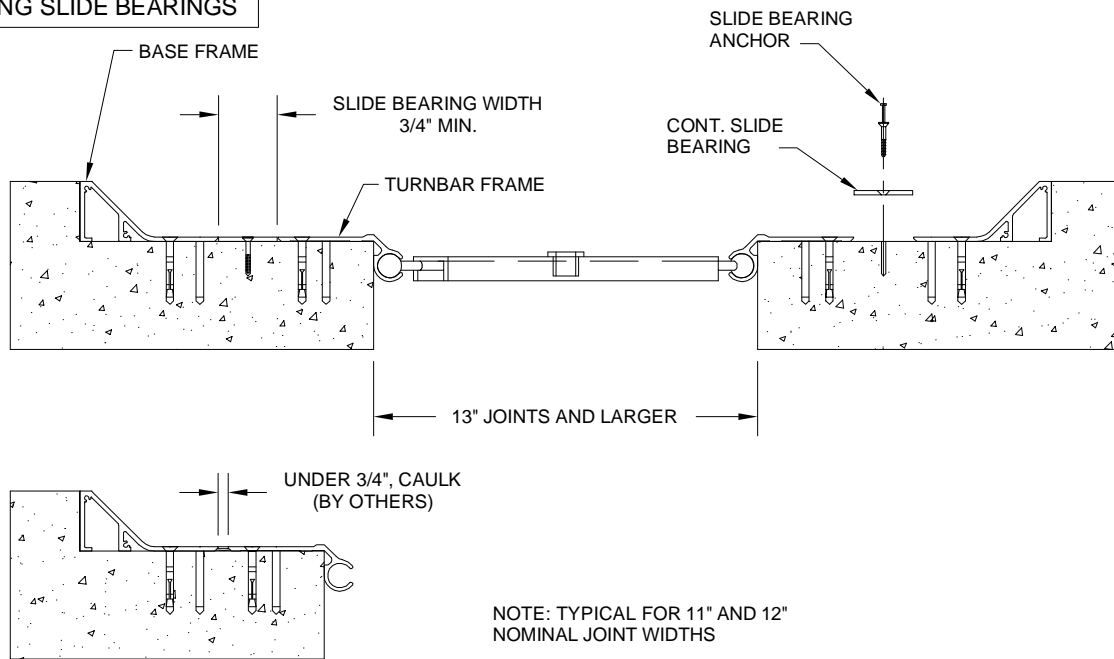

Note: The continuous slide bearings are used to prevent the pan bearings from dropping into the space between Frames during seismic movement causing damage. When the space between Frames is less than 3/4" wide, the space is to be filled level with caulking (by others). At larger joints, 3" wide strips are to be placed at 18" o.c.

- 6.1) Position the first length of continuous slide bearing into the space between the Base Frame and Turnbar Frame.
- 6.2) Using the slide bearing as a template, mark the hole locations for the bearing anchors, then remove the slide bearing.
- 6.3) Drill the holes for the appropriate C/S supplied anchors. (Drill the holes per the anchor manufacturer's instructions.)
- 6.4) Place the slide bearing back into position and anchor to the slab.
- 6.5) Repeat for the remaining slide bearing lengths that are required for each side of the joint.

INSTALLING FOAM SUPPORT STRIPS

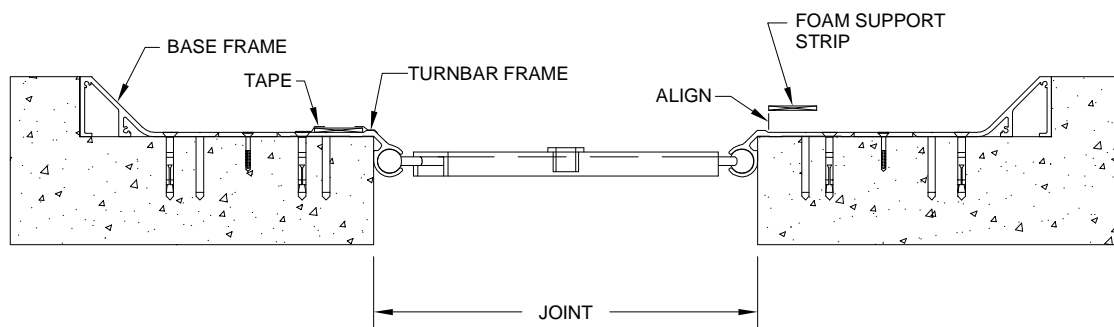

Note: Foam support strips are 1 1/2" wide by 3/16" thick strips of styrofoam that have been provided by C/S. These strips are to be placed on top of the Turnbar Frames continuously along the full length of the run. These strips will support the underside of the center pans to prevent bowing of the Pan as the concrete is poured.

- 6.6) Position the lengths of continuous foam support strip so the inside edge aligns with the raised portion of the Turnbar Frame.
- 6.7) Use several short lengths of duct tape to hold each strip in place.
- 6.4) Place strips along each side of the joint, for the full length of the run.

STEP 7

CENTER PAN ASSEMBLY AND INSTALLATION

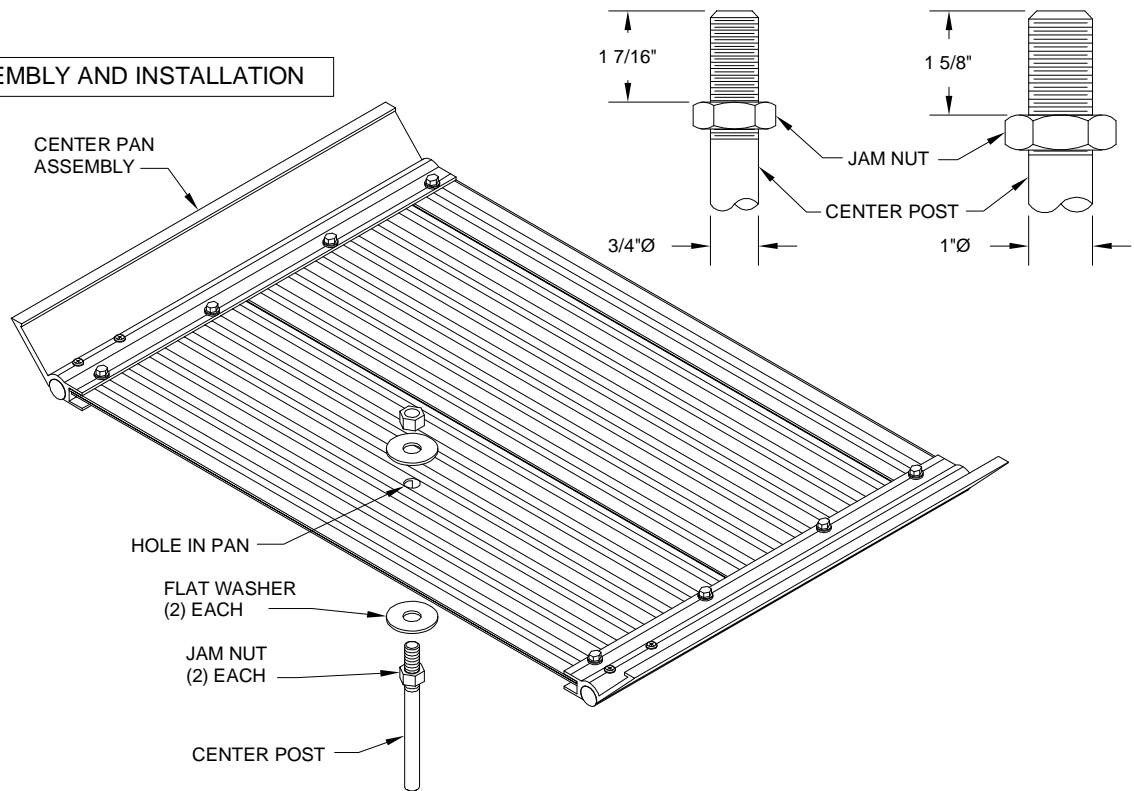

Note: Center Pan Assemblies are supplied in typical 10'-0" lengths. Each Pan is to receive 3/4"Ø or 1"Ø Center Post Assemblies. The quantity and diameter of the Center Posts is dependent upon the joint width. The size and quantity will be indicated on the C/S shop drawings. The holes for the center posts will be located and drilled in the factory.

- 7.1) Place a jam nut onto each Center Post and thread on until the nut is the appropriate distance from the end. See details above.
- 7.2) Place a large diameter flat washer over the jam nut and insert the threaded end of the Center Post up through the hole from the underside of the Pan.
- 7.3) From the top side of the Pan, place a large diameter flat washer and jam nut onto the Center Post.
- 7.4) Tighten the jam nut against the Pan and flat washer.

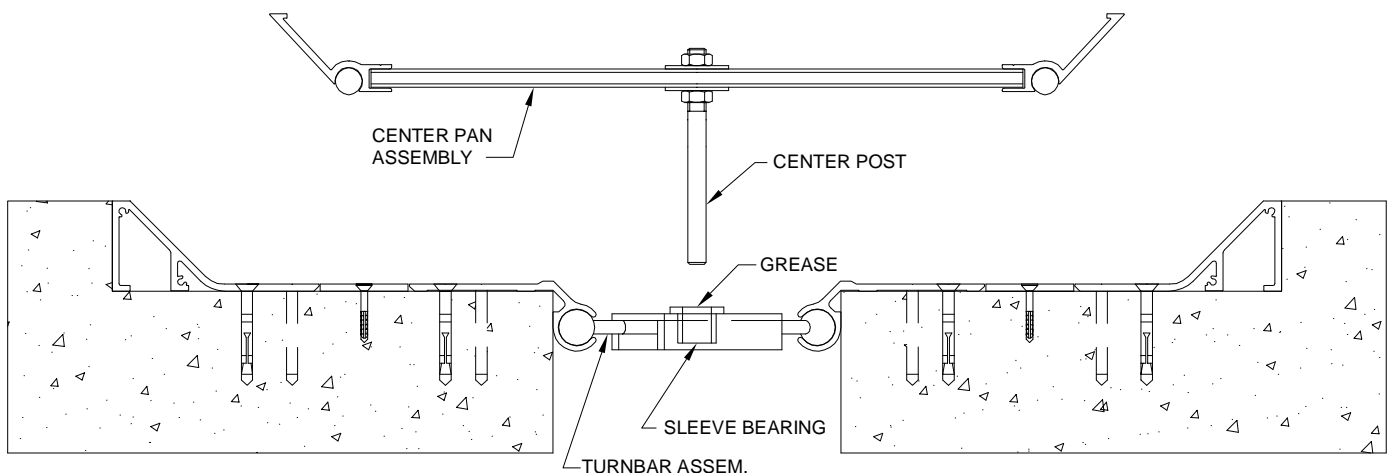

- 7.5) Beginning near the center of the run, position the first Pan along side the joint.
- 7.6) Align the center of the Turnbars so that they match the locations of the Center Posts.
- 7.7) Apply a heavy bead of grease to the inside of the sleeve bearing of each Turnbar.
- 7.8) Hold the Pan over the joint. Align the Center Posts with the Turnbars. Seat the Pan onto the Frames with the Center Posts positioned through the sleeve bearings of the Turnbars.

STEP 8

PAN SPLICING

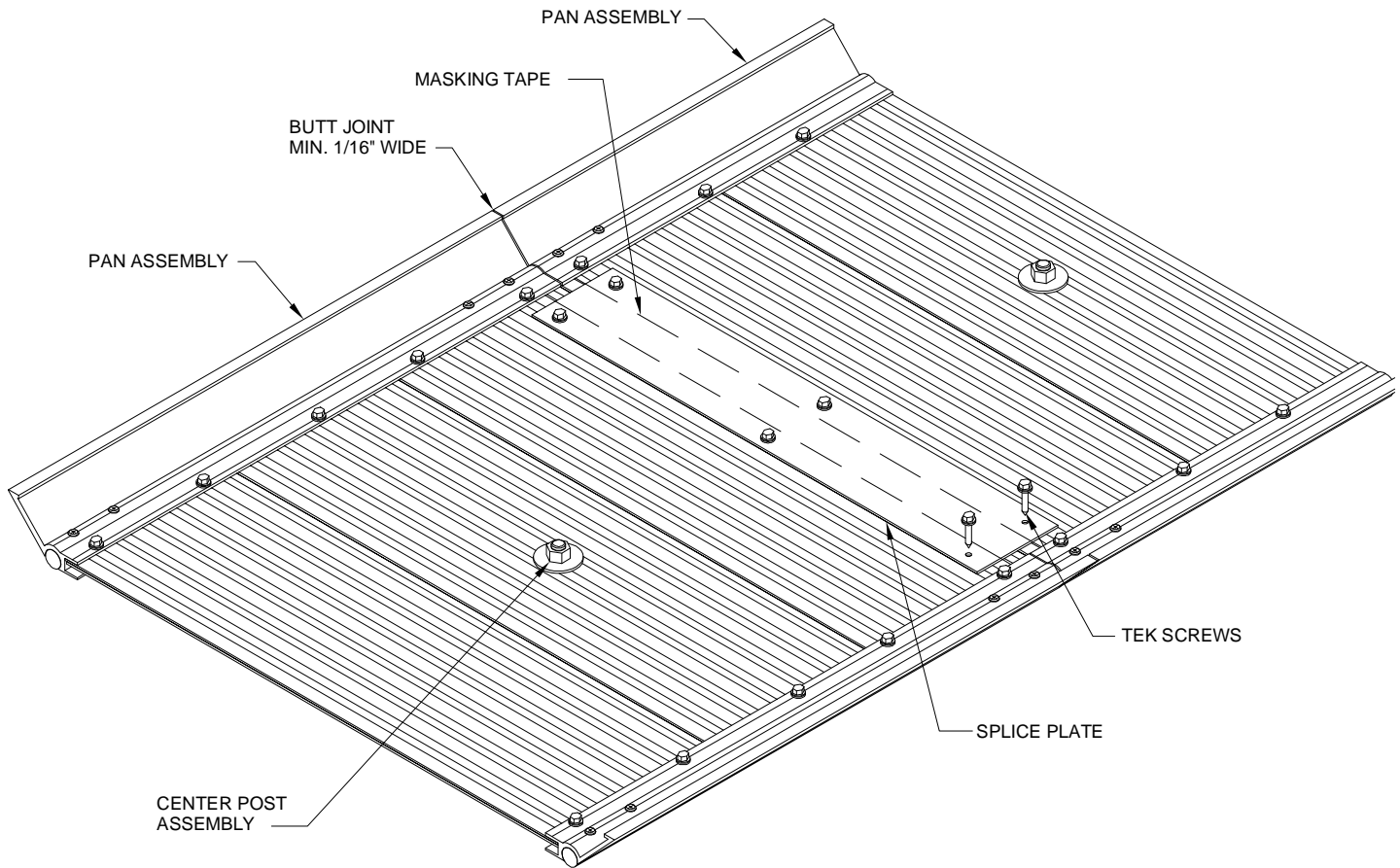

Note: Center Pan Assemblies are supplied in typical 10'-0" lengths. Each Pan is to be field spliced to the adjacent Pans to maintain alignment. A minimum 1/16" gap must be maintained between Pan Assemblies to allow for thermal expansion.

8.1) Place the next Pan Assembly onto the Frames as instructed in Step 7.

8.2) Slide the Pan along the Frames until the ends of the Pans butt together. Separate slightly to maintain a minimum 1/16" gap.

8.3) Adjust the Pans across the joint so that the top corners of the Pan are in alignment.

8.4) Place a strip of masking tape or duct tape on top of the Pans, over the butt joint, for the full width of the Pan.

8.5) Center one of the C/S supplied splice plates over the butt joint and attach to the Pan using the supplied self-drilling tek screws. Note: Maintain the minimum 1/16" gap at the butt joint.

END OF A RUN REQUIREMENTS

Note:

When approaching the ends of a run of cover, several field issues must be considered to complete the installation and maintain proper function of the covers.

- 1) Lateral Shear Movement - If lateral shear movement of the buildings is expected, custom "Pop-Out" End Pans will be required and will be indicated on the approved C/S shop drawings.
- 2) Field Cutting Center Pans - It is likely that a standard 10'-0" length of Center Pan will have to be field cut to fit the exact length between the wall or pop-out Pan and the last standard length of Pan.
- 3) Location of Center Post Assemblies - Depending upon the center-to-center spacing of the Center Post assemblies, the length of the Turnbar Assemblies, and the joint movement requirements, some Center Post assemblies may or may not be needed.

Review the layout below to familiarize yourself with the cover requirements at the end of a run. Then review the next few installation steps before proceeding with installation.

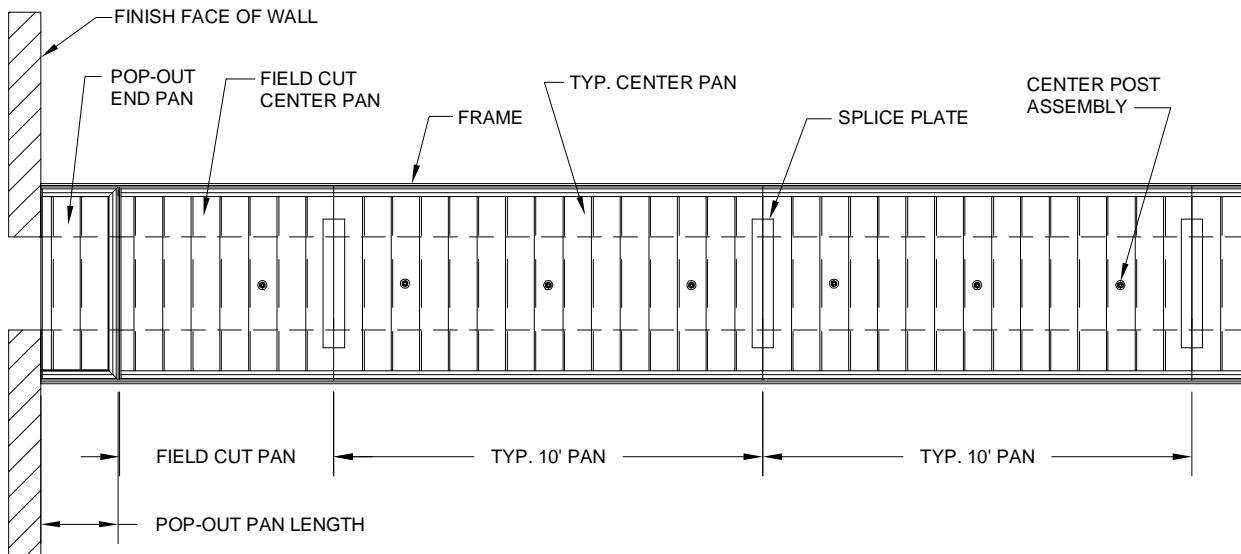

STEP 9

FIELD CUT CENTER PAN

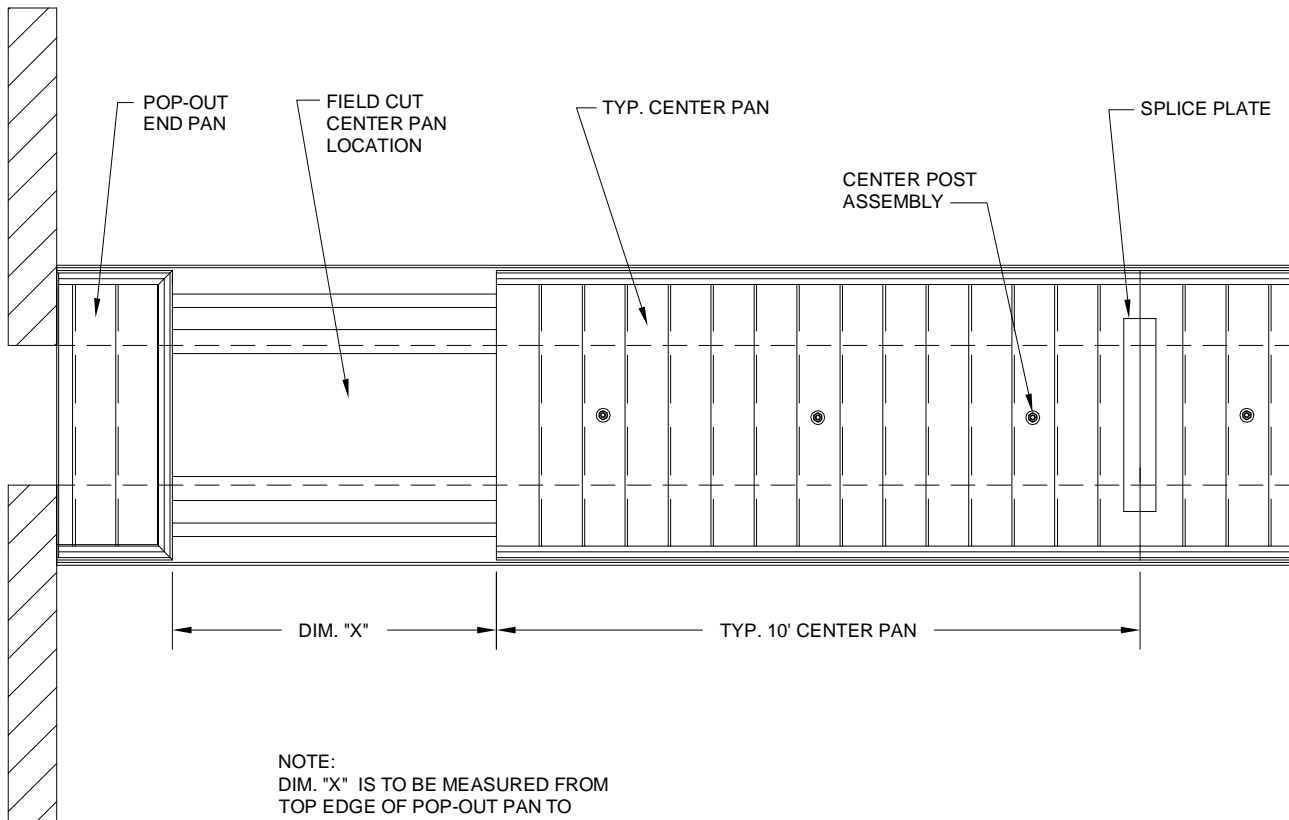

NOTE:
DIM. "X" IS TO BE MEASURED FROM
TOP EDGE OF POP-OUT PAN TO
NEAREST EDGE OF TYP. 10' PAN.

THE ACTUAL FIELD CUTTING LENGTH
IS EQUAL TO DIM. "X" (-) 1".

NOTE: 1" SPACE REQUIRED FOR
CAULK JOINT.

Note: To assist in determining the cut length for the Center Pan, temporarily place one of the custom pop-out end Pans in position at the end of the joint. The flat end of the pop-out Pan should butt to the face of the wall, and the end with the sloped nosing is to face the adjacent Center Pan.

9.1) Measure the distance between the top edge of the sloped nosing of the pop-out Pan, and the nearest edge of the last typical 10' Center Pan (DIM. "X").

9.2) Subtract 1" from Dim. "X" to establish the field cut pan length.

9.3) Measure and mark a length of Center Pan with the required field cut length. Note: Any of the assembly screws (used to attach the components of the Pan together) that may fall on the cut line, should be removed before cutting.

9.4) Using a circular saw with the appropriate blade and a straight edge or saw guide, cut the Center Pan to the required length.

Proceed to Step 10.

STEP 10

PREPARE CUT CENTER PAN FOR INSTALLATION

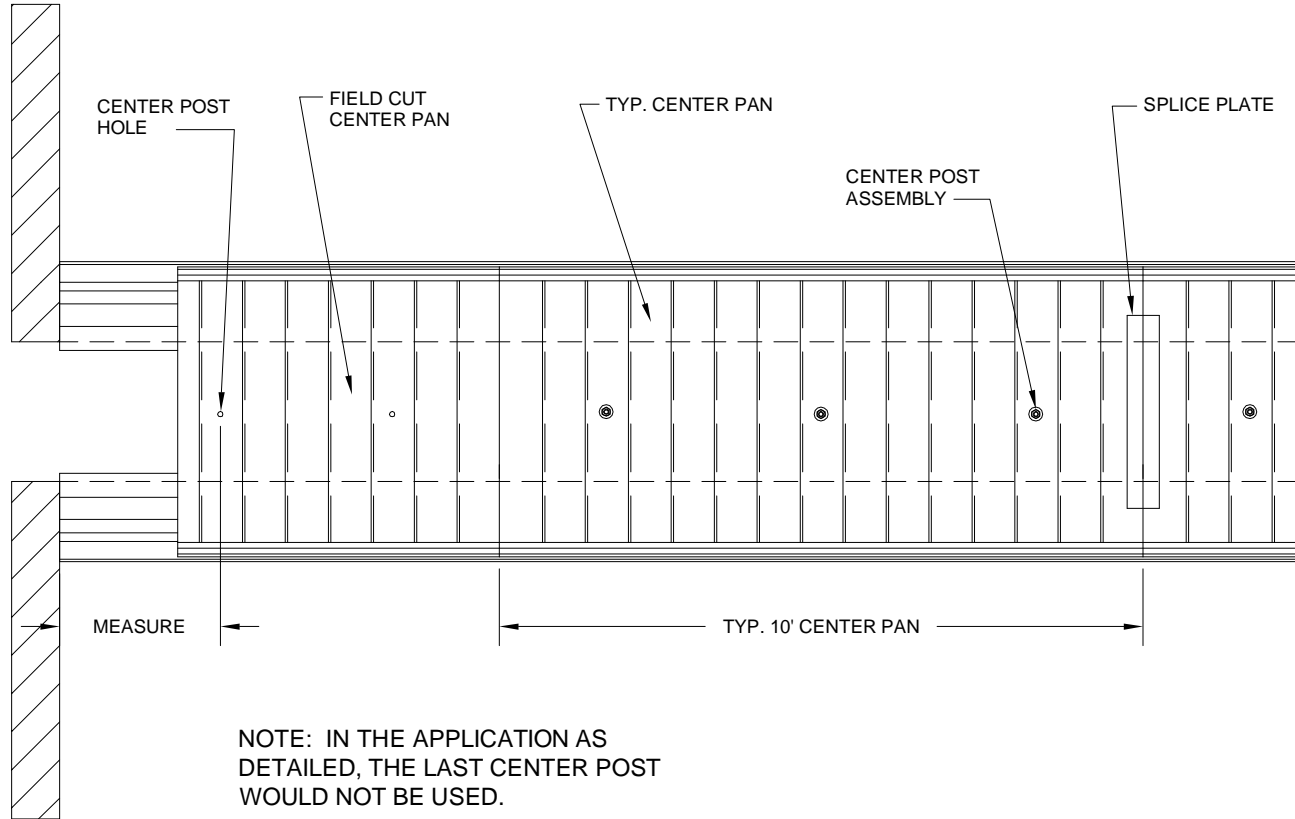

Note: When preparing the field cut Pan for installation, there are two issues to be addressed. The placement of the last Turnbar Assembly in relation to the end of the run, and the installation of the pop-out Pan deflector nosing. Use the following instructions to address these issues.

Turnbar Assembly

Note: When field cutting the Pan to length, it is likely that the cut was made near a Turnbar Center Post location or that one or more post locations have been removed. The location of the Turnbar Assembly that is nearest to the end of the run is important in that the location must be far enough from the end so that the Turnbar will not slide out of the Frame during maximum movement. The dimension for this location must be greater than or equal to the overall length of a Turnbar assembly. Use the following instructions to determine the location for the last Turnbar.

10.1) Temporarily place the cut Pan on to the Base Frames. Position the cut Pan so that the uncut end butts against the last installed 10' Pan.

10.2) Measure the overall length of a Turnbar Assembly.

10.3) Measure from the ends of the run (or face of the wall) to the Center Post location hole nearest the end of the Pan. If the hole location is greater than, or equal to, the Turnbar length, the hole will be used. If the hole location is less than the Turnbar length, simply place duct tape over the hole as it will not be used.

10.4) Remove the cut Pan and install the required number of Center Posts as indicated in Step 7.

10.5) Insert the required number of Turnbar Assemblies (equal to the number of Center Posts) into the Frames as instructed in Step 5.

Note: If the cut Pan length is too short for any Turnbar Assemblies to be used, the Pan will simply be held by the pan splice plate. See Step 8.

STEP 10 (CONT.)

PREPARE CUT CENTER PAN FOR INSTALLATION

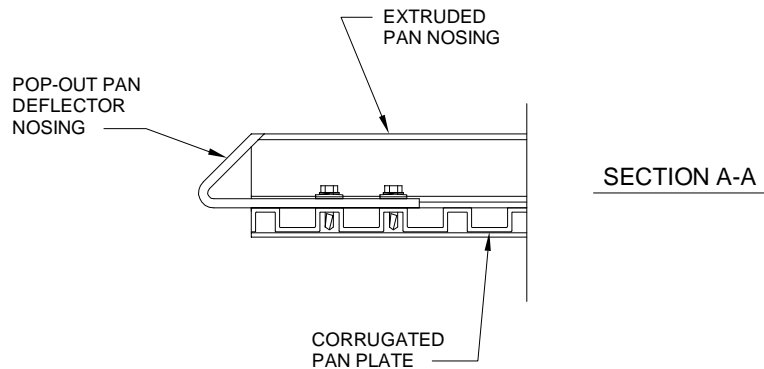
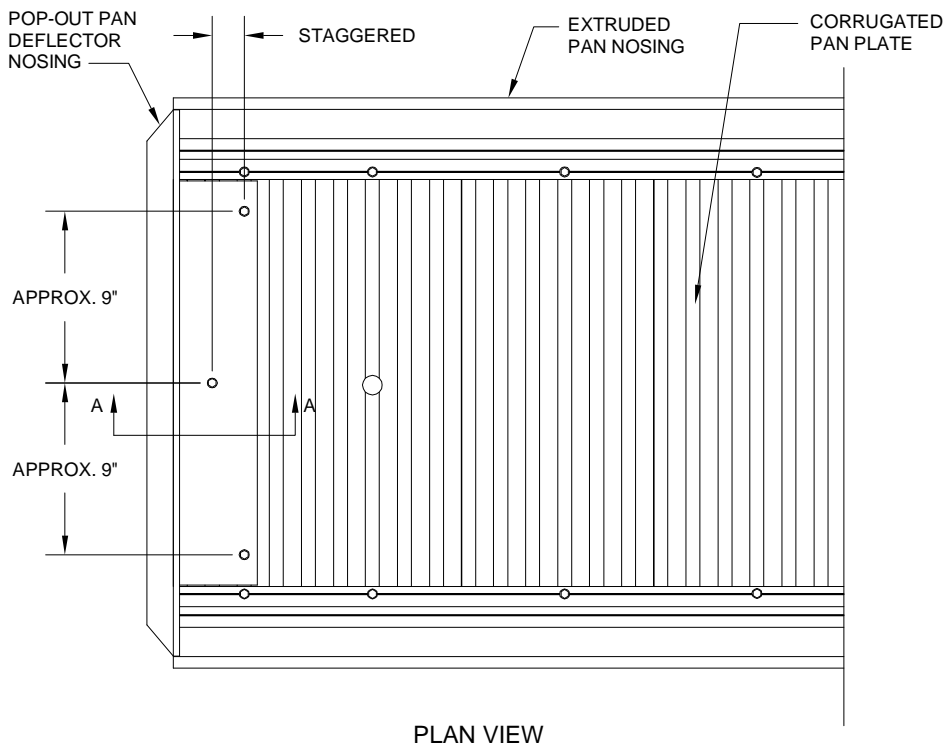

Pop-out Pan Deflector Nosing

Note: Before placing the cut Pan into the blockout, a pop-out Pan deflector nosing must be attached to the cut end of the Pan. The pop-out Pan deflector nosing is a formed aluminum angle that forces the pop-out Pan up and out of the way during seismic movement.

10.6) Locate the pop-out Pan deflector nosing in the appropriate width for the given Pan. To determine appropriate width, measure between the inside edges of the extruded Pan nosings.

10.7) Position the deflector nosing between the extruded Pan nosings with the wide leg on top of the extruded, corrugated Pan plate.

10.8) Anchor the deflector nosing to the Pan as indicated above. Note: The screws are to hit the top flat portions of the corrugations and should be staggered at 18" o.c. maximum.

The field cut Pan is now ready to be installed.

STEP 11

INSTALL CUT PAN AND POP-OUT PAN

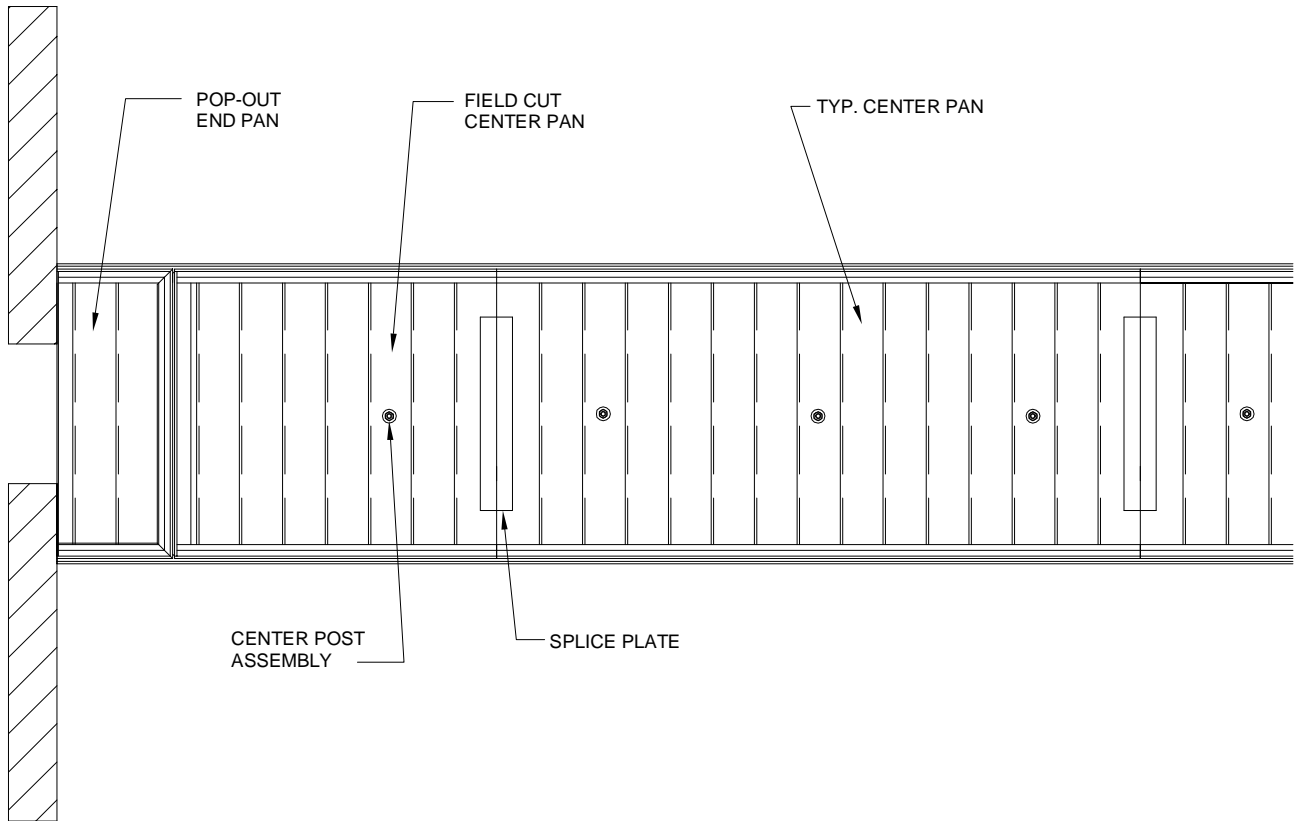

11.1) Position and install the field cut Pan as indicated in Step 7.

11.2) Install the splice plate between the field cut Pan and previous Pan as indicated in Step 8.

11.3) Position the pop-out end Pan into the blockout with the flat side towards the wall and the sloped nosing towards the field cut Pan. Note: There should be a caulk joint of approx. 1" between the pop-out Pan and the field cut Pan.

11.4) Adjust the pop-out Pan so that the caulk joint along each edge is equal.

STEP 12

COMPLETING THE INSTALLATION

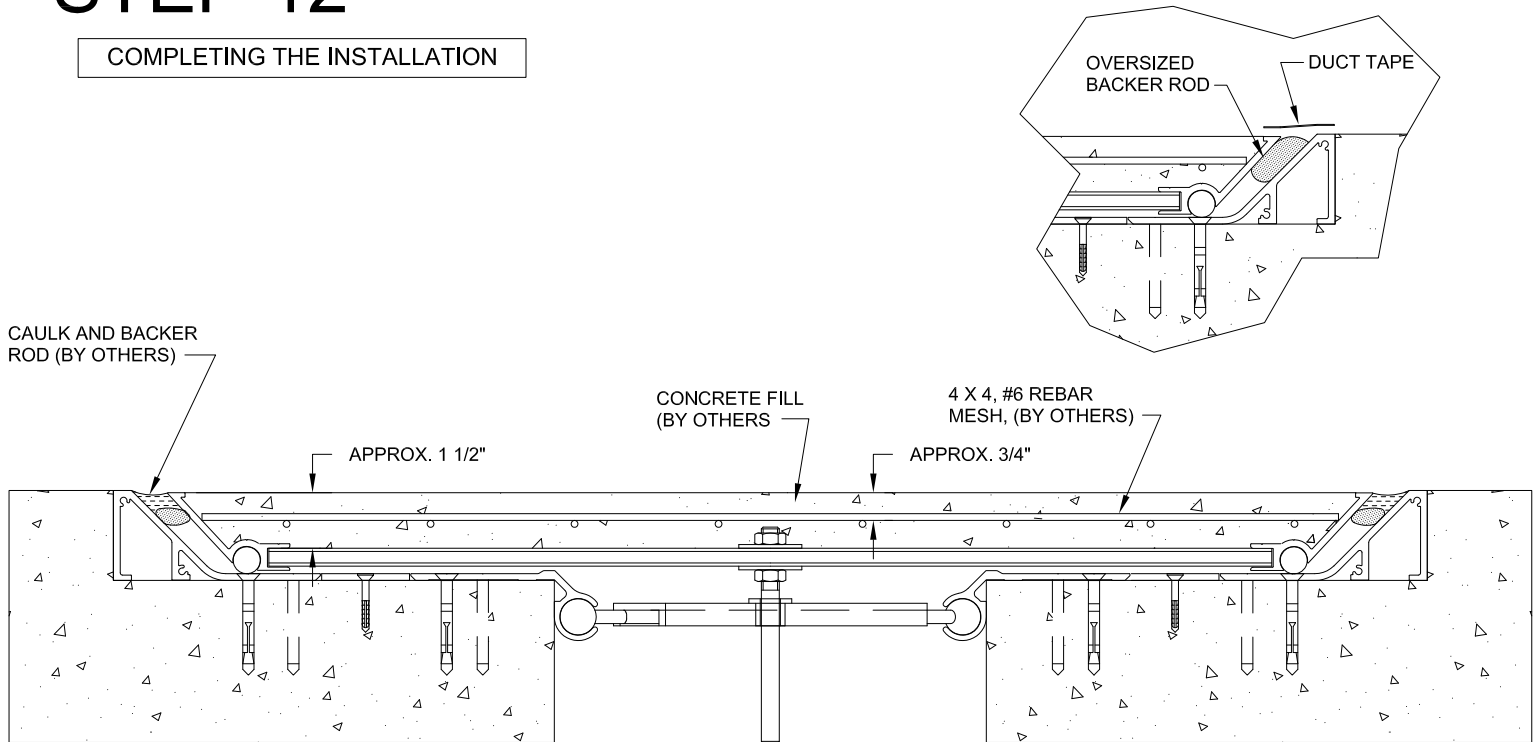

Note: With the Joint Cover Assemblies installed for the full length of the run, the following steps will complete the installation. The steps do not necessarily have to be completed in the order shown.

12.1) Place the C/S supplied oversized backer rod into the slot between the Base Frame and Pan, on each side of the joint, for the full length of the run. The backer rod should be positioned just below the exposed edges of the Base Frame and Pan. **Note:** The backer rod is used to prevent dirt and debris from gathering in the slot between the Frame and Pan that could hinder movement or the resting position of the Pan.

12.2) Place duct tape along the top surface of both the Base Frame and Pan Frame so that it spans over the oversized backer rod. **Note:** The tape will protect the exposed surfaces while the concrete fill is placed.

12.3) Fill any remaining blockout area, adjacent to the Base Frames, with a quality non-shrink grout (by others).

12.4) In the Pan, place 4" x 4", #6 rebar mesh (by others) along the full length of the run. The rebar mesh should span nearly the full width of the Pan, and should be positioned approximately 3/4" below the top surface of the Pan.

IMPORTANT Note: Select the proper concrete mix: Discuss with your local Concrete supplier Engineer to recommend a concrete for this special application in effort to prevent excessive shrinking, curling, and fracturing of the concrete from occurring. Recommendations include: Low water to cement ratio, #8 coarse aggregate, and/or a 60/40 cement to ash combination, greater full cure time (60 day minimum recommended), and a recommended shrinkage admixture. If concrete is being applied outside, canopys or burlap should be used to minimize excessive differential curing from occurring. Concrete should not be installed if there is the possibilities the tempertures could drop below recommended curing tempertures during the curing cycle.

12.5) Fill the Pan with the selected concrete (concrete by others) Float the concrete level with the exposed edges of the Pan. Smooth and finish as required. Apply misters for moist curing (see Important Note:)

IMPORTANT Note: Measures must be taken to prevent excess shrinking and curling from occurring. Construction Specialties recommends the installer moist cure the concrete for a minimum of 12 days. During the final 5 days reduce duration of moist curing incrementally. These efforts will aid in the reduction of differential curing from occurring causing warping of the concrete and possibly damaging the aluminum pans.

STEP 12 Continued

COMPLETING THE INSTALLATION

Included below are links to articles and documentation for additional resources to aid in the reduction of shrinking and warping caused by improperly specified or curing of the concrete.

http://www.cement.org/tech/cct_floors_shrinkage.asp

http://irc.nrc-cnrc.gc.ca/pubs/ctus/44_e.html

IMPORTANT Note: After all misting and troweling has been completed, apply the recommended water based concrete curing compound (not a cure and seal) (by others) to the entire surface of the concrete.

12.6) When the concrete has set or after any other floor finish work is complete, remove the duct tape from along the exposed surface of the Pan and Base Frames. Before removing the oversized backer rod, vacuum off the top surface to remove all loose grout, concrete, dirt and debris that might fall into the slot as the backer rods are removed. Then remove the backer rods.

12.7) Place new backer rods (by others) and caulking (by others) along the full length of the slots between the Pan and Base Frames. The caulk should be smooth and level with the exposed surfaces of the Frame and Pan. Note: To provide the proper thermal expansion and compression capability, select a caulking that will provide +/-50% movement capability per nominal width. We recommend using **Sika® 2C SL** where available. The caulking should be applied per the manufactures recommendations and width to depth ratio.

THE INSTALLATION SHOULD NOW BE COMPLETE. PROTECT THE INSTALLATION UNTIL FINAL ARCHITECTURAL INSPECTION.