



# Expansion Joint Covers

## SJP & SJPW Series

### Technical Data:

#### Aluminum

- Extrusion – C/S uses multiple alloys & tempers which are established to be the most appropriate for the given use of individual parts. Will be one of the following: (6063-T5, T6, T52) (6061-T5, T6, T51) (6105-T5, T6) (6005-T5) (6005A-T5, T61)
- Sheet – 6061-T6, 3003-H14, 5005-H34, ASTM B209

#### Turnbar

- Material – C1075 Blue Temper Spring Steel
- Hardness - RC 44-47
- Finish - "A" Coating (Corrosion Protection)

#### Standard Loading

- 500 lbs.

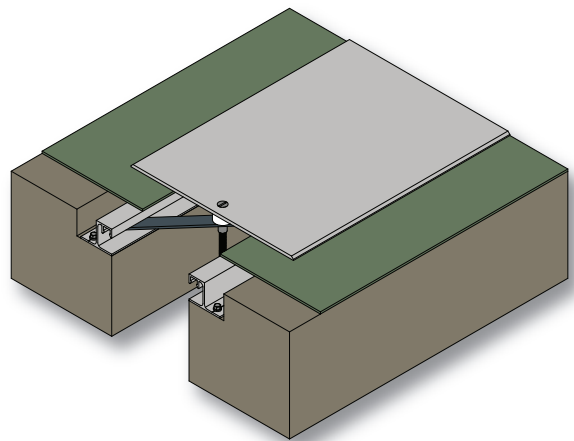

### Product Description:

This Surface Mounted metal floor cover is designed for interior or exterior applications. The joint can be designed for up to 100% movement.

### Use This Cover For:

- Interior or exterior seismic applications.
- Applications requiring movements up to 100% of joint width.
- Larger sizes available (contact factory).
- Optional waterstop available for wet areas.

### Performance Characteristics:

Self-centering aluminum center plate allows for thermal movement and seismic movement.

### Standard Finishes:

Mill finish. Aluminum surfaces in contact with concrete will be protected with a minimum 2 mil coating of a heavy metal free high solids primer.

### Installation Guidelines:

The blockouts must be prepared to receive the joint cover. It is recommended that the blockout be formed a minimum of 1/8" deeper to allow the base to be leveled prior to installation of the joint cover. Apply a high-strength leveling grout to the base of the blockouts to provide a continuous, solid, flat and level base for the joint cover. (Note: The blockouts must be level across the joint opening.) Install base frames with C/S supplied fasteners. Fasten cover plate to frames with turnbar. For complete installation instructions, please visit [www.c-sgroup.com](http://www.c-sgroup.com).

| MODEL     | JOINT WIDTH    | MINIMUM OPENING | MAXIMUM OPENING | EXPOSED SURFACE | BLOCKOUT WIDTH | BLOCKOUT HEIGHT |
|-----------|----------------|-----------------|-----------------|-----------------|----------------|-----------------|
| SJP-100   | 1.00" (25mm)   | 0.50" (13mm)    | 4.00" (102mm)   | 4.50" (114mm)   | 2.50" (64mm)   | 1.50" (38mm)    |
| SJP-200   | 2.00" (51mm)   | 1.00" (25mm)    | 4.50" (114mm)   | 4.50" (114mm)   | 2.25" (57mm)   | 1.50" (38mm)    |
| SJP-300   | 3.00" (76mm)   | 1.00" (25mm)    | 4.75" (121mm)   | 6.50" (165mm)   | 2.25" (57mm)   | 1.50" (38mm)    |
| SJP-400   | 4.00" (102mm)  | 1.00" (25mm)    | 7.50" (191mm)   | 7.50" (191mm)   | 2.25" (57mm)   | 1.50" (38mm)    |
| SJP-500   | 5.00" (127mm)  | 1.00" (25mm)    | 7.50" (191mm)   | 10.50" (267mm)  | 2.25" (57mm)   | 1.50" (38mm)    |
| SJP-600   | 6.00" (152mm)  | 1.00" (25mm)    | 11.13" (283mm)  | 11.88" (302mm)  | 2.25" (57mm)   | 1.50" (38mm)    |
| SJP-700   | 7.00" (178mm)  | 1.00" (25mm)    | 12.25" (311mm)  | 13.50" (343mm)  | 2.25" (57mm)   | 1.50" (38mm)    |
| SJP-800   | 8.00" (203mm)  | 1.00" (25mm)    | 14.25" (362mm)  | 15.00" (381mm)  | 2.25" (57mm)   | 1.50" (38mm)    |
| SJP-900   | 9.00" (229mm)  | 1.00" (25mm)    | 16.50" (419mm)  | 16.50" (419mm)  | 2.25" (57mm)   | 1.50" (38mm)    |
| SJP-1000  | 10.00" (254mm) | 1.00" (25mm)    | 16.75" (425mm)  | 17.94" (456mm)  | 2.25" (57mm)   | 1.50" (38mm)    |
| SJP-1100  | 11.00" (279mm) | 1.00" (25mm)    | 16.75" (425mm)  | 19.50" (495mm)  | 2.25" (57mm)   | 1.50" (38mm)    |
| SJP-1200  | 12.00" (305mm) | 1.00" (25mm)    | 21.00" (533mm)  | 21.00" (533mm)  | 2.25" (57mm)   | 1.50" (38mm)    |
| SJP-1300  | 13.00" (330mm) | 1.00" (25mm)    | 21.00" (533mm)  | 22.50" (572mm)  | 2.25" (57mm)   | 1.50" (38mm)    |
| SJP-1400  | 14.00" (356mm) | 1.00" (25mm)    | 23.75" (603mm)  | 23.88" (606mm)  | 2.25" (57mm)   | 1.50" (38mm)    |
| SJP-1500  | 15.00" (381mm) | 1.00" (25mm)    | 24.25" (616mm)  | 25.50" (648mm)  | 2.25" (57mm)   | 1.50" (38mm)    |
| SJP-1600  | 16.00" (406mm) | 1.00" (25mm)    | 24.25" (616mm)  | 27.00" (686mm)  | 2.25" (57mm)   | 1.50" (38mm)    |
| SJPW-100  | 1.00" (25mm)   | 0.00" (0mm)     | 2.50" (64mm)    | 2.75" (70mm)    | 2.50" (64mm)   | 1.50" (38mm)    |
| SJPW-200  | 2.00" (51mm)   | 0.00" (0mm)     | 3.25" (83mm)    | 3.25" (83mm)    | 2.25" (57mm)   | 1.50" (38mm)    |
| SJPW-300  | 3.00" (76mm)   | 0.00" (0mm)     | 3.75" (95mm)    | 4.75" (121mm)   | 2.25" (57mm)   | 1.50" (38mm)    |
| SJPW-400  | 4.00" (102mm)  | 0.00" (0mm)     | 5.75" (146mm)   | 5.75" (146mm)   | 2.25" (57mm)   | 1.50" (38mm)    |
| SJPW-500  | 5.00" (127mm)  | 0.00" (0mm)     | 6.25" (159mm)   | 7.75" (197mm)   | 2.25" (57mm)   | 1.50" (38mm)    |
| SJPW-600  | 6.00" (152mm)  | 0.00" (0mm)     | 8.50" (216mm)   | 8.94" (227mm)   | 2.25" (57mm)   | 1.50" (38mm)    |
| SJPW-700  | 7.00" (178mm)  | 4.00" (102mm)   | 9.50" (241mm)   | 10.25" (260mm)  | 2.25" (57mm)   | 1.50" (38mm)    |
| SJPW-800  | 8.00" (203mm)  | 4.50" (114mm)   | 10.00" (254mm)  | 11.50" (292mm)  | 2.25" (57mm)   | 1.50" (38mm)    |
| SJPW-900  | 9.00" (229mm)  | 5.00" (127mm)   | 12.75" (324mm)  | 12.75" (324mm)  | 2.25" (57mm)   | 1.50" (38mm)    |
| SJPW-1000 | 10.00" (254mm) | 5.50" (140mm)   | 13.31" (338mm)  | 14.00" (356mm)  | 2.25" (57mm)   | 1.50" (38mm)    |
| SJPW-1100 | 11.00" (279mm) | 6.00" (152mm)   | 13.88" (353mm)  | 15.25" (387mm)  | 2.25" (57mm)   | 1.50" (38mm)    |
| SJPW-1200 | 12.00" (305mm) | 6.50" (165mm)   | 16.50" (419mm)  | 16.50" (419mm)  | 2.25" (57mm)   | 1.50" (38mm)    |
| SJPW-1300 | 13.00" (330mm) | 7.00" (178mm)   | 17.00" (432mm)  | 17.75" (451mm)  | 2.25" (57mm)   | 1.50" (38mm)    |
| SJPW-1400 | 14.00" (356mm) | 7.50" (191mm)   | 18.75" (476mm)  | 18.94" (481mm)  | 2.25" (57mm)   | 1.50" (38mm)    |
| SJPW-1500 | 15.00" (381mm) | 8.00" (203mm)   | 19.50" (495mm)  | 20.25" (514mm)  | 2.25" (57mm)   | 1.50" (38mm)    |
| SJPW-1600 | 16.00" (406mm) | 8.50" (216mm)   | 20.00" (508mm)  | 21.50" (546mm)  | 2.25" (57mm)   | 1.50" (38mm)    |

Contact factory for larger sizes.

