



Expansion Joint Covers

SGR & SGRW Series

Technical Data:

Aluminum

- Extrusion – C/S uses multiple alloys & tempers which are established to be the most appropriate for the given use of individual parts. Will be one of the following: (6063-T5, T6, T52) (6061-T5, T6, T51) (6105-T5, T6) (6005-T5) (6005A-T5, T61)
- Sheet – 6061-T6, 3003-H14, 5005-H34, ASTM B209

Primary Seal

- Dual Durometer 65 Shore A, 90 Shore A, ASTM D2000
- Available in 4 colors.

Turnbar

- Material -C1075 Blue Temper Spring Steel
- Hardness - RC 44-47
- Finish - "A" Coating (Corrosion Protection)

Standard Loading

- 500 lbs.

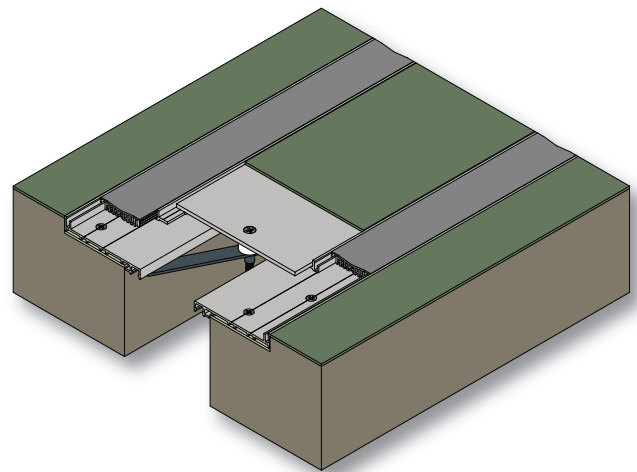

Product Description:

This dual gasket, flush floor cover is ideal for areas with larger movement requirements and where a concealed cover is desired. The joint can be designed for up to 100% movement.

Use This Cover For:

- Seismic interior applications requiring a completely flush joint cover virtually concealed in the surrounding floor finishes.
- Cover offers a 1/8" recessed center plate to accept carpet or vinyl flooring.
- Where wheeled equipment is to be used.
- Where hygiene is important.

Performance Characteristics:

The dual durometer thermoplastic gasket has rigid edges designed to lock into the aluminum side frames. This prevents hairline gaps from opening between the gasket and frame ensuring a hygienic seal. The softer center section of the gasket allows full movement without the need for grooves in the top surface which collect dirt. The rigid edges also prevent the gasket from being cut by heavy rolling loads that tend to destroy conventional gaskets. Dual gaskets allow for greater expansion and compression during movement. Durable aluminum plate spans joint opening. This model also features a self-centering or turnbar device to keep the plate centered during seismic cycling. This unique movement design also incorporates a deflector, or "seismic policeman" on the bottom side of the center plate. As the joint closes during seismic cycling, deflectors come into contact with the side frames, and the plate is elevated in order to prevent damage.

Standard Finishes:

Mill finish. Gasket is available in Black, White, Gray, & Greige. Aluminum in contact with concrete/masonry will have a 2 mil heavy metal free high solids primer.

Installation Guidelines:

The blockouts must be prepared to receive the joint cover. Depth may be adjusted as needed to accommodate a floor finish material when required. It is recommended that the breakout be formed a minimum of 1/8" deeper to allow the base to be leveled prior to installation of the joint cover. Apply a high-strength leveling grout to the base of the blockouts to provide a continuous, solid, flat and level base for the joint cover. (Note: The blockouts must be level across the joint opening.) Install base frames with C/S supplied fasteners. Fasten cover plate to frames with turnbar. Insert gaskets. For complete installation instructions, please visit www.c-sgroup.com.

To download detail, specs & photos visit www.c-sgroup.com
For technical and design assistance call 800-233-8493.

MODEL	JOINT WIDTH	MINIMUM OPENING	MAXIMUM OPENING	EXPOSED SURFACE	BLOCKOUT WIDTH	BLOCKOUT HEIGHT
SGR-500	5.00" (127mm)	2.50" (64mm)	9.25" (235mm)	12.00" (305mm)	3.50" (89mm)	0.75" (19mm)
SGR-600	6.00" (152mm)	2.75" (70mm)	9.50" (241mm)	13.00" (330mm)	3.50" (89mm)	0.75" (19mm)
SGR-700	7.00" (178mm)	2.75" (70mm)	12.25" (311mm)	15.00" (381mm)	4.00" (102mm)	0.75" (19mm)
SGR-800	8.00" (203mm)	2.75" (70mm)	13.25" (337mm)	16.00" (406mm)	4.00" (102mm)	0.75" (19mm)
SGR-900	9.00" (229mm)	2.75" (70mm)	14.25" (362mm)	18.00" (457mm)	4.50" (114mm)	0.75" (19mm)
SGR-1000	10.00" (254mm)	2.75" (70mm)	16.25" (413mm)	19.00" (483mm)	4.50" (114mm)	0.75" (19mm)
SGR-1100	11.00" (279mm)	2.75" (70mm)	18.25" (464mm)	21.00" (533mm)	5.00" (127mm)	0.75" (19mm)
SGR-1200	12.00" (305mm)	2.75" (70mm)	18.50" (470mm)	22.00" (559mm)	5.00" (127mm)	0.75" (19mm)
SGR-1300	13.00" (330mm)	2.75" (70mm)	21.25" (540mm)	24.00" (610mm)	5.50" (140mm)	0.75" (19mm)
SGR-1400	14.00" (356mm)	2.75" (70mm)	22.25" (565mm)	25.00" (635mm)	5.50" (140mm)	0.75" (19mm)
SGR-1500	15.00" (381mm)	2.75" (70mm)	23.00" (584mm)	27.00" (686mm)	6.00" (152mm)	0.75" (19mm)
SGR-1600	16.00" (406mm)	2.75" (70mm)	25.25" (641mm)	28.00" (711mm)	6.00" (152mm)	0.75" (19mm)
SGRW-500	5.00" (127mm)	4.25" (108mm)	7.75" (197mm)	8.50" (216mm)	3.50" (89mm)	0.75" (19mm)
SGRW-600	6.00" (152mm)	4.25" (108mm)	7.75" (197mm)	9.50" (241mm)	3.50" (89mm)	0.75" (19mm)
SGRW-700	7.00" (178mm)	5.00" (127mm)	9.50" (241mm)	11.00" (279mm)	4.00" (102mm)	0.75" (19mm)
SGRW-800	8.00" (203mm)	5.50" (140mm)	10.50" (267mm)	12.00" (305mm)	4.00" (102mm)	0.75" (19mm)
SGRW-900	9.00" (229mm)	6.00" (152mm)	11.50" (292mm)	13.50" (343mm)	4.50" (114mm)	0.75" (19mm)
SGRW-1000	10.00" (254mm)	6.50" (165mm)	13.00" (330mm)	14.50" (368mm)	4.50" (114mm)	0.75" (19mm)
SGRW-1100	11.00" (279mm)	7.00" (178mm)	14.50" (368mm)	16.00" (406mm)	5.00" (127mm)	0.75" (19mm)
SGRW-1200	12.00" (305mm)	7.50" (191mm)	15.25" (387mm)	17.00" (432mm)	5.00" (127mm)	0.75" (19mm)
SGRW-1300	13.00" (330mm)	8.00" (203mm)	17.00" (432mm)	18.50" (470mm)	5.50" (140mm)	0.75" (19mm)
SGRW-1400	14.00" (356mm)	8.50" (216mm)	18.00" (457mm)	19.50" (495mm)	5.50" (140mm)	0.75" (19mm)
SGRW-1500	15.00" (381mm)	9.00" (229mm)	19.00" (483mm)	21.00" (533mm)	6.00" (152mm)	0.75" (19mm)
SGRW-1600	16.00" (406mm)	9.50" (241mm)	20.50" (521mm)	22.00" (559mm)	6.00" (152mm)	0.75" (19mm)

Call factory for joints larger than 16"

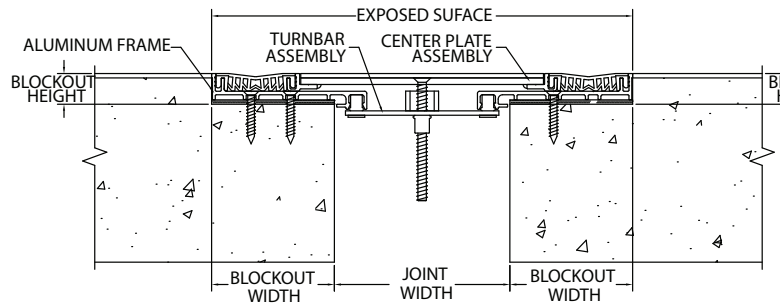

SGR (TYP.)

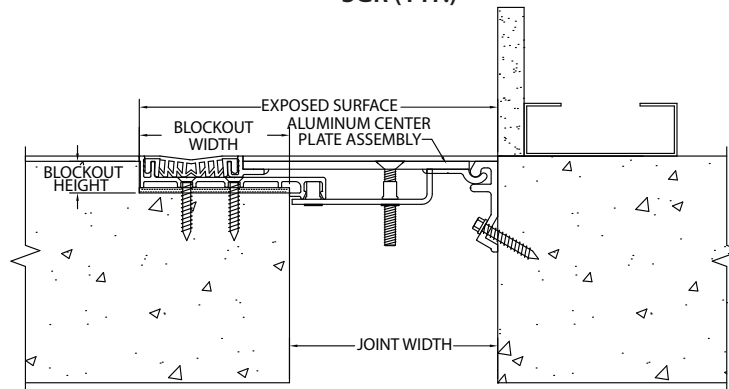

SGRW (TYP.)