



Expansion Joint Covers

SFC-S & SCC-S Series

SFC-B & SCC-B Series

Technical Data:

Aluminum

- Extrusion – C/S uses multiple alloys & tempers which are established to be the most appropriate for the given use of individual parts. Will be one of the following: (6063-T5, T6, T52) (6061-T5, T6, T51) (6105-T5, T6) (6005-T5) (6005A-T5, T61)
- Sheet – 6061-T6, 3003-H14, 5005-H34, ASTM B209

Turnbar

- Material – C1075 Blue Temper Spring Steel
- Hardness - RC 44-47
- Finish - "A" Coating (Corrosion Protection)

Bronze

- C28000 Muntz Metal ASTM B455

Stainless Steel

- Type 304 ASTM A167, A240A, A240M

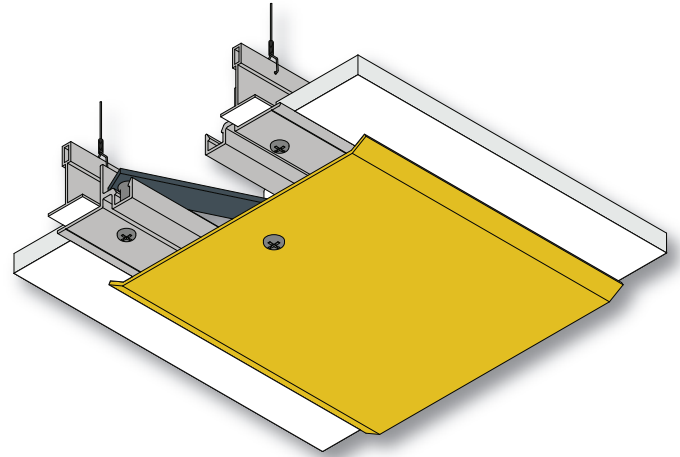

Product Description:

This surface mounted metal ceiling cover is designed for interior applications where low maintenance is desirable

Use This Cover For:

- Interior applications to match Allway metal wall covers.
- Interior applications where low maintenance is desirable.

Performance Characteristics:

Self-centering aluminum center plate spans joint and slides between frame assemblies to allow movement when required. Cover can be painted to match wall finish.

Standard Finishes:

Bronze – Satin Finish.

Stainless Steel – No. 4 Finish.

Installation Guidelines:

Install the frame with the fasteners as supplied by C/S. This model also uses a turnbar assembly. There are some great tips in the complete C/S installation instructions. For the complete installation instructions, please visit www.csgroup.com.

MODEL	JOINT WIDTH	MINIMUM OPENING	MAXIMUM OPENING	EXPOSED SURFACE	BLOCKOUT WIDTH	BLOCKOUT HEIGHT
SFC-400 S/B	4.00" (102mm)	2.75" (70mm)	7.25" (184mm)	7.50" (191mm)	N/A	N/A
SFC-500 S/B	5.00" (127mm)	2.75" (70mm)	9.50" (241mm)	10.50" (267mm)	N/A	N/A
SFC-600 S/B	6.00" (152mm)	2.75" (70mm)	9.50" (241mm)	11.94" (303mm)	N/A	N/A
SFC-700 S/B	7.00" (178mm)	2.75" (70mm)	13.25" (337mm)	13.50" (343mm)	N/A	N/A
SFC-800 S/B	8.00" (203mm)	2.75" (70mm)	14.75" (375mm)	15.00" (381mm)	N/A	N/A
SFC-900 S/B	9.00" (229mm)	2.75" (70mm)	14.25" (362mm)	16.50" (419mm)	N/A	N/A
SCC-400 S/B	4.00" (102mm)	0.00" (0mm)	5.50" (140mm)	5.75" (146mm)	N/A	N/A
SCC-500 S/B	5.00" (127mm)	0.00" (0mm)	7.50" (191mm)	7.50" (191mm)	N/A	N/A
SCC-600 S/B	6.00" (152mm)	0.00" (0mm)	8.75" (222mm)	9.00" (229mm)	N/A	N/A
SCC-700 S/B	7.00" (178mm)	5.00" (127mm)	10.00" (254mm)	10.25" (260mm)	N/A	N/A
SCC-800 S/B	8.00" (203mm)	5.50" (140mm)	11.25" (286mm)	11.50" (292mm)	N/A	N/A
SCC-900 S/B	9.00" (229mm)	6.00" (152mm)	11.50" (292mm)	12.75" (324mm)	N/A	N/A

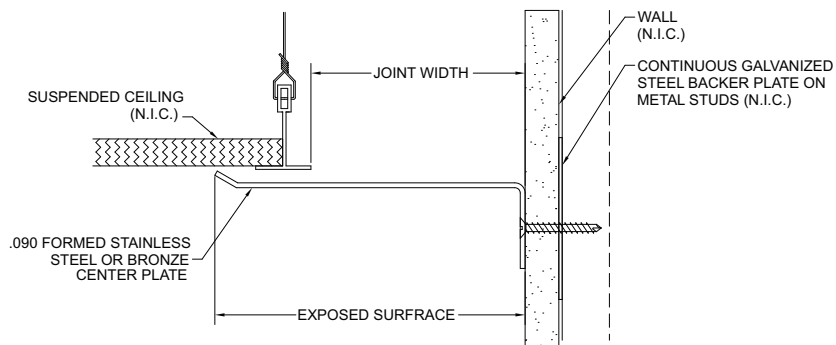

SFC-S/B (TYP.)

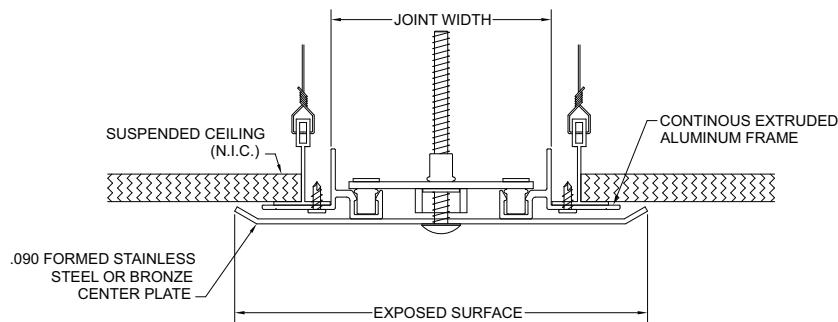

SCC-S/B (TYP.)

CS Expansion Joint Covers:

The following wall covers can also be used in ceiling conditions:

AFW & AFWC – Various finishes	2.29
AFW-B & AFWC-B – Various finishes	2.31
AFW-S & AFWC-S – Various finishes	2.31
ASM & ASMC – Various finishes	2.33
ASM-B & ASMC-B – Various finishes	2.35
ASM-S & ASMC-S – Various finishes	2.35
FWF & FWFC – Gyp. only.	2.3, 2.9, & 2.13
FWF-M & FWFC-M – Various finishes	2.5, 2.11 & 2.15
FWS & FWSC – Gyp. only	2.17 & 2.21
FWS-M & FWSC-M – Various finishes	2.19 & 2.23
GTW & GTWC – Various finishes	2.25
LAF & LAFC – Various finishes	2.41
LAS & LASC – Various finishes	2.43