



Expansion Joint Covers

SF 600/1000 Series

Technical Data:

Aluminum

- Extrusion – C/S uses multiple alloys & tempers which are established to be the most appropriate for the given use of individual parts. Will be one of the following: (6063-T5, T6, T52) (6061-T5, T6, T51) (6105-T5, T6) (6005-T5) (6005A-T5, T61)

Santoprene™ Primary Seal

- Single Durometer: 70 Shore A, ASTM D2000
- Color: 4 standard
- Brittle Point: -76°F
- Ozone Resistance: No Cracks, ASTM D1149
- UV Resistance: Very Good

Secondary Seal

- Material – PVC, ASTM D2000
- Durometer – 65 Shore A

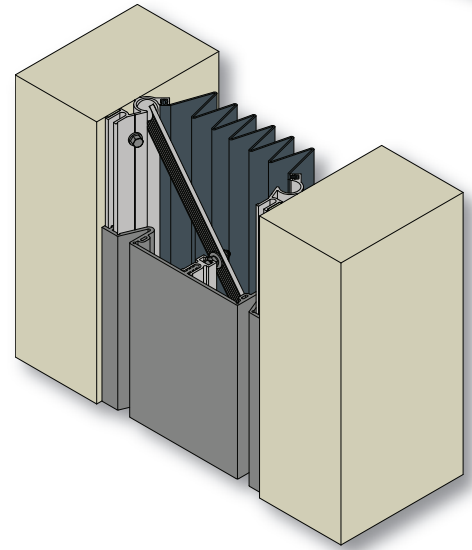

Product Description:

SF is a gasketed exterior wall cover comprised of extruded aluminum frames, a Santoprene™ primary seal and a PVC secondary seal. This seal is designed to accommodate 50% movement.

Use This Cover For:

- Exterior vertical applications where weather protection is critical.
- Frames designed to attach to most exterior finishes.
- 6" to 10" joint sizes with multi-directional movement.
- Factory welded transitions available.
- Four standard gasket colors.

Performance Characteristics:

Flush profile, colorable seals for exterior applications, expand and compress during movement while providing a weather tight seal.

Standard Finishes:

Gasket is available in Black, White, Gray and Greige. Custom colors available.

Installation Guidelines:

No blockouts required. The joint width should be consistent and smooth, respective to its nominal size. Apply butyl tape to aluminum frame and attach inside joint opening with C/S supplied fasteners. Apply sealant to aluminum frames and insert secondary seal and primary seal. For the complete installation instructions, please visit www.c-sgroup.com.

MODEL	JOINT WIDTH	MINIMUM OPENING	MAXIMUM OPENING	EXPOSED SURFACE	BLOCKOUT WIDTH	BLOCKOUT HEIGHT
SF-600	6.00" (152mm)	1.75" (44mm)	9.00" (229mm)	6.00" (152mm)	N/A	N/A
SF-700	7.00" (178mm)	2.50" (64mm)	10.50" (267mm)	7.00" (178mm)	N/A	N/A
SF-800	8.00" (203mm)	2.50" (64mm)	12.00" (305mm)	8.00" (203mm)	N/A	N/A
SF-900	9.00" (229mm)	2.50" (64mm)	13.50" (343mm)	9.00" (229mm)	N/A	N/A
SF-1000	10.00" (254mm)	2.50" (64mm)	15.00" (381mm)	10.00" (254mm)	N/A	N/A

NOTE: Turnbar not required on 6" Model

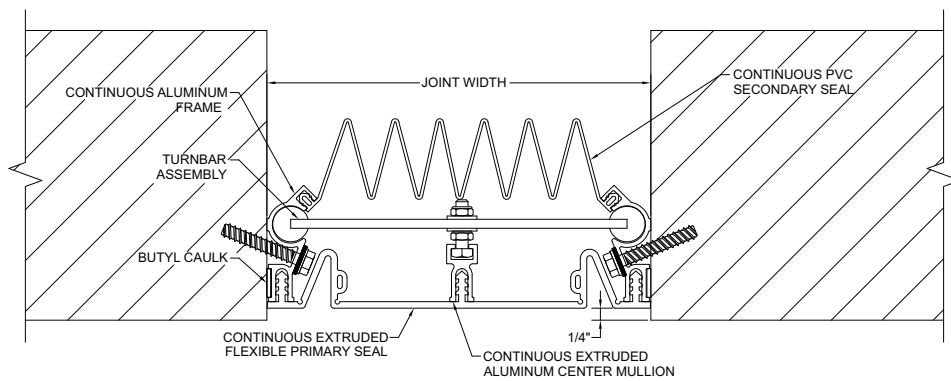

SF-600/1000

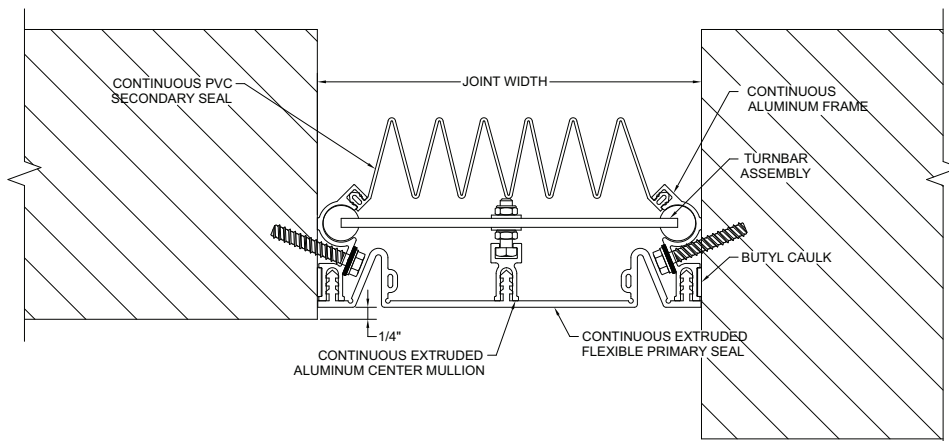

SF-600/1000 (Corner)