



Expansion Joint Covers

SC 300/400 Series

Technical Data:

Aluminum

- Extrusion – C/S uses multiple alloys & tempers which are established to be the most appropriate for the given use of individual parts. Will be one of the following: (6063-T5, T6, T52) (6061-T5, T6, T51) (6105-T5, T6) (6005-T5) (6005A-T5, T61)

Santoprene™ Primary Seal

- Single Durometer: 70 Shore A, ASTM D2000
- Color: 4 standard
- Brittle Point: -76°F
- Ozone Resistance: No Cracks, ASTM D1149
- UV Resistance: Very Good

Secondary Seal

- Material – PVC ASTM D2000
- Durometer – 65 Shore A

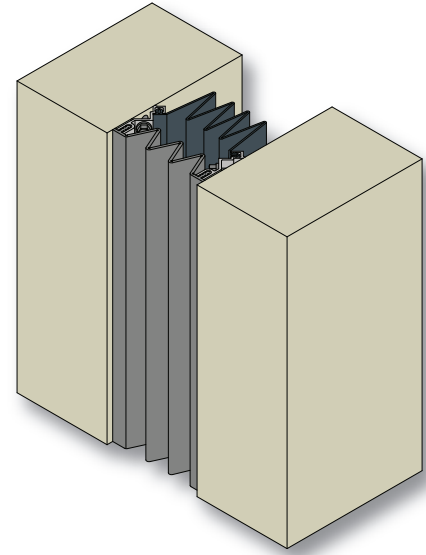

Product Description:

SC is a gasketed exterior wall cover comprised of extruded aluminum frames, a Santoprene™ primary seal and a PVC secondary seal.

Use This Cover For:

- Exterior vertical applications where weather protection is critical.
- Frames designed to attach to most exterior finishes.
- 3" to 4" joint sizes with multi-directional movement.
- Factory welded transitions available.
- Four standard gasket colors.

Performance Characteristics:

Serrated profile, colorable seals for exterior applications, expand and compress during movement while providing a weather tight seal.

Standard Finishes:

Gasket is available in Black, White, Gray and Greige. Custom colors available.

Installation Guidelines:

No blockouts required. The joint width should be consistent and smooth, respective to its nominal size. Apply butyl tape to aluminum frame and attach inside joint opening with C/S supplied fasteners. Apply sealant to aluminum frames and insert secondary seal and primary seal. For the complete installation instructions, please visit www.c-sgroup.com.

MODEL	JOINT WIDTH	MINIMUM OPENING	MAXIMUM OPENING	EXPOSED SURFACE	BLOCKOUT WIDTH	BLOCKOUT HEIGHT
SC-300	3.00" (76mm)	1.25" (32mm)	6.00" (152mm)	3.00" (76mm)	N/A	N/A
SC-400	4.00" (102mm)	1.25" (32mm)	8.00" (203mm)	4.00" (102mm)	N/A	N/A

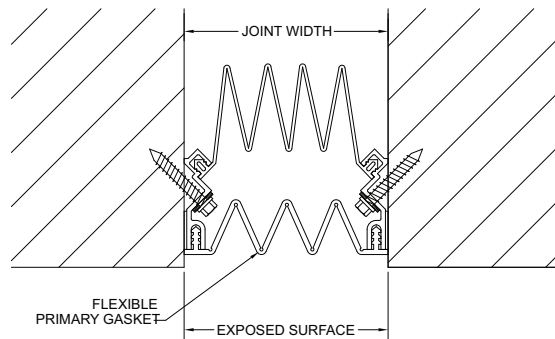

SC-300/400

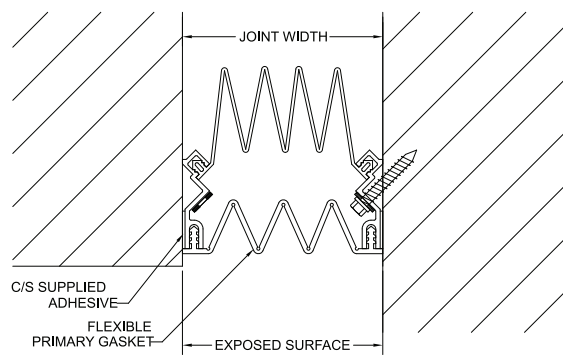

SC-300/400 (Corner)