

Reflex[®] 3" Floor

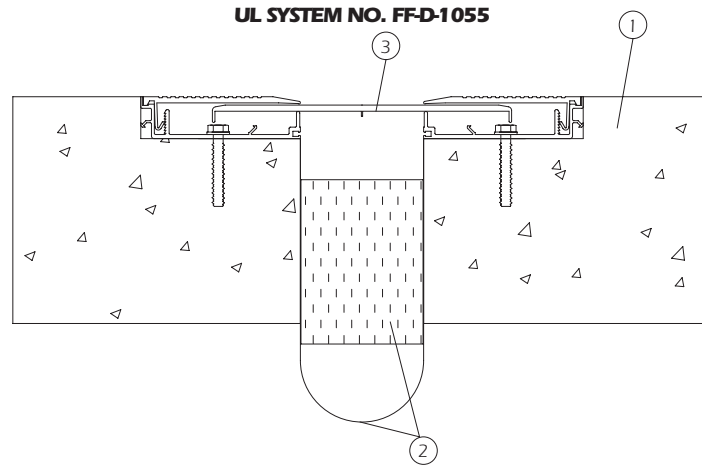

UL[®] Classification
2-Hour Rated



1. **Floor or Wall Assembly** — Reinforced lightweight or normal weight (100-150 pcf or 1600-2400 kg/m³) concrete having a min thickness of 4-1/2 in. (114 mm) at stepped-edges receiving joint cover (Item 3).
2. **Mechanical Joint Assembly*** — Nom width of joint (at time of installation of joint system) is 3 in. (76mm). The joint system fire barrier consists of a foil heat shield and an insulation block. The joint system fire barrier shall be installed in accordance with the installation instructions accompanying the units.

CONSTRUCTION SPECIALTIES INC — RFX-3F

3. **Joint Cover** — Min 0.030 in. (0.76 mm) thick joint cover formed of aluminum, bronze, stainless steel or galv steel. As an alternate, where the linear joint opening is enclosed within a chase wall and is non load bearing, a cover consisting of a creased sheet of min 2 mil stainless steel foil secured with 1 in. wide continuous galv steel washer strips along each side of the joint opening may be used. Joint cover anchored to floor slab on each side of joint opening, continuous over entire length of joint, in accordance with the manufacturer's installation instructions.

*Bearing the UL Classification Mark

UL Label †



†APPLIED TO FIRE BARRIER MATERIAL