

# Multiflex<sup>®</sup> 3"-6" Wall

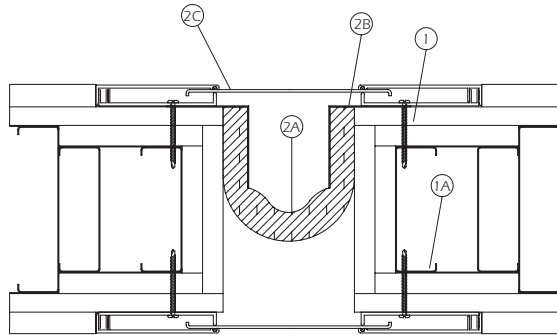

UL<sup>®</sup> Classification  
1 & 2-Hour Rated

UL SYSTEM NO. WW-D-1056



1. **Wall Assembly** — The 1 or 2 hr fire rated gypsum wallboard/steel stud wall assembly shall be constructed of the materials and in the manner described in the individual U300 or U400-Series Wall or Partition Design in the UL Fire Resistance Directory and shall include the following construction features:
  - A. **Studs** — Wall framing may consist of either wood studs or steel channel studs. Wood studs to consist of nom 2 by 4 in. (or larger) lumber spaced 16 in. OC. Steel studs to be min 3-5/8 in. wide and spaced max 24 in. OC.
  - B. **Gypsum Board\*** — Wallboard sheets to be installed to a min total thickness of 5/8 or 1-1/4 in. on each side of the wall for a 1 or 2 hr rated assemblies, respectively. Additional wallboard sheets installed to a min total thickness of 5/8 or 1-1/4 in. within the opening on each side of opening for a 1 or 2 hr rated assemblies, respectively. The hourly fire rating of the joint system is dependent on the hourly fire rating of the wall.
2. **Joint System Max** — width of joint (at time of installation of joint system) is 3, 4, 5 or 6 in. The joint system is designed to accommodate a max 50 percent compression, extension or vertical shear from its installed width. The joint system consists of the following:
  - A. **Mechanical Joint Assembly** — Fire barrier material encased in corrugated metal and provided with metal flanges. Assembly to be installed on either side of wall in accordance with the installation instructions provide with the product. The following assemblies are to be used with the different joint sizes:

Nom Joint Width In.	Mechanical Joint Designation
3	MFX-3W
4	MFX-4W
5	MFX-5W
6	MFX-6W

## CONSTRUCTION SPECIALTIES INC

- B. **Retaining Angles** — Min 2-1/2 by 2-1/2 in. 20 gauge (or heavier) galvanized steel angles installed over steel flanges of joint. Angles to extend entire length of joint and are to be attached to wall assembly with min 1-3/4 in. long drywall screws spaced a max of 18 in. on center.
- C. **Joint Cover** — Min 0.034 in. thick metallic cover plates secured to each side of wall, continuous over full height of joint. Cover plates attached to wall on one side of opening only with min 2-1/2 in. long drywall screws spaced a max of 18 in. on center.

\*Bearing the UL Classification Mark

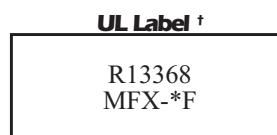

†APPLIED TO FIRE BARRIER MATERIAL

\*=NOM JOINT WIDTH

1/2006

©Copyright 2006 Construction Specialties, Inc.

**C/SGROUP**

To download details and specifications visit [www.c-sgroup.com](http://www.c-sgroup.com).  
For technical and design assistance call (800) 233-8493.