



Expansion Joint Covers

GTP-M

Technical Data:

Aluminum

- Extrusion – C/S uses multiple alloys & tempers which are established to be the most appropriate for the given use of individual parts. Will be one of the following: (6063-T5, T6, T52) (6061-T5, T6, T51) (6105-T5, T6) (6005-T5) (6005A-T5, T61)

Primary Seal

- Dual Durometer 65 Shore A, 90 Shore A, ASTM D2000
- Available in 4 colors.

Standard Loading

- 500 lbs.

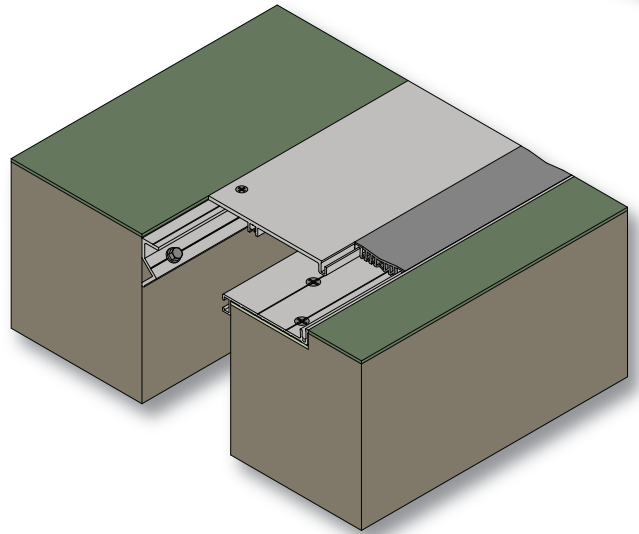

Product Description:

This gasketed flush floor cover is ideal for new to existing conditions, and where exposed metal center plate is desired.

Use This Cover For:

- Applications where a flush cover is preferred.
- Where light wheeled equipment is to be used.
- Where hygiene is important.
- New to Existing conditions.

Performance Characteristics:

The dual durometer thermoplastic gasket has rigid edges designed to lock into the aluminum side frames. This prevents hairline gaps from opening between the gasket and frame ensuring a hygienic seal. The softer center section of the gasket allows full movement without the need for grooves in the top surface which collect dirt. The rigid edges also prevent the gasket from being cut by heavy rolling loads that tend to destroy conventional gaskets. Durable aluminum plate spans joint opening.

Standard Finishes:

Mill finish. Gasket is available in Black, White, Gray, & Greige. Aluminum in contact with concrete/masonry will have a 2 mil heavy metal free high solids primer.

Installation Guidelines:

The blockouts must be prepared to receive the joint cover. Depth may be adjusted as needed to accommodate a floor finish material when required. Attach new frame in blockout and existing frame to face of slab with C/S supplied fasteners. Attach cover plate and insert gaskets. For complete installation instructions, please visit www.c-sgroup.com.

MODEL	JOINT WIDTH	MINIMUM OPENING	MAXIMUM OPENING	EXPOSED SURFACE	BLOCKOUT WIDTH	BLOCKOUT HEIGHT
GTP-200M	2.00" (51mm)	1.00" (25mm)	3.00" (76mm)	4.25" (108mm)	2.25" (57mm)	0.63" (16mm)
GTP-300M	3.00" (76mm)	1.50" (38mm)	4.50" (114mm)	6.50" (165mm)	3.50" (89mm)	0.63" (16mm)
GTP-400M	4.00" (102mm)	2.50" (64mm)	5.50" (140mm)	7.50" (191mm)	3.50" (89mm)	0.63" (16mm)

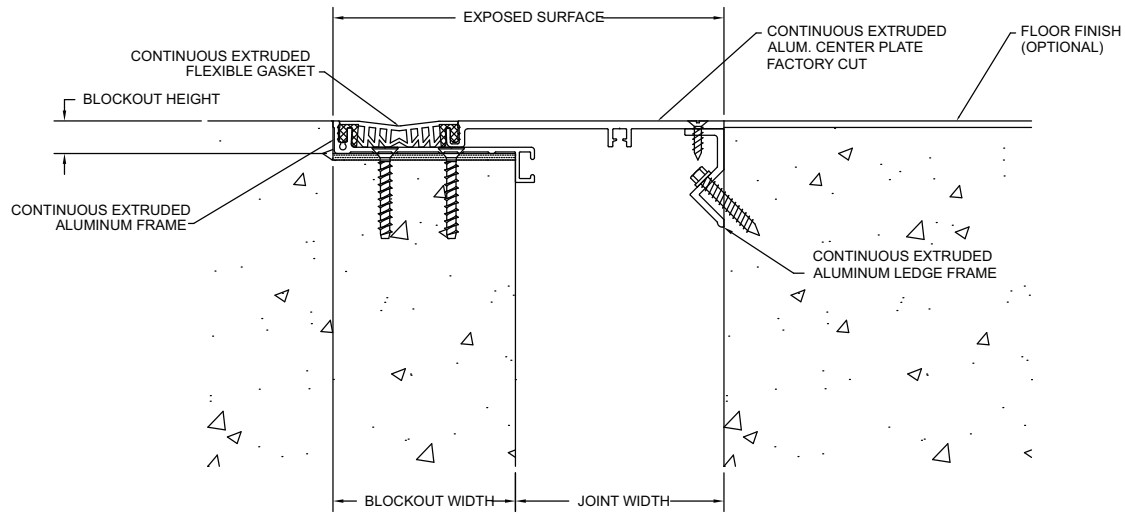

GTP-M (TYP.)