



# Expansion Joint Covers

## GFT & GFTW Series

### Technical Data:

#### Aluminum

- Extrusion – C/S uses multiple alloys & tempers which are established to be the most appropriate for the given use of individual parts. Will be one of the following: (6063-T5, T6, T52) (6061-T5, T6, T51) (6105-T5, T6) (6005-T5) (6005A-T5, T61)

#### Primary Seal

- Dual Durometer 65 Shore A, 90 Shore A, ASTM D2000
- Available in 4 colors.

#### Standard Loading

- 500 lbs.

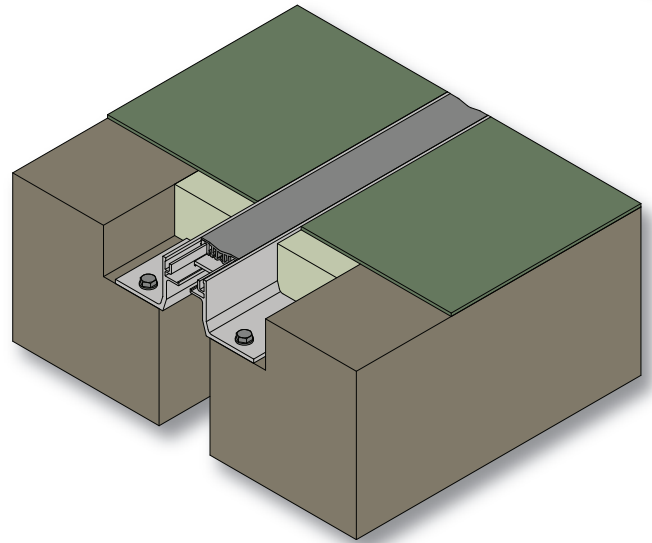

### Product Description:

GFT / GFTW is a gasketed floor joint cover comprised of extruded aluminum frames and a TPR seal. The frames are available in heights of 1", 1-1/2", 2", and 3".

### Use This Cover For:

- Applications with small, interior joints where minimal visual impact is preferred.
- Suitable for most floor finishes. Frame depth and configuration is variable to suit selected finish.
- Where wheeled equipment is to be used.
- Where hygiene is important.
- 1" and 2" joints.

### Performance Characteristics:

The dual durometer thermoplastic gasket has rigid edges designed to lock into the aluminum side frames. This prevents hairline gaps from opening between the gasket and frame ensuring a hygienic seal. The softer center section of the gasket allows full movement without the need for grooves in the top surface which collect dirt. The rigid edges also prevent the gasket from being cut by heavy rolling loads that tend to destroy conventional gaskets. 2" model includes aluminum support plate for added durability.

### Standard Finishes:

Mill finish. Gasket is available in Black, White, Gray, & Greige. Aluminum in contact with concrete/masonry will have a 2 mil heavy metal free high solids primer.

### Installation Guidelines:

The blockouts must be prepared to receive the joint cover. Depth may be adjusted as needed to accommodate a floor finish material when required. The assembly will be attached to the slab with mechanical fasteners. The remaining space in the blockouts gets filled with a high strength, non-shrink (HSNS) grout. For complete installation instructions, please visit [www.c-sgroup.com](http://www.c-sgroup.com).

To download detail, specs & photos visit [www.c-sgroup.com](http://www.c-sgroup.com)  
For technical and design assistance call 800-233-8493.

MODEL	JOINT WIDTH	MINIMUM OPENING	MAXIMUM OPENING	EXPOSED SURFACE	BLOCKOUT WIDTH	BLOCKOUT HEIGHT
GFT-100	1.00" (25mm)	0.75" (19mm)	1.25" (32mm)	1.25" (32mm)	2.50" (64mm)	VARIES
GFT-200	2.00" (51mm)	1.50" (38mm)	2.50" (64mm)	1.88" (48mm)	2.50" (64mm)	VARIES
GFTW-100	1.00" (25mm)	0.75" (19mm)	1.25" (32mm)	1.13" (29mm)	2.50" (64mm)	VARIES
GFTW-200	2.00" (51mm)	1.50" (38mm)	2.50" (64mm)	1.93" (49mm)	2.50" (64mm)	VARIES

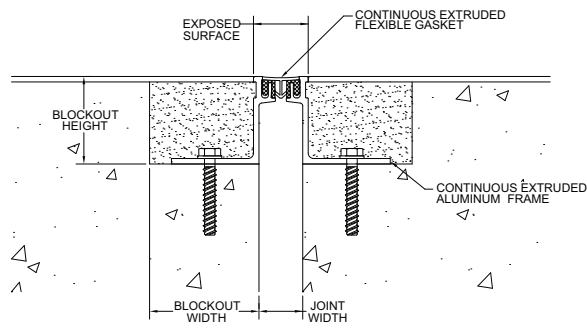

GFT-100

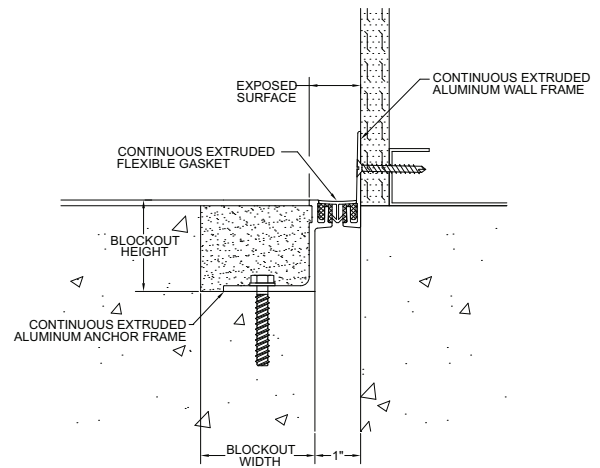

GFTW-100

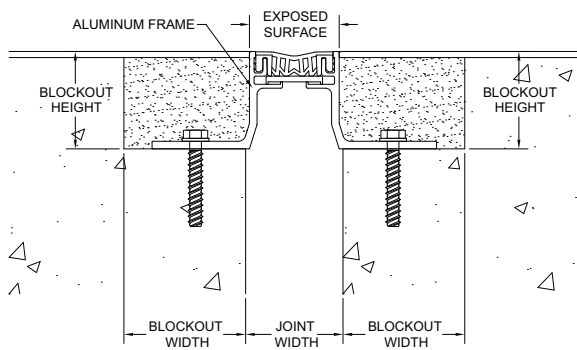

GFT-200

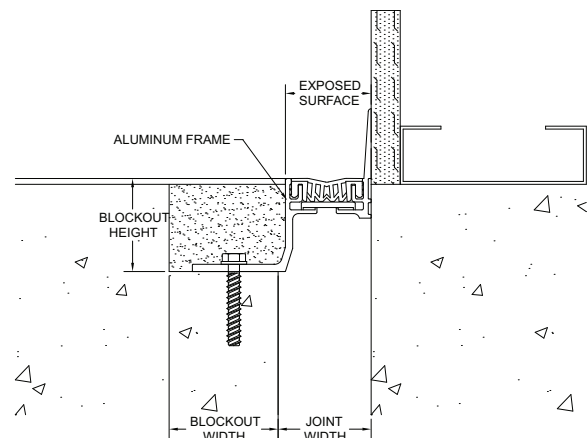

GFTW-200