



Expansion Joint Covers

GFPS & GFPSW Series

Technical Data:

Aluminum

- Extrusion – C/S uses multiple alloys & tempers which are established to be the most appropriate for the given use of individual parts. Will be one of the following:(6063-T5, T6, T52) (6061-T5, T6, T51) (6105-T5, T6) (6005-T5) (6005A-T5, T61)

Primary Seal

- Dual Durometer 65 Shore A, 90 Shore A, ASTM D2000
- Available in 4 colors.

Standard Loading

- 500 lbs.

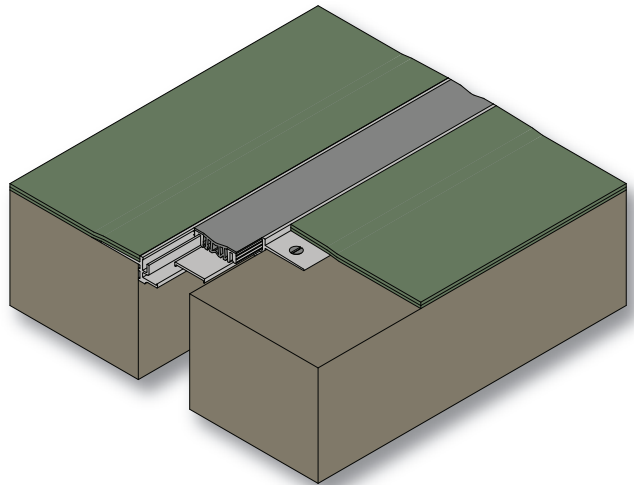

Product Description:

GFPS / GFSPW is a gasketed floor joint cover comprised of extruded aluminum frames and a TPR seal. The extruded aluminum floor frame is designed to provide a minimal bump in a surface-mounted application and accept a carpet floor finish.

Use This Cover For:

- Applications with small, interior joints where minimal visual impact is preferred.
- Suitable for carpet finishes.
- Where wheeled equipment is to be used.
- Where hygiene is important.
- 1" and 2" joints.
- Retrofit applications.

Performance Characteristics:

The dual durometer thermoplastic gasket has rigid edges designed to lock into the aluminum side frames. This prevents hairline gaps from opening between the gasket and frame ensuring a hygienic seal. The softer center section of the gasket allows full movement without the need for grooves in the top surface which collect dirt. The rigid edges also prevent the gasket from being cut by heavy rolling loads that tend to destroy conventional gaskets. 2" model includes aluminum support plate for added durability.

Standard Finishes:

Mill finish. Gasket is available in Black, White, Gray, & Greige.

Installation Guidelines:

No blockouts required. System attaches to surface of substrate by using mechanical fasteners. For complete installation instructions, please visit www.c-sgroup.com.

MODEL	JOINT WIDTH	MINIMUM OPENING	MAXIMUM OPENING	EXPOSED SURFACE	BLOCKOUT WIDTH	BLOCKOUT HEIGHT
GFPS-100	1.00" (25mm)	0.75" (19mm)	1.25" (32mm)	1.18" (30mm)	N/A	N/A
GFPS-200	2.00" (51mm)	1.50" (38mm)	2.50" (64mm)	1.88" (48mm)	N/A	N/A
GFPSW-100	1.00" (25mm)	0.75" (19mm)	1.25" (32mm)	1.09" (28mm)	N/A	N/A
GFPSW-200	2.00" (51mm)	1.50" (38mm)	2.50" (64mm)	1.94" (49mm)	N/A	N/A

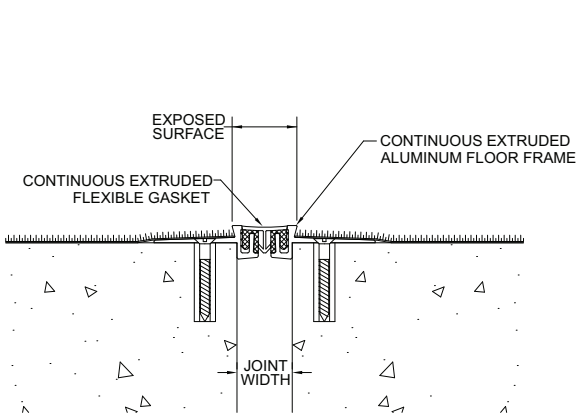

GFPS-100

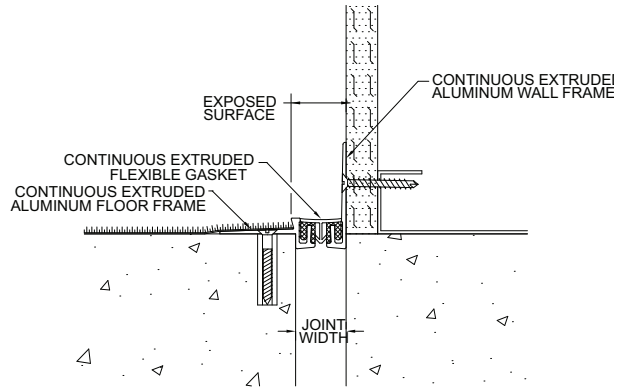

GFPSW-100

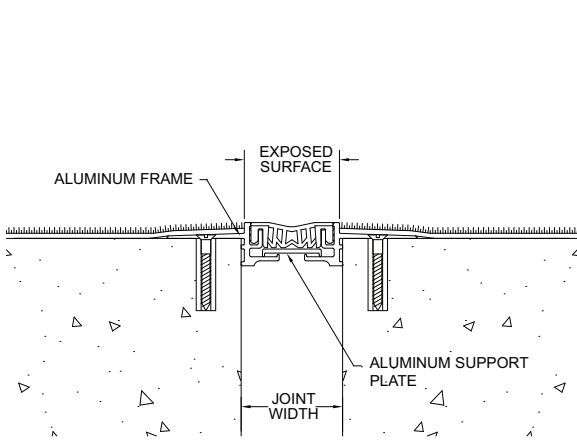

GFPS-200

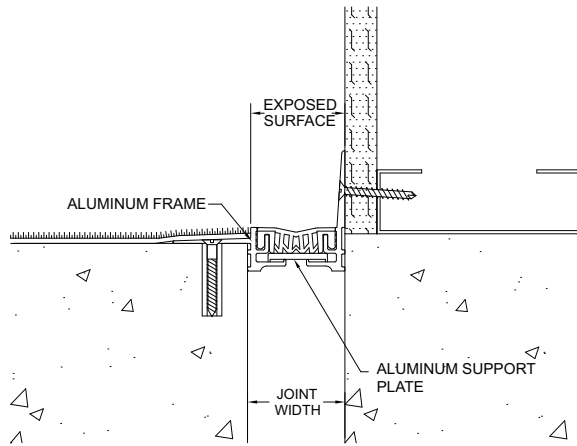

GFPSW-200