



Expansion Joint Covers

FWF & FWFC 600/1000 Series

Technical Data:

Aluminum

- Extrusion – C/S uses multiple alloys & tempers which are established to be the most appropriate for the given use of individual parts. Will be one of the following:(6063-T5, T6, T52) (6061-T5, T6, T51) (6105-T5, T6) (6005-T5) (6005A-T5, T61)

Primary Seal

- Single Durometer 70 Shore-A, ASTM D2000
- Available in 4 colors.

Product Description:

This single gasket, wall and ceiling cover is ideal for applications where minimal visual impact is preferred.

Use This Cover For:

- Suitable for G.W.B. wall and ceiling construction – retainer configuration variable to suit flat and corner applications.
- Where hygiene is important.

Performance Characteristics:

The thermoplastic gasket has edges designed to lock into the aluminum retainers. This prevents hairline gaps from opening between the gasket and retainer ensuring a hygienic seal. The center section of the gasket flexes to allow full movement. The gaskets are supported with an aluminum center mullion and turnbars (7" and larger).

Standard Finishes:

Mill finish on any exposed aluminum. Gasket is available in Black, White, Gray, & Greige.

Installation Guidelines:

Attach the aluminum retainers to the wall using mechanical fasteners. Install gasket into the retainers if not factory installed. Tape the edges of the aluminum retainer and feather drywall cement to provide a smooth transition to the drywall. Apply the appropriate wall finish as required. For the complete installation instructions, please visit www.c-sgroup.com.

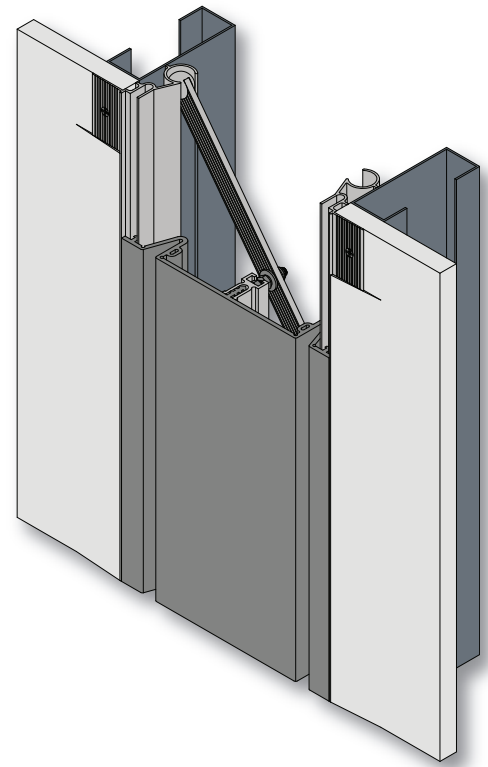

MODEL	JOINT WIDTH	MINIMUM OPENING	MAXIMUM OPENING	EXPOSED SURFACE	BLOCKOUT WIDTH	BLOCKOUT HEIGHT
FWF-600	6.00" (152mm)	1.75" (44mm)	9.00" (229mm)	6.00" (152mm)	N/A	N/A
FWF-700	7.00" (178mm)	2.50" (64mm)	10.50" (267mm)	7.00" (178mm)	N/A	N/A
FWF-800	8.00" (203mm)	2.50" (64mm)	12.00" (305mm)	8.00" (203mm)	N/A	N/A
FWF-900	9.00" (229mm)	2.50" (64mm)	13.50" (343mm)	9.00" (229mm)	N/A	N/A
FWF-1000	10.00" (254mm)	2.50" (64mm)	15.00" (381mm)	10.00" (254mm)	N/A	N/A
FWFC-600	6.00" (152mm)	1.75" (44mm)	9.00" (229mm)	6.00" (152mm)	N/A	N/A
FWFC-700	7.00" (178mm)	2.50" (64mm)	10.50" (267mm)	7.00" (178mm)	N/A	N/A
FWFC-800	8.00" (203mm)	2.50" (64mm)	12.00" (305mm)	8.00" (203mm)	N/A	N/A
FWFC-900	9.00" (229mm)	2.50" (64mm)	14.00" (356mm)	9.00" (229mm)	N/A	N/A
FWFC-1000	10.00" (254mm)	2.50" (64mm)	15.00" (381mm)	10.00" (254mm)	N/A	N/A

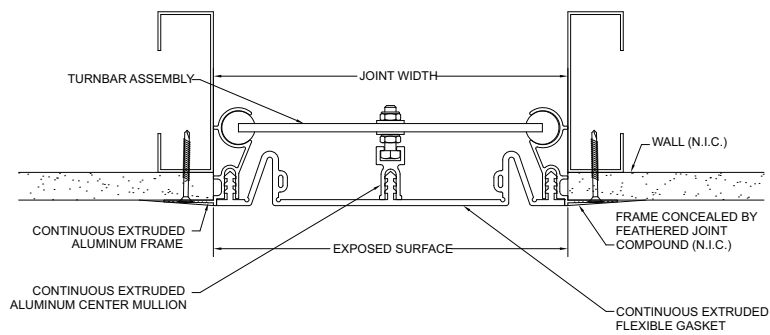

FWF-600/1000

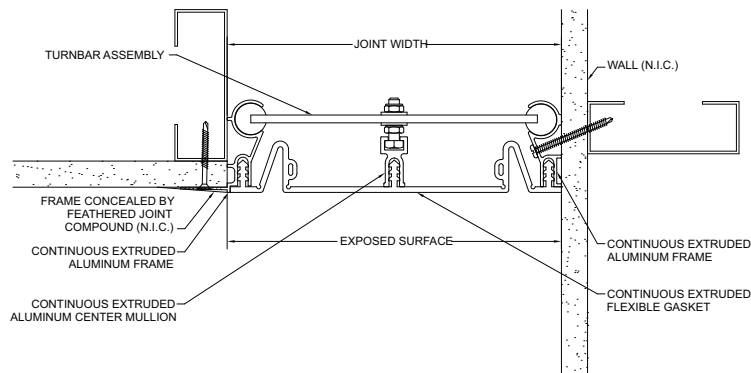

FWFC-600/1000

NOTE: No turnbar required for 6" models.