



Expansion Joint Covers

FWF & FWFC 300/500 Series

Technical Data:

Aluminum

- Extrusion – C/S uses multiple alloys & tempers which are established to be the most appropriate for the given use of individual parts. Will be one of the following:(6063-T5, T6, T52) (6061-T5, T6, T51) (6105-T5, T6) (6005-T5) (6005A-T5, T61)

Primary Seal

- Single Durometer 70 Shore-A, ASTM D2000
- Available in 4 colors.

Product Description:

This single gasket, wall and ceiling cover is ideal for applications where minimal visual impact is preferred. These models are also designed to match flush Thinline covers used in the floor.

Use This Cover For:

- Suitable for G.W.B. wall and ceiling construction – retainer configuration variable to suit flat and corner applications.
- Where hygiene is important.

Performance Characteristics:

The thermoplastic gasket has edges designed to lock into the aluminum retainers. This prevents hairline gaps from opening between the gasket and retainer ensuring a hygienic seal. The center section of the gasket flexes to allow full movement.

Standard Finishes:

Mill finish on any exposed aluminum. Gasket is available in Black, White, Gray, & Greige.

Installation Guidelines:

Attach the aluminum retainers to the wall using mechanical fasteners. Install gasket into the retainers if not factory installed. Tape the edges of the aluminum retainer and feather drywall compound to provide a smooth transition to the drywall. Apply the appropriate wall finish as required. For the complete installation instructions, please visit www.c-sgroup.com.

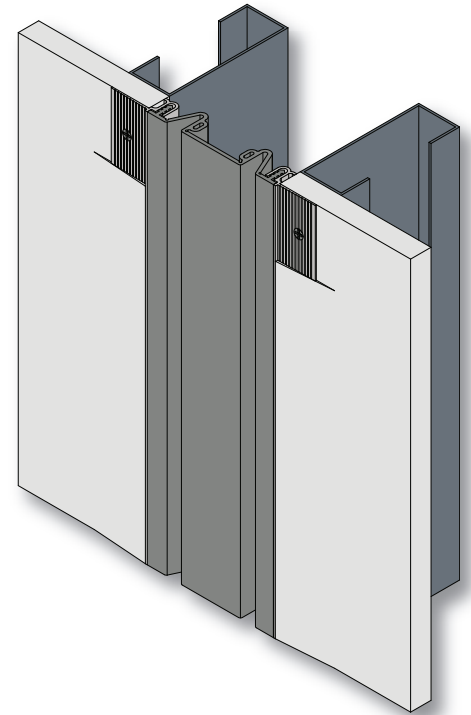

MODEL	JOINT WIDTH	MINIMUM OPENING	MAXIMUM OPENING	EXPOSED SURFACE	BLOCKOUT WIDTH	BLOCKOUT HEIGHT
FWF-300	3.00" (76mm)	1.25" (32mm)	4.50" (114mm)	3.00" (76mm)	N/A	N/A
FWF-400	4.00" (102mm)	1.25" (32mm)	6.00" (152mm)	4.00" (102mm)	N/A	N/A
FWF-500	5.00" (127mm)	1.25" (32mm)	7.50" (191mm)	5.00" (127mm)	N/A	N/A
FWFC-300	3.00" (76mm)	1.25" (32mm)	4.50" (114mm)	3.00" (76mm)	N/A	N/A
FWFC-400	4.00" (102mm)	1.25" (32mm)	6.00" (152mm)	4.00" (102mm)	N/A	N/A
FWFC-500	5.00" (127mm)	1.25" (32mm)	7.50" (191mm)	5.00" (127mm)	N/A	N/A

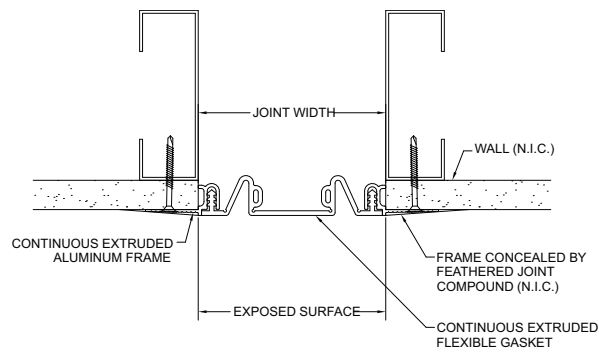

FWF-300/500

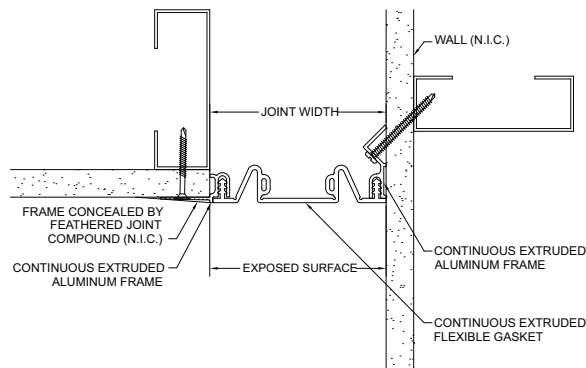

FWFC-300/500