



Expansion Joint Covers

DGTR & DGTRW Series

Technical Data:

Aluminum

- Extrusion – C/S uses multiple alloys & tempers which are established to be the most appropriate for the given use of individual parts. Will be one of the following: (6063-T5, T6, T52) (6061-T5, T6, T51) (6105-T5, T6) (6005-T5) (6005A-T5, T61)

Primary Seal

- Dual Durometer 65 Shore A, 90 Shore A, ASTM D2000
- Available in 4 colors.

Turnbar

- Injection Molded, Glass-Reinforced Plastic

Standard Loading

- 500 lbs.

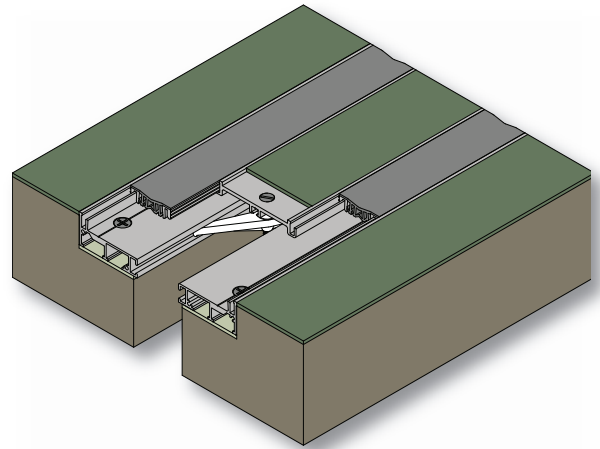

Product Description:

This dual gasket, flush floor cover uses a deep extruded aluminum base frame and is ideal for areas with larger movement requirements and where a concealed cover is desired.

Use This Cover For:

- Applications where a flush, concealed cover is preferred.
- Cover offers a 1/8" recessed center plate to accept carpet or vinyl flooring.
- Where light wheeled equipment is to be used.
- Where hygiene is important.
- Deep frame allows for more construction tolerance than shallow frames.

Performance Characteristics:

The dual durometer thermoplastic gasket has rigid edges designed to lock into the aluminum side frames. This prevents hairline gaps from opening between the gasket and frame ensuring a hygienic seal. The softer center section of the gasket allows full movement without the need for grooves in the top surface which collect dirt. The rigid edges also prevent the gasket from being cut by heavy rolling loads that tend to destroy conventional gaskets. Dual gaskets allow for greater expansion and compression during movement. Durable self-centering aluminum plate spans joint opening.

Standard Finishes:

Mill finish. Gasket is available in Black, White, Gray, & Greige. Aluminum in contact with concrete/masonry will have a 2 mil heavy metal free high solids primer.

Installation Guidelines:

The blockouts must be prepared to receive the joint cover. Depth may be adjusted as needed to accommodate a floor finish material when required. Attach frames in blockout with C/S supplied screws. Slide in turnbars and align with holes in cover plate. Screw cover plate into turnbars and insert gaskets. For complete installation instructions, please visit www.c-sgroup.com.

To download detail, specs & photos visit www.c-sgroup.com
For technical and design assistance call 800-233-8493.

MODEL	JOINT WIDTH	MINIMUM OPENING	MAXIMUM OPENING	EXPOSED SURFACE	BLOCKOUT WIDTH	BLOCKOUT HEIGHT
DGTR-200	2.00" (51mm)	1.00" (25mm)	3.75" (95mm)	6.50" (165mm)	2.25" (57mm)	1.19" (30mm)
DGTR-300	3.00" (76mm)	1.25" (32mm)	6.00" (152mm)	10.00" (254mm)	3.50" (89mm)	1.19" (30mm)
DGTR-400	4.00" (102mm)	1.25" (32mm)	6.25" (159mm)	11.00" (279mm)	3.50" (89mm)	1.19" (30mm)
DGTRW-200	2.00" (51mm)	1.00" (25mm)	3.00" (76mm)	4.25" (108mm)	2.25" (57mm)	1.19" (30mm)
DGTRW-300	3.00" (76mm)	1.50" (38mm)	4.50" (114mm)	6.50" (165mm)	3.50" (89mm)	1.19" (30mm)
DGTRW-400	4.00" (102mm)	2.50" (64mm)	5.50" (140mm)	7.50" (191mm)	3.50" (89mm)	1.19" (30mm)

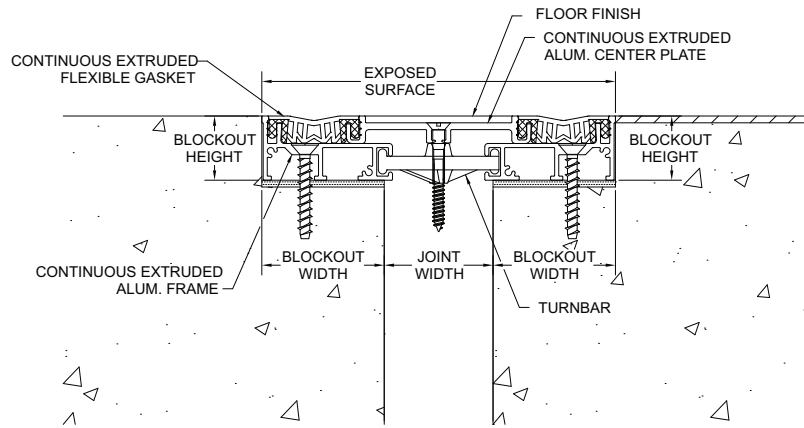

DGTR (TYP.)

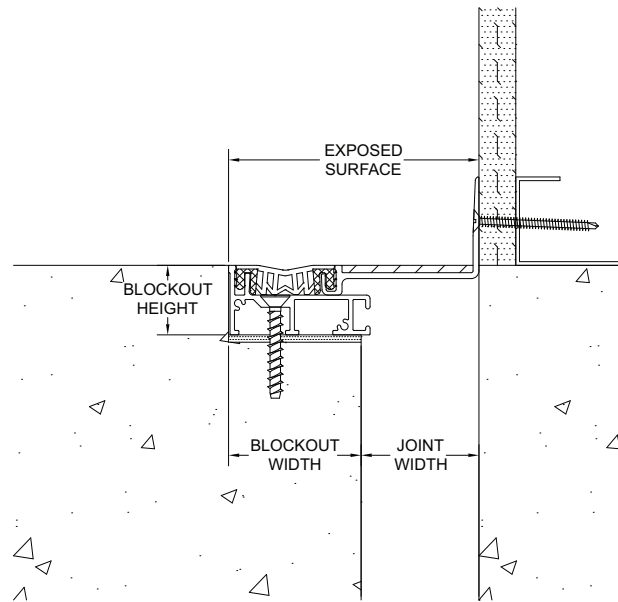

DGTRW (TYP.)