



# Expansion Joint Covers

## DGTP-HD & DGTPW-HD Series

### Technical Data:

#### Aluminum

- Extrusion – C/S uses multiple alloys & tempers which are established to be the most appropriate for the given use of individual parts. Will be one of the following: (6063-T5, T6, T52) (6061-T5, T6, T51) (6105-T5, T6) (6005-T5) (6005A-T5, T61) **Primary Seal**

- Dual Durometer 65 Shore A, 90 Shore A, ASTM D2000
- Available in 4 colors.

#### Turnbar

- Injection Molded, Glass-Reinforced Plastic

#### Standard Loading

- 2,000 lbs.

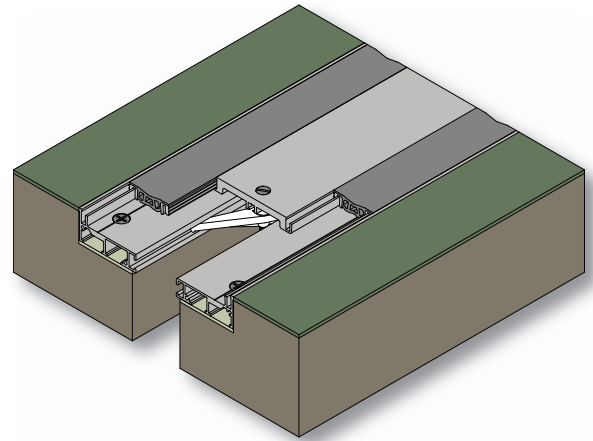

### Product Description:

This dual gasket, flush floor cover uses a deep extruded aluminum base frame and is ideal for areas where heavy rolling loads will occur and where there are larger movement requirements.

### Use This Cover For:

- Applications with larger movement requirements and where a flush, cover is preferred.
- Where heavy wheeled equipment is to be used.
- Where hygiene is important.
- Deep frame allows for more construction tolerance than shallow frames.

### Performance Characteristics:

The dual durometer thermoplastic gasket has rigid edges designed to lock into the aluminum side frames. This prevents hairline gaps from opening between the gasket and frame ensuring a hygienic seal. The rigid edges also prevent the gasket from being cut by heavy rolling loads that tend to destroy conventional gaskets. The softer center section of the gasket allows full movement. The heavy-duty gaskets are closed cell extrusions capable of heavier loads than traditional gaskets. Dual gaskets allow for greater expansion and compression during movement. Durable, self-centering aluminum plate spans joint opening.

### Standard Finishes:

Mill finish. Gasket is available in Black, White, Gray, & Greige. Aluminum in contact with concrete/masonry will have a 2 mil heavy metal free high solids primer.

### Installation Guidelines:

The blockouts must be prepared to receive the joint cover. Depth may be adjusted as needed to accommodate a floor finish material when required. Attach frames in blockout with C/S supplied screws. Slide in turnbars and align with holes in cover plate. Screw cover plate into turnbars and insert gaskets. For complete installation instructions, please visit [www.c-sgroup.com](http://www.c-sgroup.com).

To download detail, specs & photos visit [www.c-sgroup.com](http://www.c-sgroup.com)  
For technical and design assistance call 800-233-8493.

MODEL	JOINT WIDTH	MINIMUM OPENING	MAXIMUM OPENING	EXPOSED SURFACE	BLOCKOUT WIDTH	BLOCKOUT HEIGHT
DGTP-200HD	2.00" (51mm)	1.00" (25mm)	3.75" (95mm)	6.50" (165mm)	2.25" (57mm)	1.19" (30mm)
DGTP-300HD	3.00" (76mm)	1.25" (32mm)	6.00" (152mm)	10.00" (254mm)	3.50" (89mm)	1.19" (30mm)
DGTP-400HD	4.00" (102mm)	1.25" (32mm)	6.25" (159mm)	11.00" (279mm)	3.50" (89mm)	1.19" (30mm)
DGTPW-200HD	2.00" (51mm)	1.00" (25mm)	3.00" (76mm)	4.25" (108mm)	2.25" (57mm)	1.19" (30mm)
DGTPW-300HD	3.00" (76mm)	1.50" (38mm)	4.50" (114mm)	6.50" (165mm)	3.50" (89mm)	1.19" (30mm)
DGTPW-400HD	4.00" (102mm)	2.50" (64mm)	5.50" (140mm)	7.50" (191mm)	3.50" (89mm)	1.19" (30mm)

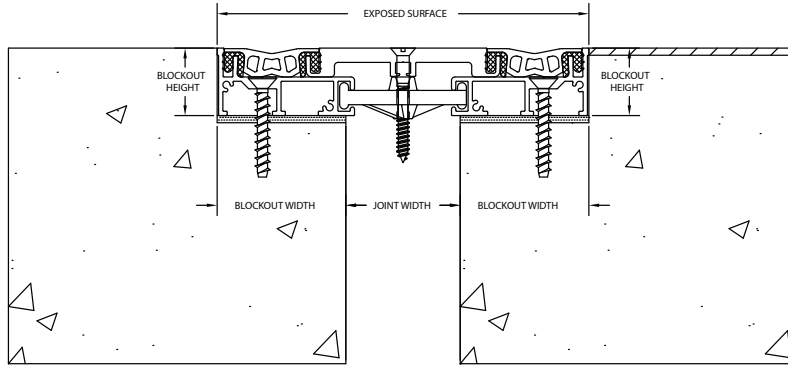

DGTP-HD (TYP.)

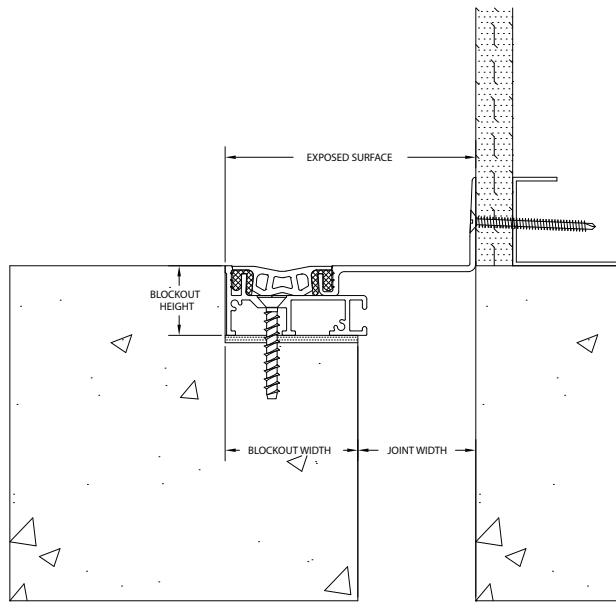

DGTPW-HD (TYP.)