



Expansion Joint Covers

ALS-M Series

Technical Data:

Aluminum

- Extrusion – C/S uses multiple alloys & tempers which are established to be the most appropriate for the given use of individual parts. Will be one of the following: (6063-T5, T6, T52) (6061-T5, T6, T51) (6105-T5, T6) (6005-T5) (6005A-T5, T61)

Standard Loading

- 500 lbs.

Product Description:

This all metal cover is ideal for new to existing conditions, where low maintenance is desirable, and for tamper-resistant applications. Ser-rated side plates create a more flush finish but impact visibility.

Use This Cover For:

- Applications where low maintenance is desirable or for tamper-resistant applications.
- Suitable for most floor finishes.
- Optional waterstop available for wet areas.
- New to Existing conditions.

Performance Characteristics:

Center plate attached to hinge style frame on one side, spans joint and slides between frame assemblies to allow movement when required.

Standard Finishes:

Mill finish. Aluminum in contact with concrete/masonry will have a 2 mil heavy metal free high solids primer.

Installation Guidelines:

The blockouts must be prepared to receive the joint cover. It is recommended that the breakout be formed a minimum of 1/8" deeper to allow the base to be leveled prior to installation of the joint cover. Apply a high-strength leveling grout to the base of the blockouts to provide a continuous, solid, flat and level base for the joint cover. (Note: The blockouts must be level across the joint opening.) Install base frames with C/S supplied fasteners. Install surface mounted frame on existing side. Hinge center plate into existing frame and snap cover plate into base frame. For complete installation instructions, please visit www.c-sgroup.com.

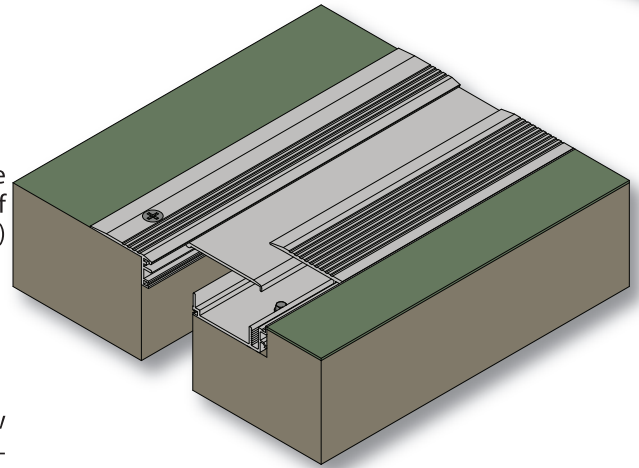

MODEL	JOINT WIDTH	MINIMUM OPENING	MAXIMUM OPENING	EXPOSED SURFACE	BLOCKOUT WIDTH	BLOCKOUT HEIGHT
ALS-100M	1.00" (25mm)	0.50" (13mm)	1.63" (41mm)	5.00" (127mm)	2.00" (51mm)	1.00" (25mm)
ALS-200M	2.00" (51mm)	1.00" (25mm)	3.00" (76mm)	6.88" (175mm)	2.88" (73mm)	1.00" (25mm)
ALS-300M	3.00" (76mm)	1.75" (44mm)	4.75" (121mm)	8.88" (225mm)	3.88" (98mm)	1.00" (25mm)
ALS-400M	4.00" (102mm)	2.50" (64mm)	5.50" (140mm)	9.88" (251mm)	3.88" (98mm)	1.00" (25mm)

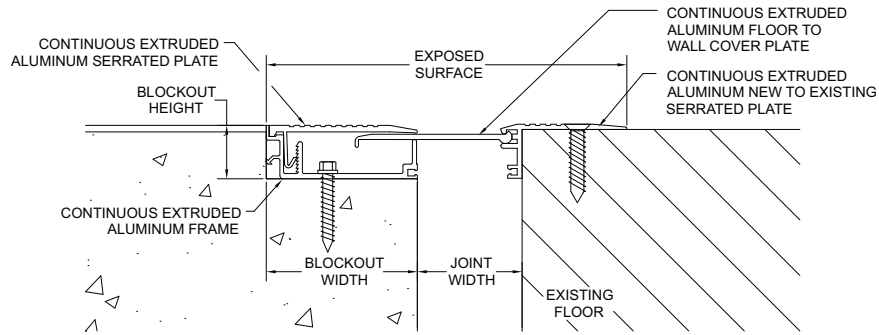

ALS-M (TYP.)