



# Expansion Joint Covers

## ALR & ALRW Series

### Technical Data:

#### Aluminum

- Extrusion – C/S uses multiple alloys & tempers which are established to be the most appropriate for the given use of individual parts. Will be one of the following: (6063-T5, T6, T52) (6061-T5, T6, T51) (6105-T5, T6) (6005-T5) (6005A-T5, T61)

#### Standard Loading

- 500 lbs.

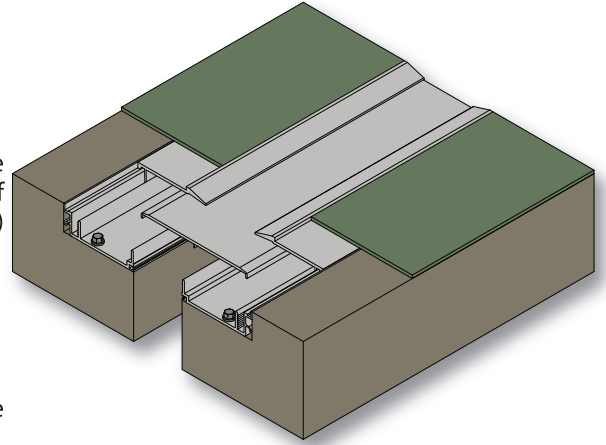

### Product Description:

This metal floor cover is designed for interior applications where low maintenance or tamper-resistant applications are desirable. With recessed side frames, this model helps reduce visual impact as compared to other metal floor covers.

### Use This Cover For:

- Interior applications where low maintenance is desirable or for tamper-resistant applications.
- Suitable for most floor finishes.
- Optional waterstop available for wet areas.

### Performance Characteristics:

Free-floating aluminum center plate spans joint and slides between frame assemblies to allow movement when required.

### Standard Finishes:

Mill finish. Aluminum in contact with concrete/masonry will have a 2 mil heavy metal free high solids primer.

### Installation Guidelines:

The blockouts must be prepared to receive the joint cover. It is recommended that the blockout be formed a minimum of 1/8" deeper to allow the base to be leveled prior to installation of the joint cover. Apply a high-strength leveling grout to the base of the blockouts to provide a continuous, solid, flat and level base for the joint cover. (Note: The blockouts must be level across the joint opening.) Install base frames with C/S supplied fasteners. Set center plate over frames and snap cover plates into base frames. For complete installation instructions, please visit [www.c-sgroup.com](http://www.c-sgroup.com).

MODEL	JOINT WIDTH	MINIMUM OPENING	MAXIMUM OPENING	EXPOSED SURFACE	BLOCKOUT WIDTH	BLOCKOUT HEIGHT
ALR-100	1.00" (25mm)	0.00" (0mm)	2.25" (57mm)	2.65" (67mm)	2.00" (51mm)	1.00" (25mm)
ALR-200	2.00" (51mm)	0.00" (0mm)	4.00" (102mm)	3.65" (93mm)	2.88" (73mm)	1.00" (25mm)
ALR-300	3.00" (76mm)	0.88" (22mm)	6.00" (152mm)	5.44" (138mm)	3.88" (98mm)	1.00" (25mm)
ALR-400	4.00" (102mm)	0.88" (22mm)	7.00" (178mm)	6.44" (164mm)	3.88" (98mm)	1.00" (25mm)
ALRW-100	1.00" (25mm)	0.50" (13mm)	1.69" (43mm)	1.81" (46mm)	2.00" (51mm)	1.00" (25mm)
ALRW-200	2.00" (51mm)	1.00" (25mm)	3.00" (76mm)	2.81" (71mm)	2.88" (73mm)	1.00" (25mm)
ALRW-300	3.00" (76mm)	1.44" (37mm)	4.56" (116mm)	4.19" (106mm)	3.88" (98mm)	1.00" (25mm)
ALRW-400	4.00" (102mm)	2.44" (62mm)	5.50" (140mm)	5.19" (132mm)	3.88" (98mm)	1.00" (25mm)

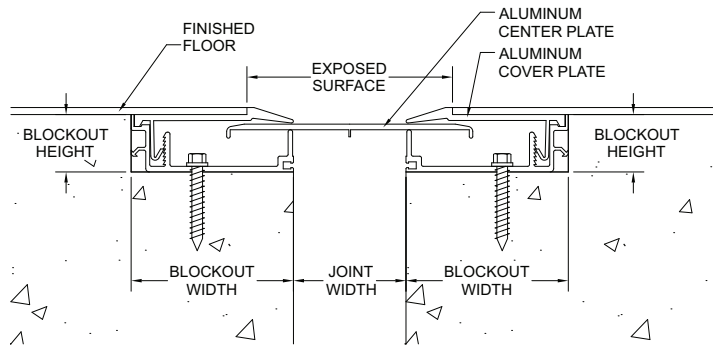

ALR (TYP.)

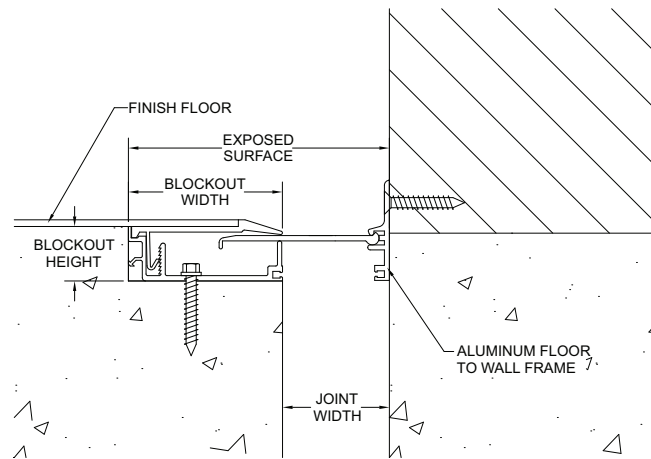

ALRW (TYP.)