



Expansion Joint Covers

AL-HDM Series

Technical Data:

Aluminum

- Extrusion – C/S uses multiple alloys & tempers which are established to be the most appropriate for the given use of individual parts. Will be one of the following:(6063-T5, T6, T52) (6061-T5, T6, T51) (6105-T5, T6) (6005-T5) (6005A-T5, T61)

Standard Loading

- 2,000 lbs.

Product Description:

This metal floor cover is designed for new to existing applications where low maintenance is desirable and heavy-duty rolling loads are expected.

Use This Cover For:

- Applications where low maintenance is desirable.
- Heavy-duty expansion joint applications.
- Suitable for most floor finishes.
- Optional waterstop available for wet areas.
- New to Existing conditions.

Performance Characteristics:

Center plate attached to hinge style frame on one side, spans joint and slides between frame assemblies to allow movement when required.

Standard Finishes:

Mill finish. Aluminum in contact with concrete/masonry will have a 2 mil heavy metal free high solids primer.

Installation Guidelines:

The blockouts must be prepared to receive the joint cover. It is recommended that the blockout be formed a minimum of 1/8" deeper to allow the base to be leveled prior to installation of the joint cover. Apply a high-strength leveling grout to the base of the blockouts to provide a continuous, solid, flat and level base for the joint cover. (Note: The blockouts must be level across the joint opening.) Install base frames with C/S supplied fasteners. Install surface mounted frame on existing side. Hinge center plate into existing frame and screw cover plate into base frame. It is recommended that polystyrene block and sealant (by others) be installed to help seal the edges at the blockout. For complete installation instructions, please visit www.c-sgroup.com.

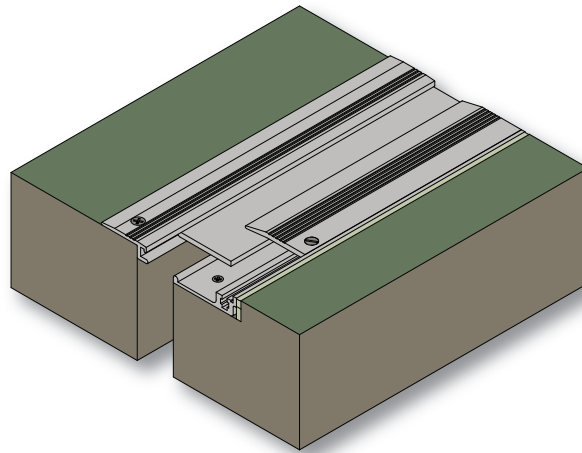

MODEL	JOINT WIDTH	MINIMUM OPENING	MAXIMUM OPENING	EXPOSED SURFACE	BLOCKOUT WIDTH	BLOCKOUT HEIGHT
AL-100HDM	1.00" (25mm)	0.13" (3mm)	2.25" (57mm)	8.75" (222mm)	4.75" (121mm)	0.75" (19mm)
AL-200HDM	2.00" (51mm)	0.63" (16mm)	3.25" (83mm)	9.25" (235mm)	4.25" (108mm)	0.75" (19mm)
AL-300HDM	3.00" (76mm)	1.50" (38mm)	4.38" (111mm)	10.25" (260mm)	4.25" (108mm)	0.75" (19mm)
AL-400HDM	4.00" (102mm)	2.50" (64mm)	5.38" (137mm)	11.25" (286mm)	4.25" (108mm)	0.75" (19mm)

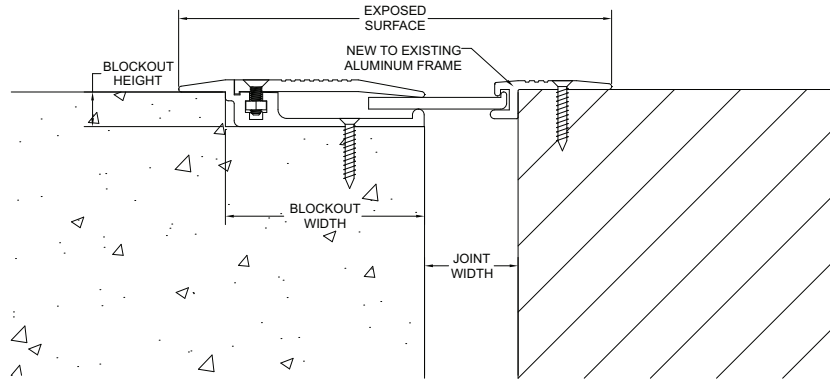

AL-HDM (TYP.)