

CONTINUOUS EXTRUDED
ALUMINUM CENTER MULLION
(12A340001)

CONTINUOUS EXTRUDED
ALUMINUM FRAME
(12A350008)

CONTINUOUS EXTRUDED
FLEXIBLE GASKET
(12V157xxx)

FRAME CONCEALED BY
FEATHERED JOINT
COMPOUND (N.I.C.)

17" TURNBAR ASSEMBLY
18"o.c.(12F150005)

10"

WALL (N.I.C.)

#6x1 5/8" TEK
SCREW 18"o.c.
(90H079002)

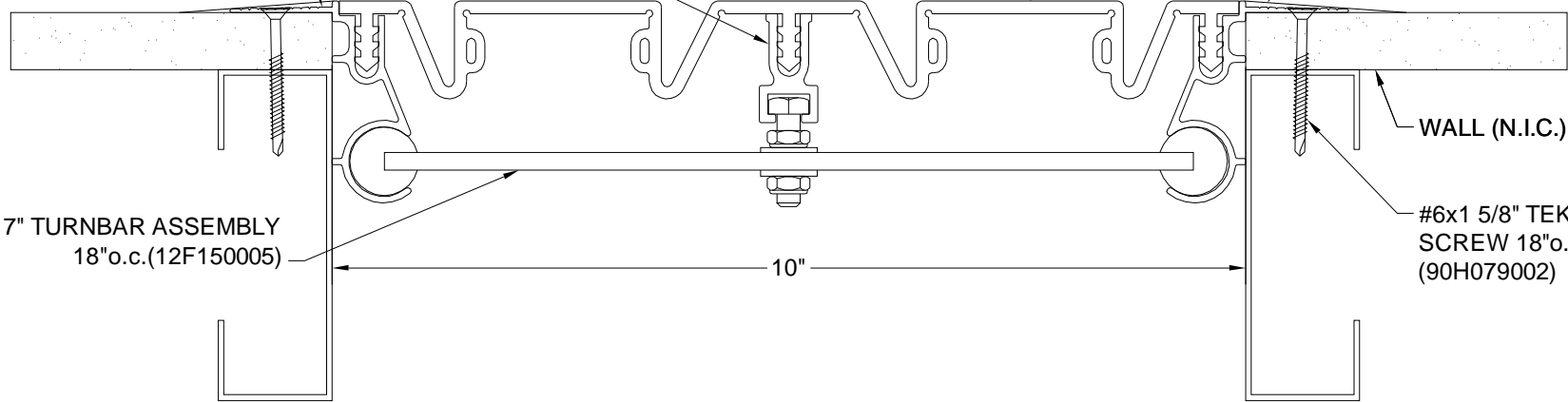

FWF-1000



Construction Specialties™

6696 Route 405 Highway, Muncy, PA 17756
Phone (800) 233-8493 / Fax (570) 546-8022

PROJECT:

SCALE:

SCALED TO FIT

CUSTOMER:

DATE:

LOCATION:

JOB NO.:

DRAWN BY:

SHEET NO.: