

# Installation Instructions

## Gridline G6 with LB Frame

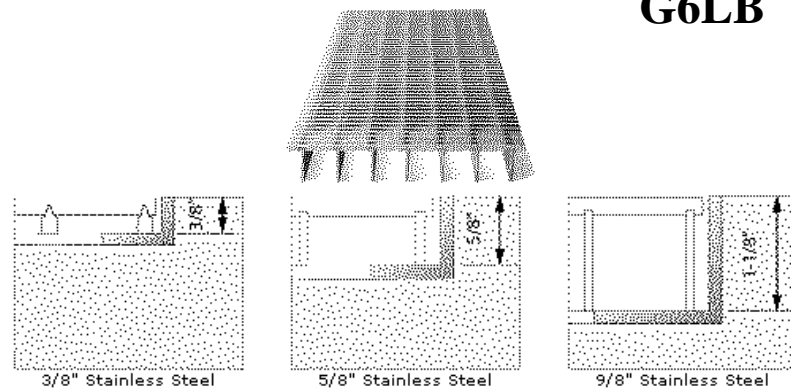

### 1). Site Prep

- Use wood forms to prepare a recess in the concrete a minimum of 1-1/4" for 1-1/8" Grille, 3/4" for 5/8" Grille and 1/2" for 3/8" Grille depth to final finished floor surface.
- Recess should be made to overall size of unit, plus a 1/16" on all sides of the recess to allow for clearance.
- Ensure the frames exposed surface will be flush with the finished floor.
- After concrete has cured, remove the wood forms.
- (See Illustration A) below

### 2). Assemble Frame

- Assemble the level base frame. The ends of the frame pieces have been mitered, pre-drilled and countersunk to allow for quick assembly.

### 3). Set Frame

- Set the frame assembly around the perimeter of the formed recess. (Illustration A)
- Shim the frame as required 24" o.c. to elevate the frame assembly to finished floor height.
- Before fastening, double check the finished floors surface height, and ensure that frame assembly is both plumb and square.
- Drill a hole using the 5/32" masonry bit into concrete using the pre-countersunk holes in the frame.
- Install 3/16" masonry anchor. (anchors and bit included in hardware package)
- Clean the concrete recess to remove all dirt, oily film, and debris.

Illustration A

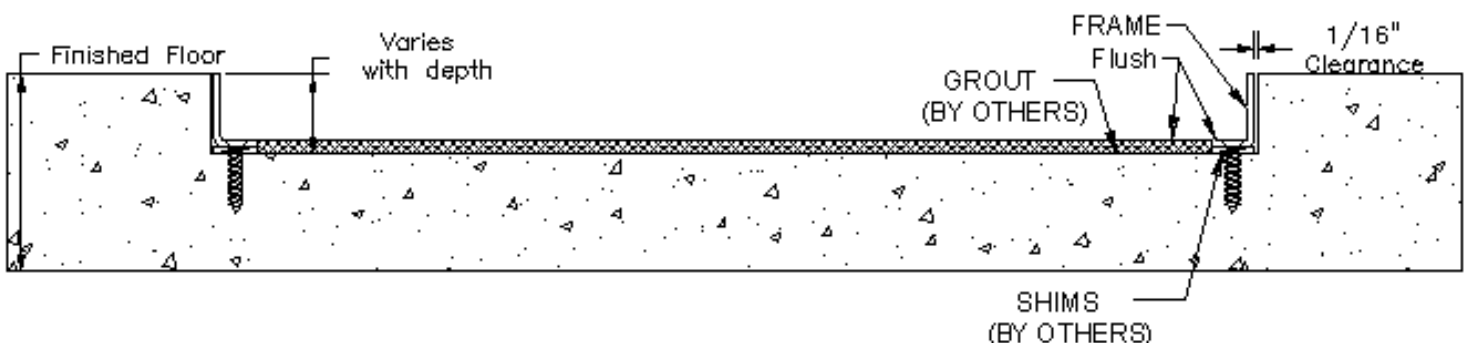

## 4). Grout

- Grout the concrete pit surface to bring bottom of recess flush with top of lower frame leg using a waterproof self-leveling grout.(Illustration B)
- Recommended brands:
  - ◆ Quikrete #1585 mixed with #8610 Acrylic Fortifier  
For technical assistance, call [Quikrete @ 800-282-5828](tel:800-282-5828), [www.quikrete.com](http://www.quikrete.com)
  - ◆ VinylCrete with Acrylic Fortifier  
For technical assistance, call [UMACO Inc @ 978-453-8881](tel:978-453-8881) [www.umaco.com](http://www.umaco.com)
- Pour and level grout using the legs within the frame opening as screed points.

**IMPORTANT: THE BED SURFACE MUST BE SMOOTH AND LEVEL TO ENSURE PROPER GRID INSTALLATION, ALIGNMENT AND TO PREVENT TRIPPING HAZARDS.**

Illustration B

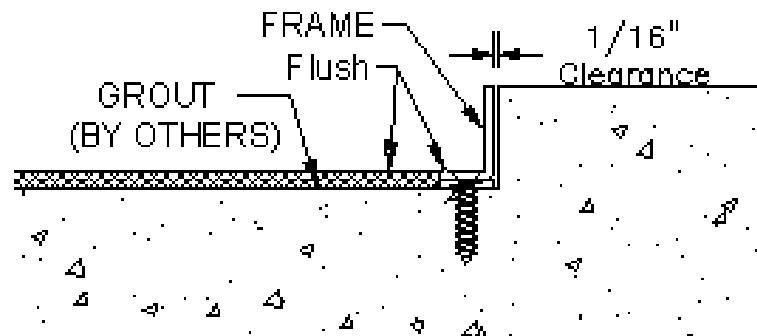

*\* Allow the grout material sufficient time to cure properly before inserting the Gridline within the framed opening.*

## 5.) Gridline Installation

- Trial fit the Gridline modules at locations indicated on shop drawings within the frames, so each module is aligned and evenly spaced between perimeter frames and adjacent modules. Mark all lock down fastener locations on the pit surface and on the grid modules then remove all grid modules. Drill all fastener holes at marked locations. (Note: surface lockdowns – 9/16” hole at 1-5/8” depth or hidden lockdowns- 3/8” hole at 5/8” depth). Install lead anchors. (Note: Use one of the screws to tighten the lead shield before installing the grids) Attach all hidden lock down clips with cap screw, flat washer and retaining washers attached to the gridline module at marked locations. Repeat for all modules. Replace all modules at intended locations.
- Use the 1/8” Hex tool (hidden lockdown) or Phillips drive (surface lockdown) to start each fastener into each expansion anchor. Once all are engaged, snug all fasteners tight. Starting from the center working out towards the perimeter in a rotating manner. Repeat for all modules. See illustration C1 for Surface Lockdowns and Illustration C2 for Hidden Lockdowns.

Illustration C1

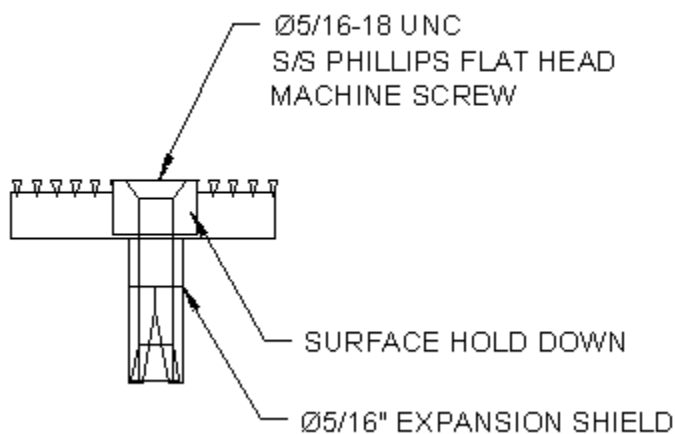
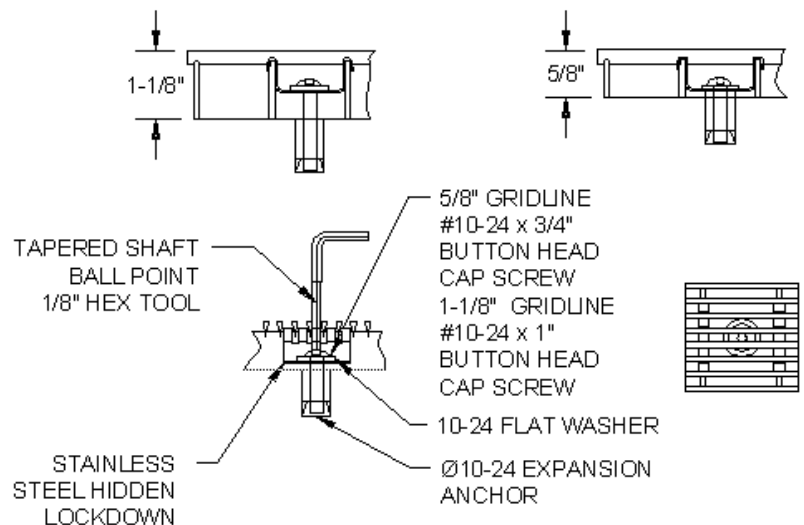

Illustration C2



## 6.) Completion

It is necessary to cover the installation with ¾” plywood until all additional project work is completed. This will protect the Gridline from potential abuse during the construction phase. Damage occurring from inadequate protection during this phase may void the manufacturer’s warranty.

## 7.) Care and Maintenance Instructions

- **Manufacturer’s suggested safe rolling load for the Gridline G6 is 500# per wheel. Heavy loads beyond this weight may damage the units, contributing to their premature failure or creating a tripping hazard.**
- **Clean the recess as frequently as necessary. This will prevent an excess buildup of dirt under the grids.**
- **Clean the grids, when cleaning the recess, using a power sprayer to wash and clean each module. Remove all clogged or caked materials from within all aperture openings.**
- **Replacement of the gridline modules, Replace each module to original position and engage all fasteners prior to final tightening of each fastener. Cleaning enables Gridline to function as intended. Call us at (800) 233-8493 (Muncy) or (888) 895-8955 (Canada) and our sales group will assist you with special needs or conditions, loading considerations and installation related issues.**



**Construction Specialties™**

[www.c-sgroup.com](http://www.c-sgroup.com)

U.S.A. 800-233-8493

Canada 888-895-8955