

Installation Instructions

Pedigrid G1 with Deep Pit Option # 1 W/ Drain Pan, & No Pan Frame

1). Site Prep

- Use wood forms to prepare a recess in the concrete a 2-3/4" depth to final finished floor surface.
- For DP frames the recess must be flat, NP recesses may be sloped
- Recess should be made to overall size of unit, plus a 1-1/2" on all sides of the recess to allow for clearance.
- Ensure the DP frames exposed surface will be flush with the finished floor.
- Locate the 2" drainpipe and trap while pouring concrete, Install drain bottom and pipe.
- Make a hole in the drain pan to accommodate the drain.
- After concrete has cured, remove the wood forms.
- (See Illustration B) below

2). Assemble Frame

- Large units will be shipped knocked down for field assembly.(See Illustration A)

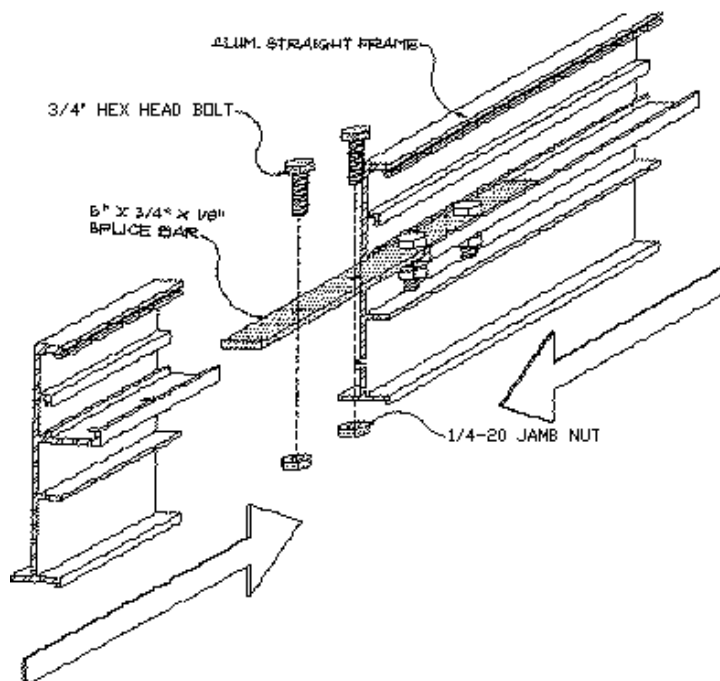
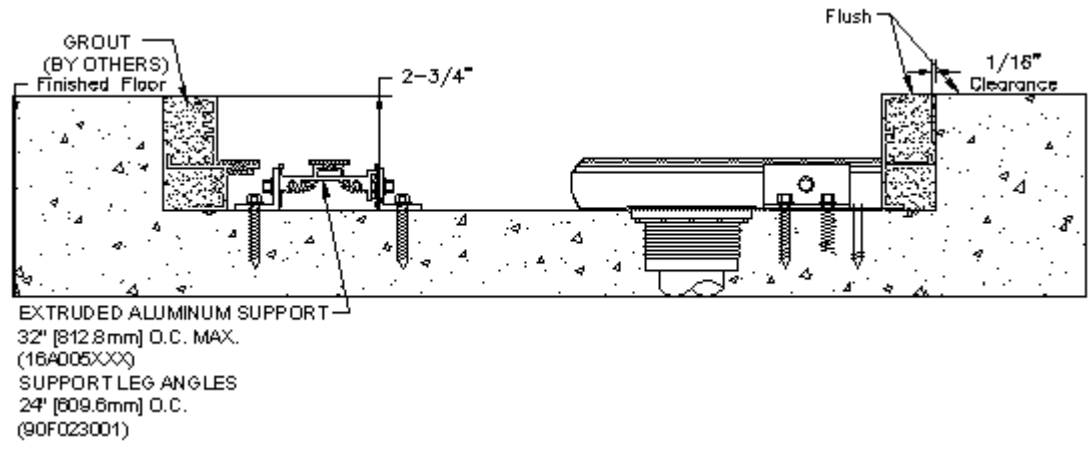

Illustration A

3). Set Frame

- Set the frame assembly in the formed recess. (See Illustration B)
- Shim the frame as required 24" o.c. to elevate the frame assembly to finished floor height.
 - Irregular shaped grids require a trial fit within frame assembly prior to anchoring frames to ensure correct frame location
- Before fastening, double check the finished floor surface height, and ensure that frame assembly is both plumb and square.
 - If necessary brace the frames to ensure they will remain parallel and square during grouting.
- Clean the concrete recess to remove all dirt, oily film, and debris.

Illustration B



4). Grout

- Grout the concrete pit surface to bring bottom of recess flush with top of lower frame leg using a waterproof self-leveling grout.(See Illustration B)
- Recommended brands:
 - ◆ Quikrete #1585 mixed with #8610 Acrylic Fortifier
For technical assistance, call [Quikrete @ 800-282-5828, www.quikrete.com](http://www.quikrete.com)
 - ◆ VinylCrete with Acrylic Fortifier
For technical assistance, call [UMACO Inc @ 978-453-8881 www.umaco.com](http://www.umaco.com)
- Pour and level grout using the legs within the frame opening as screed points.
- For drain pan applications grout only to height of shims. Installed frames will allow a void between interior frame legs. Apply loose sheets as laid out on shop fabrication drawings into remaining void.
 - All sheets must be adhered to substrate with a silicon caulk. Apply sufficient bead of caulk at joints to provide a moisture seal.

Important: the bed surface must be smooth and level to ensure proper grid installation, alignment and to prevent tripping hazards.

Allow the grout material sufficient time to cure properly before inserting the Pedigrid within the framed opening.

5.) Pedigrid Installation

- The grid(s) are now installed within the frame by laying them into their proper position by section if applicable, with the rails running perpendicular to the walking direction. (See Illustration D)
- Max grid module size is 144”wide x 36”traffic direction.

If applicable, odd shaped grids will be labeled according to the layout provided with the shop drawings.

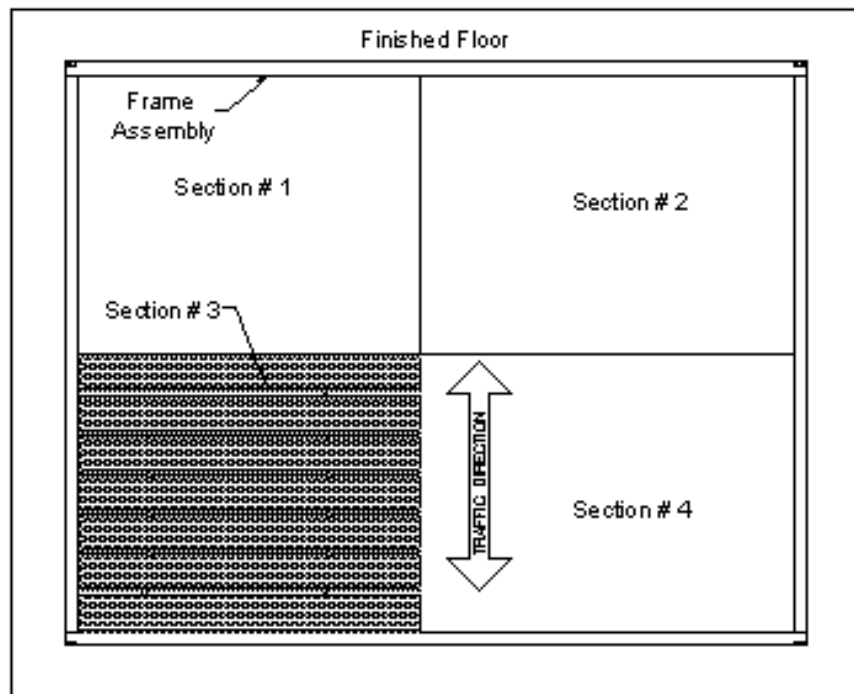

Illustration C

6.) Completion

It is necessary to cover the installation with 3/4” plywood until all additional project work is completed. This will protect the Pedigrid from potential abuse during the construction phase. Damage occurring from inadequate protection during this phase may void the manufacturer’s warranty.

7.) Cleaning and Maintenance Instructions for Pedisystems.

- **Manufacturer's suggested safe rolling load for the Pedigrid G1 is 300# per wheel**
- **Heavy loads beyond this weight may damage the units, contributing to their premature failure or creating a tripping hazard.**
- **Vacuum surface regularly with beater brush attachment to allow contact with various surfaces of entrance flooring.**
- **Before deep cleaning the surface, roll unit back to remove dirt collected underneath as needed. Dirt should be removed with professional vacuum cleaner and should not be allowed to build up to the point where a level mat surface is affected.**
- **Deep clean quarterly, either by removing unit to an area where it can be cleaned with a powerwasher (on light setting to avoid carpet damage) or.**
- **Shampoo the unit in place (soap/water extraction)**
 - **It is recommended that shampooing take place overnight to allow carpet fibers to dry thoroughly before heavy traffic resumes.**
 - **Suggestions for pre-treating the area prior to shampooing**
 - **Remove gum or other sticky substance by applying a commercial freeze spray to the affected area. This should allow the residue to break off easily.**
 - **For ground-in dirt showing in high traffic areas, add one cup of bleach per gallon of warm water and use stiff brush to pre-treat carpet fibers.**
 - **If aluminum needs cleaned, use stiff nylon bristle brush to clean with shampoo mixture prior to shampooing entire unit.**
 - **To achieve the most effective suction of the shampooer, run the wand perpendicular to the rails and not along the length of the carpet strips.**
- **Take care when mopping surrounding floor area. Keep mop away from mat or grid. The aggressive texture of the carpet inserts may grab lint when the mop comes in contact, potentially causing unsightly lint collection at edges of unit.**
- **Replacement inserts are available: See www.pedisystems.com or call 1-570-546-5941 for more information and for contact information for your local representative.**



Construction Specialties™

www.c-sgroup.com

U.S.A. 800-233-8493

Canada 888-895-8955