

PEDITRED SA WITH TAPERED ANGLE FRAME

INSERT STYLE: PEDITRED SA

INSERT COLOR:

CATALOG NUMBER: G7

PART NUMBER:

NO.	REVISION	DATE	BY
NO.	F&F RELEASE	DATE	BY

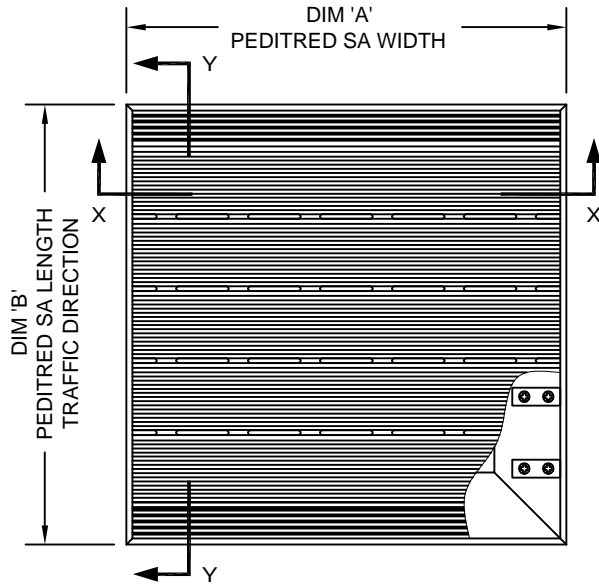

TYPICAL PLAN VIEW

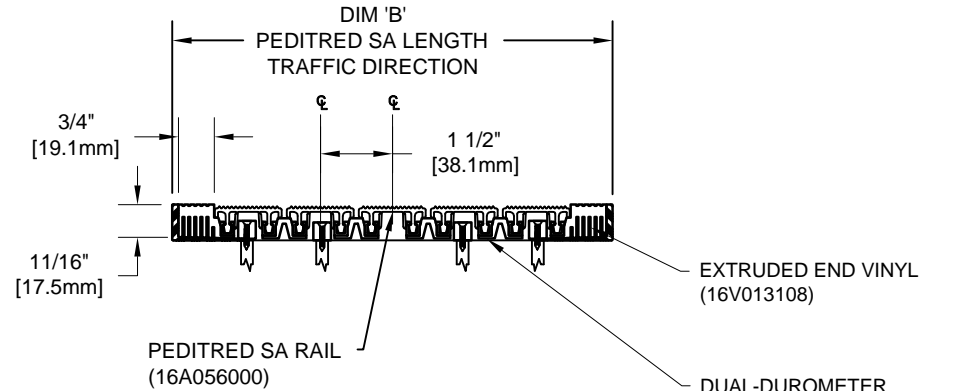

SECTION Y-Y

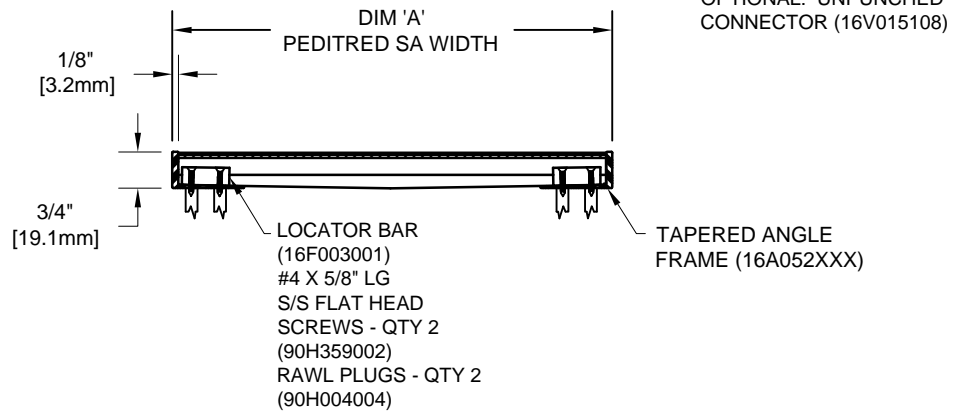

SECTION X-X

NOTES:

*ALL SURFACES IN CONTACT WITH MASONRY ARE TO RECEIVE A COAT OF ZINC CHROMATE PRIMER

*MAX. SINGLE GRID SIZE NOT TO EXCEED 12'-0" (3.66M) IN WIDTH (DIM "A")

*ADDITIONAL SPECIFICATIONS ARE CONTAINED IN THE LATEST C/S CATALOG OR AT C-SGROUP.COM AND ARE CONSIDERED PART OF THIS TRANSMITTAL.

*PLEASE VERIFY TRAFFIC DIRECTION

*DUE TO 1-1/2" MODULE OF PEDITRED SA, INSIDE OF FRAME DIMENSION SHOULD BE CHANGED ONLY IN INCREMENTS OF 1-1/2" [38.10mm] TO AVOID THE USE OF EXTRUDED END VINYL.

*SUPPLIED IN STANDARD MILL FINISH. (OPTIONAL FINISHES AVAILABLE AT ADDITIONAL COST)

*PEDITRED SA SHALL BE ABLE TO SUPPORT A 1000 LB. ROLLING LOAD. LARGER LOADING MAY BE ACCOMMODATED. CONTACT C/S SALES WITH SPECIFIC LOADING REQUIREMENTS.

Construction Specialties, Inc.



PLEASE VERIFY ALL	QTY	MARK #	LOCATION	MODEL	DIM 'A' WIDTH	DIM 'B' TRAFFIC DIR	FINISH	NOTES

PROJECT:		
LOCATION:		
CONTRACTOR:		
AGENT:		SHT:
DRG. BY:	DATE:	JOB NO.: