

PEDIGRID WITH DRAIN PAN

INSERT STYLE: INSERT COLOR: CATALOG NUMBER: G1 PART NUMBER:

NO.	REVISION	DATE	BY
NO.	F&F RELEASE	DATE	BY

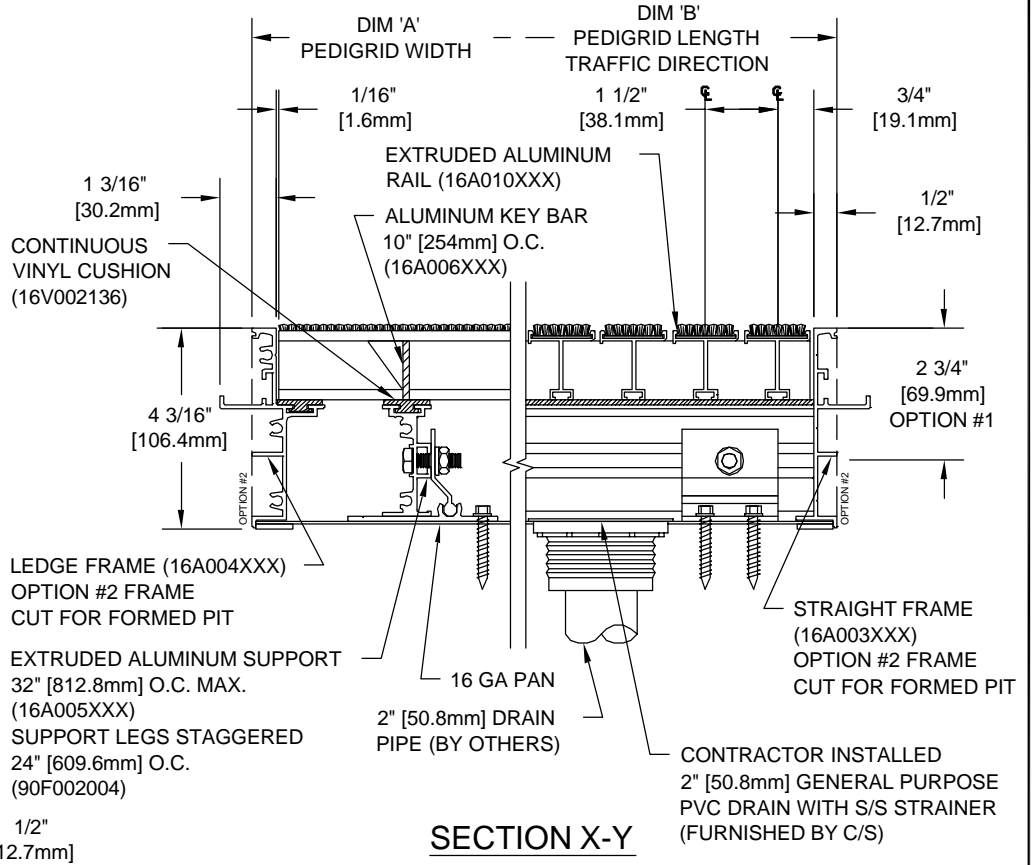
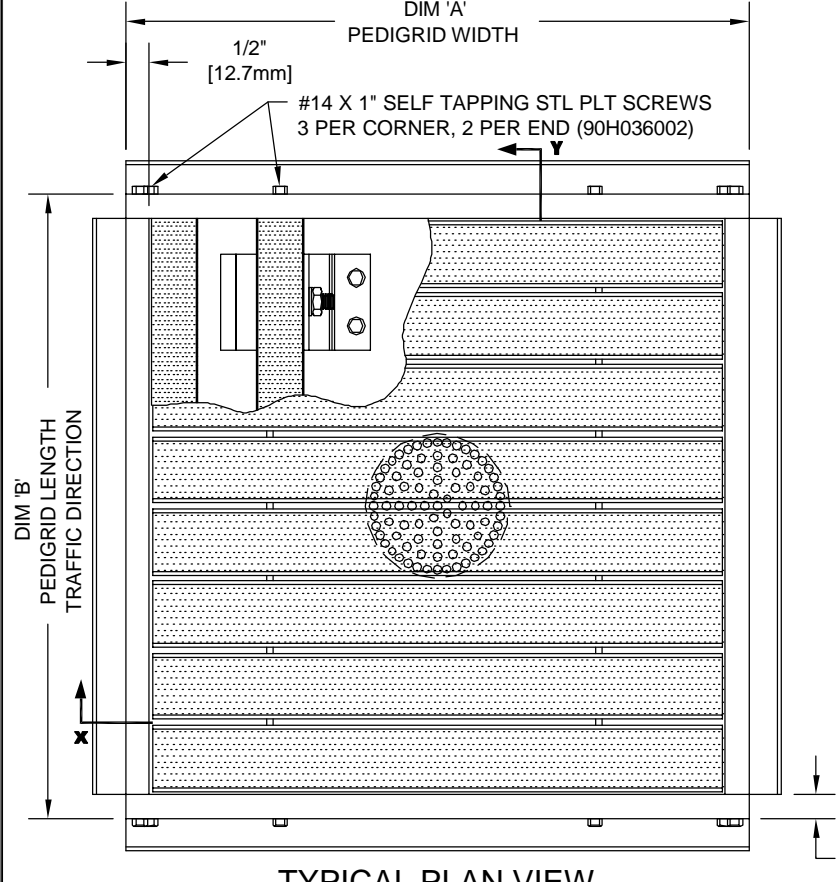
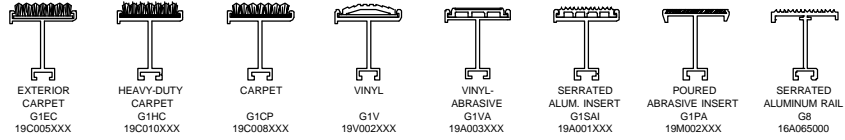

NOTES:

*GRIDS OVER STRUCTURES @ 32" O.C. TO SUPPORT A MAX LOAD OF 400 LBS PER SQ. FT. ALL GRIDS WITH LEVEL BASE FRAME TO SUPPORT A 400 LB. ROLLING LOAD. LARGER LOADING MAY BE ACCOMMODATED. CONTACT C/S SALES WITH SPECIFIC LOADING REQUIREMENTS.

*PLEASE VERIFY TRAFFIC DIRECTION.

*MAXIMUM SINGLE GRID SIZE NOT TO EXCEED 12'-0" [3.6M] IN WIDTH (DIM "A").

*ALL SURFACES IN CONTACT WITH MASONRY ARE TO RECEIVE A COAT OF ZINC CHROMATE PRIMER.

*MITERED FRAME CORNERS ARE NOT AVAILABLE.

*WITH OPTION #2, THE ANCHOR LEG IS CUT OFF TO ALLOW FOR MOUNTING IN A FORMED PIT.

*DUE TO 1 1/2" MODULE OF PEDIGRID, INSIDE OF FRAME DIMENSION SHOULD BE CHANGED ONLY IN INCREMENTS OF 1 1/2" [38.1mm] TO AVOID THE USE OF FILLER BARS.

*ADDITIONAL SPECIFICATIONS ARE CONTAINED IN THE LATEST C/S CATALOG OR AT C-SGROUP.COM AND ARE CONSIDERED PART OF THIS TRANSMITTAL.



PLEASE VERIFY ALL	QTY	MARK #	LOCATION	MODEL	DIM 'A' WIDTH	DIM 'B' LENGTH	FINISH	REMARKS

PROJECT:		
LOCATION:		
CONTRACTOR:		
AGENT:		SHT:
DRG. BY:	DATE:	JOB NO.: