

NOTE: MATERIAL MUST REACH 65°F MIN TO 75°F MAX 24 HOURS PRIOR TO INSTALLATION. THIS IS ESSENTIAL TO MINIMIZE EXPANSION AND CONTRACTION OF THE MATERIAL.

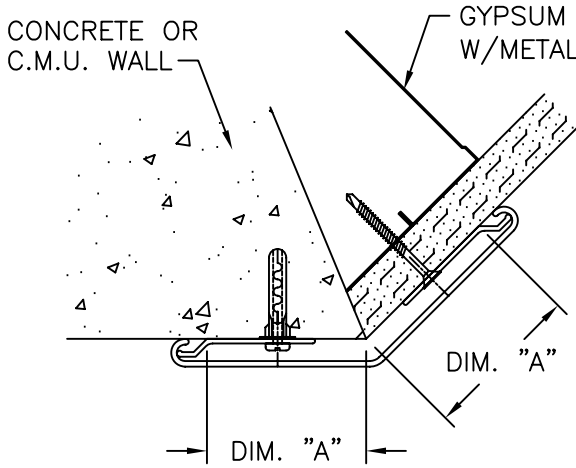

SM-20M

ANGLE	DIMENSION "A"		
	DECIMAL INCHES	FRACTIONAL INCHES	MILLIMETERS
45°	1.657	1 21/32	42.088
50°	1.748	1 3/4	44.399
55°	1.830	1 53/64	46.482
60°	1.900	1 29/32	48.260
65°	1.970	1 31/32	50.038
70°	2.020	2 1/64	51.308
75°	2.052	2 3/64	52.121
80°	2.086	2 5/64	52.984
85°	2.110	2 7/64	53.594
90°	USE STANDARD RETAINER		
95°	2.126	2 1/8	54.000
100°	2.132	2 9/64	54.153
105°	2.154	2 5/32	54.712
110°	2.182	2 3/16	55.423
115°	2.219	2 7/32	56.363
120°	2.241	2 1/4	56.921
125°	2.265	2 17/64	57.531
130°	2.285	2 9/32	58.039
135°	2.300	2 5/16	58.420
140°	2.310	2 5/16	58.674
145°	2.318	2 21/64	58.877
150°	2.325	2 21/64	59.055

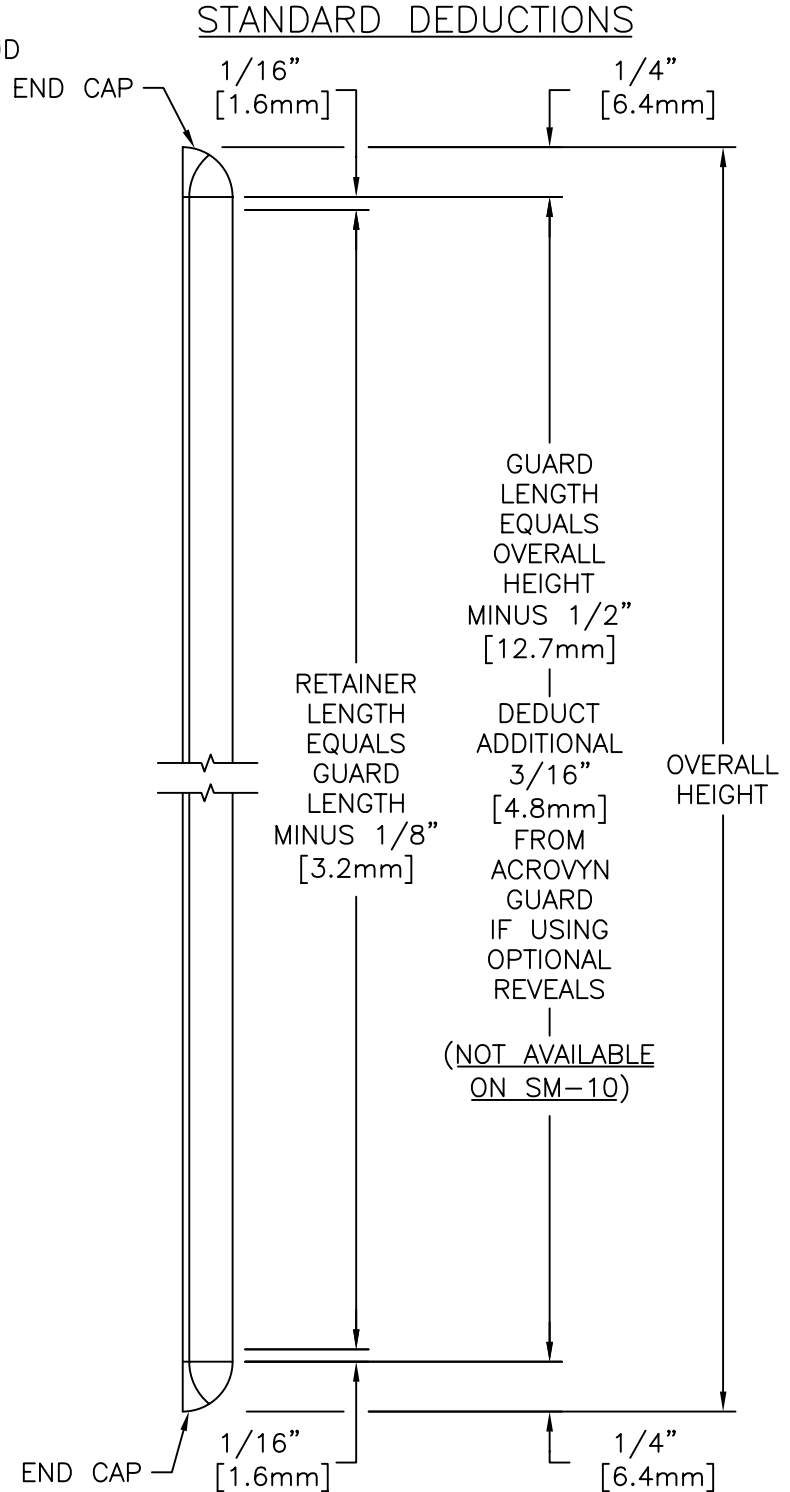

WALL CONDITION	SPECIFIED FASTENER	DRILL DIAMETERS		PART NUMBER
		WALL	RETAINER	
STEEL STUD/GYPSUM WALL WOOD STUD/GYPSUM WALL	#6 X 1-5/8" BUGLE HEAD SMS	N/A	N/A	90H079002
CONCRETE/CONC. BLOCK	{ AF-6 ALLIGATOR ANCHOR #10 X 1-1/2" PHILLIPS PAN HD. SMS }	1/4"	N/A	90H039004 90H189002
	{ AD44 ABSLF POP RIVET #8SAE FLAT WASHER STEEL PLATED }	N/A	5/32"	90H018011 90H010003

INSTALLATION INSTRUCTIONS

24QQ

SM-20M

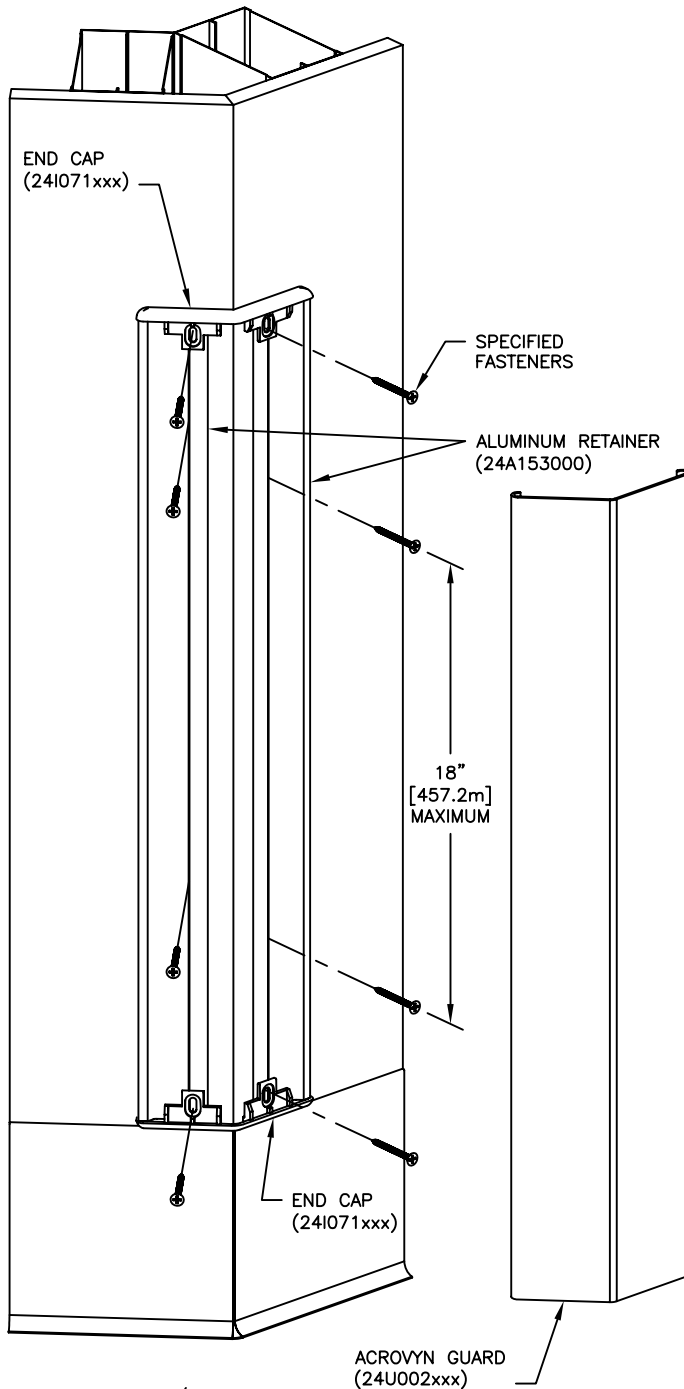

**DRYWALL/
PLASTER
APPLICATION**

1. LOCATE AND INSTALL C/S CORNER GUARDS IN ACCORDANCE WITH ARCHITECTURAL DRAWINGS AND SPECIFICATIONS. WHEN REQUIRED, C/S SHOP DRAWINGS SHOULD BE USED IN CONJUNCTION WITH THESE DOCUMENTS.
2. LAY OUT THE WORK TO BE COMPLETED, INCLUDING COMPONENT PARTS, AT EACH LOCATION TO RECEIVE CORNER GUARDS AS INDICATED BY THE C/S SHOP DRAWINGS. SPOT CHECK THE MATERIAL FOR ANY DAMAGE INCURRED DURING SHIPPING AND/OR HANDLING AT THE JOB SITE.
3. CUT THE ALUMINUM TO LENGTH USING THE REQUIRED DEDUCTIONS (REFERENCE STANDARD DEDUCTIONS).
4. INSTALL RETAINER 1/4" [6.4mm] ABOVE COVE BASE OR FINISH FLOOR USING THE REQUIRED FASTENERS AS NOTED ON REVERSE.
5. INSTALL THE BOTTOM END CAP BY ABUTTING THE CAP WITH THE END OF THE RETAINER, ALLOWING THE FLANGES TO OVERLAP THE END OF THE RETAINER AS SHOWN. SECURE INTO POSITION USING THE SPECIFIED FASTENERS.

NOTE: TO AID IN LOCATING THE END CAPS CORRECTLY, CUT A 4" [101.6mm] SECTION OF GUARD FROM SCRAP AND SNAP IT ON THE RETAINER. LOCATE THE CAP SO IT ALIGNS FLUSH WITH TOP AND BOTTOM OF THE GUARD.

NOTE: FOR MASONRY INSTALLATIONS: ATTACH THE END CAPS TO THE RETAINER FIRST, THEN ATTACH THE ASSEMBLED UNIT TO THE SUBSTRATE.

6. REPEAT THE PROCEDURE TO INSTALL THE TOP END CAP.
7. CUT THE ACROVYN GUARD TO THE PROPER LENGTH USING THE REQUIRED DEDUCTIONS (REFERENCE STANDARD DEDUCTIONS).
8. FINISH INSTALLATION BY SNAPPING THE ACROVYN GUARD ONTO THE RETAINER.

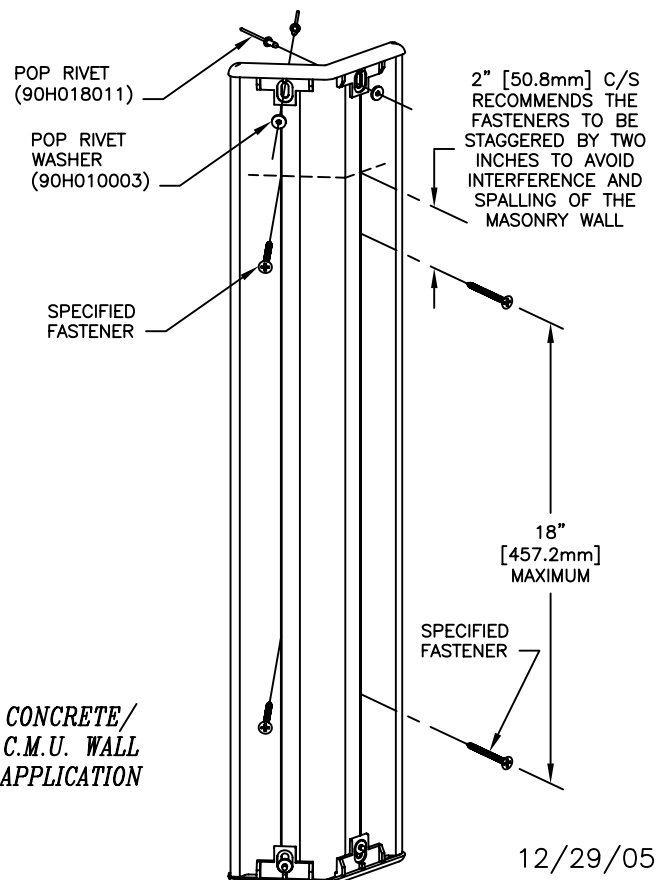

**CONCRETE/
C.M.U. WALL
APPLICATION**

12/29/05

**CONSTRUCTION SPECIALTIES INC
DECOGARD PRODUCTS**

MUNJCY, PENNSYLVANIA 17756
MISSISSAUGA, ONTARIO L5E 2C2

**A Member of the
CS GROUP
of Companies**

This document is the property of Construction Specialties, Inc. and contains CONFIDENTIAL PROPRIETARY INFORMATION that is not to be disclosed to third parties and is not to be used without approval in writing from Construction Specialties, Inc.

FOR FURTHER ASSISTANCE CALL (800) 233-8493 OR FAX (570) 546-5169 OR IN CANADA CALL (888) 895-8955 OR FAX (905) 274-6241