

**NOTES:**

1. MATERIAL MUST REACH 65°F MIN TO 75°F MAX 24 HOURS PRIOR TO INSTALLATION. THIS IS ESSENTIAL TO MINIMIZE EXPANSION AND CONTRACTION OF THE MATERIAL.
2. FOR DRYWALL/PLASTER WALL CONSTRUCTION, IT IS RECOMMENDED FOR FASTENERS TO BE ENGAGED INTO METAL/WOOD STUDS TO MAINTAIN MAXIMUM PULLOUT STRENGTH.
3. ALL DIMENSIONS ARE TYPICAL.

WALL CONDITION	SPECIFIED FASTENER	DRILL DIAMETERS		C/S PART NUMBER
		WALL	RETAINER	
STEEL STUD/GYPSUM WALL	1/4-20 X 5" RD HD BOLT WITH FLAT WASHER 1/4" TOGGLER WING	3/4"	9/32"	90H049002 90H024003 90H062004
CONCRETE/CONC. BLOCK	#14 X 5" PHILLIPS ROUND HEAD AP SCREW	3/16"	9/32"	90H287002
WOOD STUD/GYPSUM WALL	#14 X 5" PHILLIPS ROUND HEAD AP SCREW	1/8"	9/32"	90H287002

# INSTALLATION INSTRUCTIONS

24FE

## ECR-48 & ECR-48S CRASH RAIL

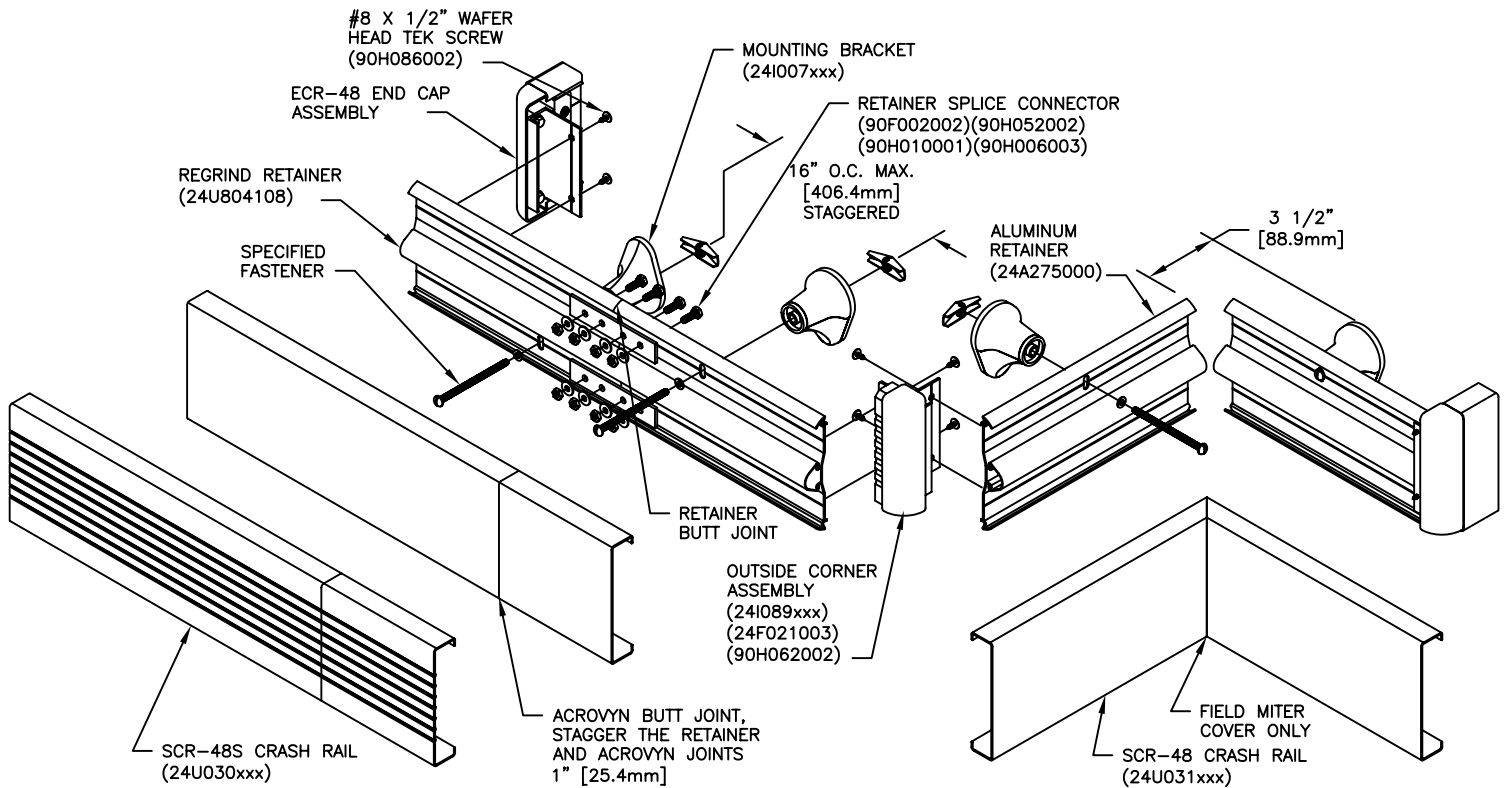

1. ESTABLISH CRASH RAIL HEIGHT ABOVE FINISH FLOOR. DEDUCT 1-13/32" [35.9mm] AND SNAP A CHALK LINE AT THAT HEIGHT. THIS MARKS THE LOCATION OF THE RETAINER FASTENERS.
2. CUT THE CONTINUOUS ALUMINUM RETAINER AND THE REGRIND RETAINER TO LENGTH, USING THE REQUIRED DEDUCTIONS AS NOTED (SEE LAYOUT VIEW). PRE-DRILL CLEARANCE HOLES IN THE ALUMINUM RETAINER 16" [406.4mm] O.C., STAGGERED AS REQUIRED (SEE "NOTE 2" AND CHART BELOW LAYOUT VIEW ON REVERSE SIDE).
3. USING THE RETAINER AS A TEMPLATE, MARK THE LOCATION OF THE FASTENERS (SEE "NOTE 2" ON REVERSE SIDE). DRILL CLEARANCE HOLES IN WALL SURFACE FOR MOUNTING HARDWARE (SEE CHART BELOW LAYOUT VIEW ON REVERSE SIDE). USE A LEVEL TO ENSURE RETAINER IS PLUMB.
4. ATTACH THE REGRIND RETAINER BY ALIGNING THE REGRIND RETAINER WITH THE ALUMINUM RETAINER AND SNAPPING IT INTO PLACE.
5. ATTACH END CAPS/OUTSIDE CORNERS BY ALIGNING THE END CAP /OUTSIDE CORNER WITH THE END OF THE ALUMINUM RETAINER AND SECURING INTO POSITION USING TWO 1/2" WAFER HEAD TEK SCREWS AT EACH END CAP AND FOUR AT EACH OUTSIDE CORNER (SEE DETAIL ABOVE).

**NOTE:** TO AID IN LOCATING THE END CAPS CORRECTLY, CUT A 4" [101.6mm] SECTION OF GUARD FROM SCRAP AND SNAP IT ON THE RETAINER. LOCATE THE CAP SO IT ALIGNS FLUSH WITH TOP AND BOTTOM OF THE GUARD.

6. INSTALL EACH SECTION OF ASSEMBLED RETAINER, IN SUCCESSION, USING THE MOUNTING BRACKETS AND THE APPROPRIATE HARDWARE. USE A LEVEL TO ENSURE RETAINER IS PLUMB.
7. CUT THE ACROVYN COVER TO THE PROPER LENGTH. THE COVER LENGTH IS DETERMINED BY MEASURING THE DISTANCE BETWEEN THE INSTALLED END CAPS AND/OR INSIDE/OUTSIDE CORNER ASSEMBLIES.

**NOTE:** IT IS RECOMMENDED THAT THE ACROVYN COVERS BE CUT SLIGHTLY LONGER (1/32" UP TO 5'-0", 1/16" OVER 5'-0") THAN THE MEASURED DISTANCE. THIS ADDITIONAL LENGTH WILL PROVIDE FOR A TIGHTER GUARD-TO-END CAP FIT.

8. ALIGN THE TOP OF THE ACROVYN COVER WITH THE TOP OF THE ALUMINUM RETAINER AND SNAP THE GUARD ONTO THE BOTTOM SECTION OF THE RETAINER.

**NOTE:** MANUFACTURER RECOMMENDS ALL PRINTED "PRODUCT IDENTIFICATION" ON THE REAR OF THE ACROVYN PROFILE SHALL BE ORIENTED IN THE SAME DIRECTION DURING INSTALLATION TO ENSURE PROPER ALIGNMENT AT SPLICE BUTT JOINTS.

2/1/07

CONSTRUCTION SPECIALTIES INC  
DECOGARD PRODUCTS

A Member of the  
**CS GROUP**  
of Companies

This document is the property of Construction Specialties, Inc. and contains CONFIDENTIAL PROPRIETARY INFORMATION that is not to be disclosed to third parties and is not to be used without approval in writing from Construction Specialties, Inc.

MUNCY, PENNSYLVANIA 17756  
MISSISSAUGA, ONTARIO L5E 2C2

FOR FURTHER ASSISTANCE CALL (800) 233-8493 OR FAX (570) 546-5169 OR IN CANADA CALL (888) 895-8955 OR FAX (905) 274-6241