

C/S GROUP *Model:* BCR-95 CRASHRAIL

24HHB

NOTE: MATERIAL MUST REACH 65°F MIN TO 75°F MAX 24 HOURS PRIOR TO INSTALLATION. THIS IS ESSENTIAL TO MINIMIZE EXPANSION AND CONTRACTION OF THE MATERIAL.

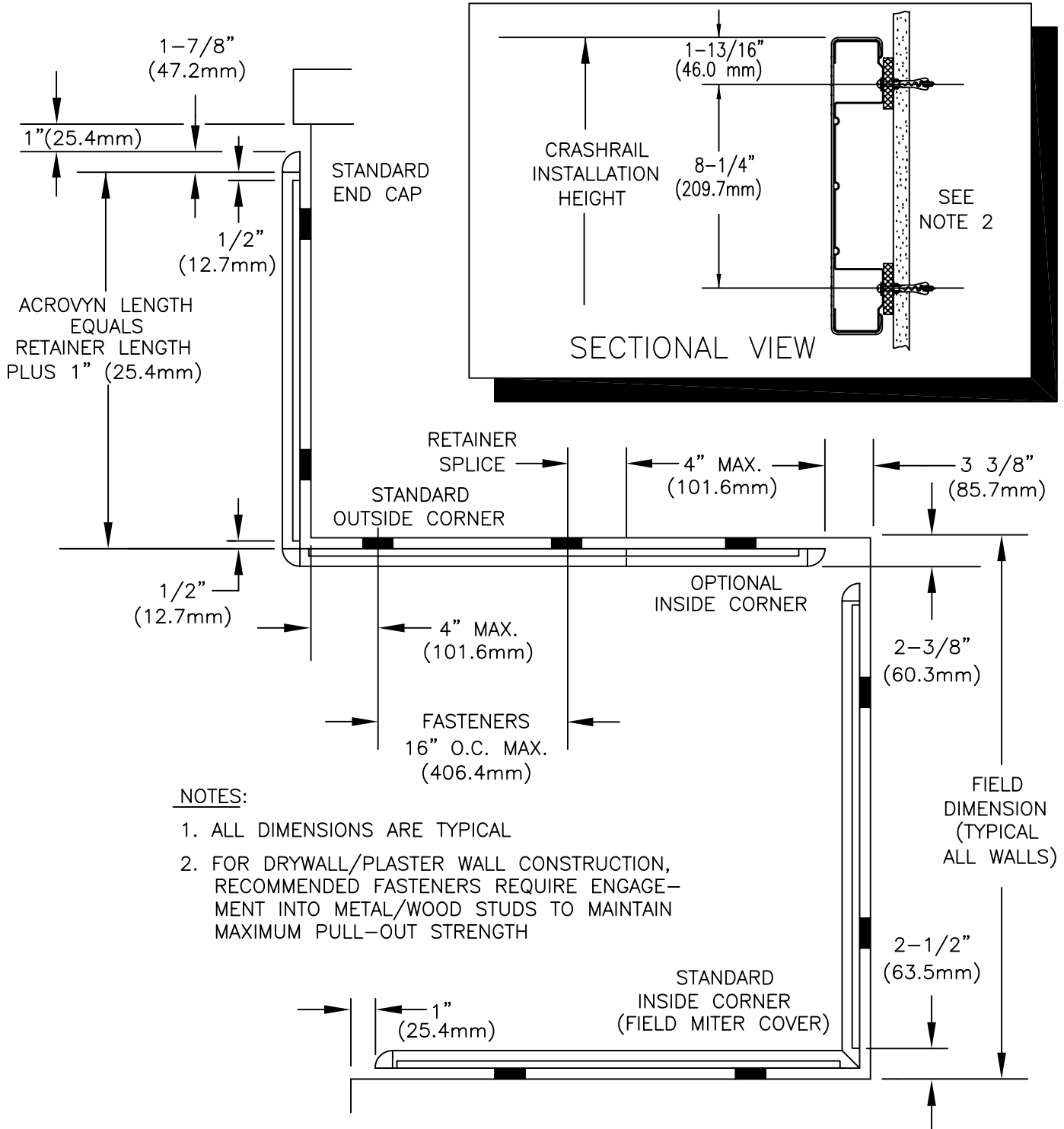

WALL CONDITION	SPECIFIED FASTENER	DRILL DIAMETERS		C/S PART NUMBER
		WALL	RETAINER	
STEEL STUD/GYPSUM WALL	AF-6 ALLIGATOR ANCHOR #10 X 2" PHILLIPS PAN HD. SMS	15/64"	9/32"	90H039004 90H191002
CONCRETE/CONC. BLOCK	AF-6 ALLIGATOR ANCHOR #10 X 2" PHILLIPS PAN HD. SMS	1/4"	9/32"	90H039004 90H191002
WOOD STUD/GYPSUM WALL	#9 X 2 1/4" WAFER HD PH DRYWALL SCREW	N/A	N/A	90H421002

INSTALLATION INSTRUCTIONS

BCR-95

24HHB

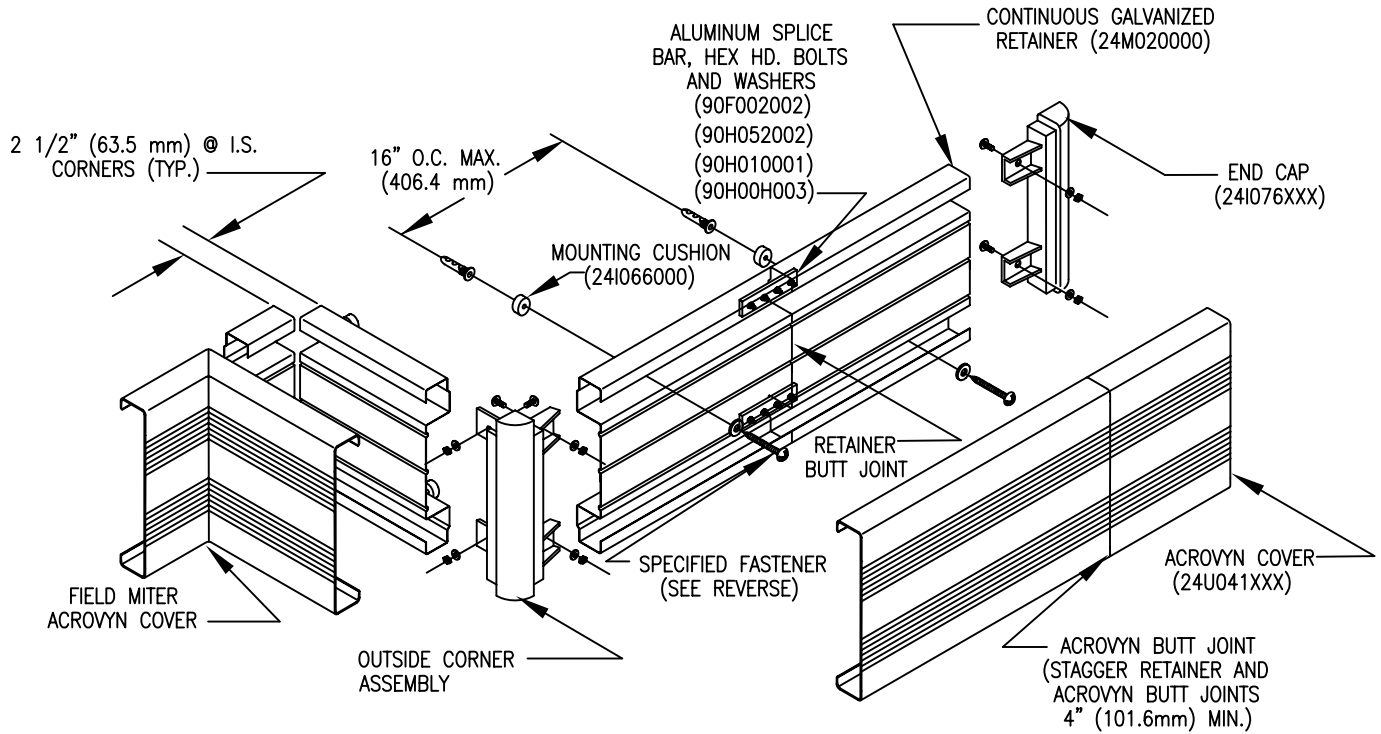

1. ESTABLISH CRASHRAIL HEIGHT ABOVE FINISH FLOOR. DEDUCT 1-13/16"(46.0mm) AND SNAP A CHALK LINE AT THAT HEIGHT. PROVIDE A SECOND CHALK LINE 8-1/4"(209.7mm) BELOW FIRST LINE. THIS MARKS THE LOCATION OF THE BUMPER CUSHION AND RETAINER FASTENERS.
2. CUT THE CONTINUOUS GALVANIZED RETAINER TO LENGTH USING THE REQUIRED DEDUCTIONS AS NOTED (SEE REVERSE). PRE-DRILL CLEARANCE HOLES IN THE GALVANIZED RETAINER AS REQUIRED.
3. USE THE RETAINER AS A TEMPLATE AND DRILL CLEARANCE HOLES IN WALL SURFACE FOR MOUNTING HARDWARE. SEE "NOTE 2" REVERSE SIDE.
4. ATTACH END CAPS/OUTSIDE CORNERS BY ALIGNING THE END CAP/OUTSIDE CORNER WITH THE END OF THE GALV. RETAINER AND SECURING INTO POSITION USING TWO (2) 1/4 X 20 X 1/2" BOLTS AT EACH END CAP AND FOUR (4) AT EACH OUTSIDE CORNER (TWO (2) @ EA. LEG).
5. ATTACH THE RETAINER TO THE WALL SURFACE USING THE BUMPER CUSHIONS AND THE APPROPRIATE HARDWARE. USE A LEVEL TO ENSURE RETAINER IS PLUMB.
6. CUT THE ACROVYN COVER TO THE PROPER LENGTH. ALIGN THE TOP OF THE ACROVYN COVER WITH THE TOP OF THE ALUM. RETAINER AND SNAP THE GUARD ONTO THE BOTTOM SECTION OF THE RETAINER.
NOTE: MANUFACTURER RECOMMENDS ALL PRINTED "PRODUCT IDENTIFICATION" ON THE REAR OF THE ACROVYN PROFILE SHALL BE ORIENTED IN THE SAME DIRECTION DURING INSTALLATION TO ENSURE PROPER ALIGNMENT AT SPLICE BUTT JOINTS.

7/7/05

CONSTRUCTION SPECIALTIES, INC.
AND/OR
DecoGard Products, Inc.

MUNCY, PENNSYLVANIA 17756-9106
VISTA, CALIFORNIA 92083-9438
MISSISSAUGA, ONTARIO L5E 2C2

A member of the
CS GROUP
of companies

FOR FURTHER ASSISTANCE CALL 1-888-834-4455 OR FAX 570-546-5169
OR IN CANADA CALL 905-274-3611 OR FAX 905-274-6241

This document is the property of Construction Specialties, Inc. and contains CONFIDENTIAL PROPRIETARY INFORMATION that is not to be disclosed to third parties and is not to be used without approval in writing from Construction Specialties, Inc.