

**NOTES:**

1. MATERIAL MUST REACH 65°F MIN TO 75°F MAX 24 HOURS PRIOR TO INSTALLATION. THIS IS ESSENTIAL TO MINIMIZE EXPANSION AND CONTRACTION OF THE MATERIAL.
2. FOR DRYWALL/PLASTER WALL CONSTRUCTION, IT IS RECOMMENDED FOR FASTENERS TO BE ENGAGED INTO METAL/WOOD STUDS TO MAINTAIN MAXIMUM PULLOUT STRENGTH.
3. ALL DIMENSIONS ARE TYPICAL.
4. AF-6 ALLIGATOR ANCHORS SHOULD SEAT FLUSH WITH GYPSUM WALL.

WALL CONDITION	SPECIFIED FASTENER	DRILL DIAMETERS		C/S PART NUMBER
		WALL	RETAINER	
STEEL STUD/GYPSUM WALL	AF-6 Alligator Anchors #10 x 2" PHILLIPS PAN HEAD SMS 1/4" FLAT WASHER STEEL PLATES SAE	1/4"	1/4"	90H191002 90H007003 90H039004 90H191002
CONCRETE/CONC. BLOCK	AF-6 ALLIGATOR ANCHORS #10 x 2" PHILLIPS PAN HEAD SMS 1/4" FLAT WASHER STEEL PLATES SAE	1/4"	1/4"	90H007003 90H039004
WOOD STUD/GYPSUM WALL	#9 x 2 1/4" WAFER HD PH DRYWALL SCREW	N/A	N/A	90H421002

# INSTALLATION INSTRUCTIONS

24AY

## BCR-80 CRASH RAIL

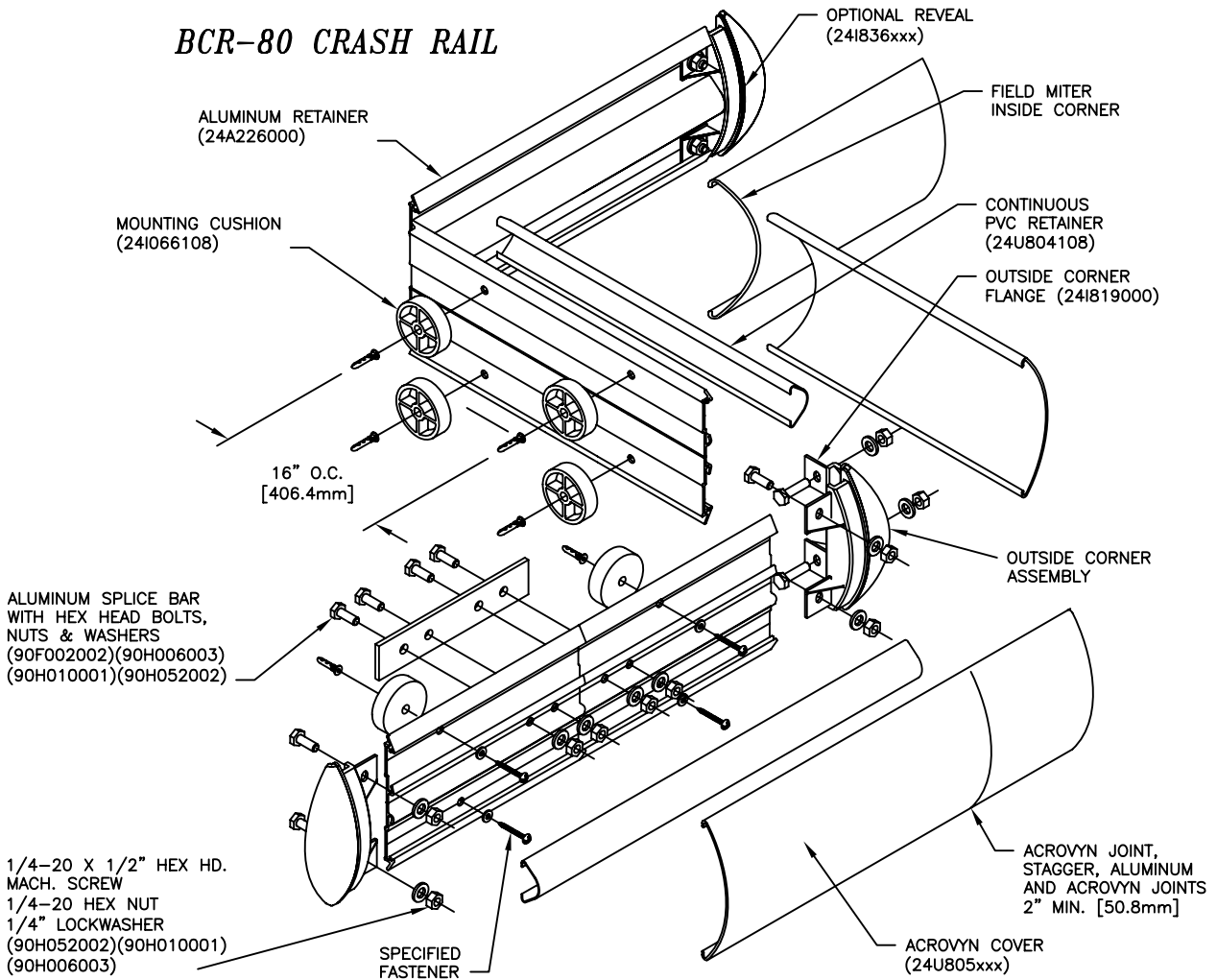

1. ESTABLISH CRASH RAIL HEIGHT ABOVE FINISH FLOOR. DEDUCT 1 5/8" [41.3mm] AND SNAP A CHALK LINE AT THAT HEIGHT. THIS MARKS THE LOCATION OF THE TOP FASTENERS FOR THE ALUMINUM RETAINER.
2. CUT THE CONTINUOUS ALUMINUM RETAINER TO LENGTH NOTING THE REQUIRED DEDUCTIONS ON REVERSE. PRE-DRILL 5/16" [7.9mm] CLEARANCE HOLES FOR THE FASTENERS 3" [76.2mm] FROM EACH END AND 16" [406.4mm] O.C. MAX. ALONG THE RETAINER LENGTH.
3. USING THE RETAINER AS A TEMPLATE, DRILL 1/4" [6.3mm] CLEARANCE HOLES IN WALL SURFACE FOR MOUNTING HARDWARE. SEE "NOTE 2" ON REVERSE SIDE.
4. ATTACH END CAPS/OUTSIDE CORNERS BY SLIDING THE END CAP/OUTSIDE CORNER ONTO THE END OF THE ALUMINUM RETAINER AND SECURING INTO POSITION USING TWO (2) 1/4-20 X 1/2" HEX HEAD MACHINE SCREW WITH WASHER AND 1/4-20 NUT AT EACH END CAP AND FOUR (4) AT EACH OUTSIDE CORNER.
5. END CAPS MUST BE INSTALLED PLUMB TO ENSURE BEST POSSIBLE FIT BETWEEN THE CAP AND THE GUARD. TO AID IN LOCATING THE END CAPS CORRECTLY, CUT A 4" [101.6mm] SECTION OF GUARD FROM SCRAP AND SNAP IT ON THE RETAINER. LOCATE THE CAP SO IT IS ALIGNED FLUSH WITH TOP AND BOTTOM OF THE GUARD.
6. INSTALL EACH SECTION OF ASSEMBLED RETAINER ONTO THE WALL, IN SUCCESSION, USING THE APPROPRIATE FASTENERS. USE A LEVEL TO ENSURE RETAINER IS LEVEL.
7. CUT THE CONTINUOUS PVC RETAINER TO LENGTH NOTING THE REQUIRED DEDUCTIONS (SEE REVERSE) AND INSTALL ONTO ALUMINUM RETAINER.
8. CUT THE ACROVYN COVER TO LENGTH. THE COVER LENGTH IS DETERMINED BY MEASURING THE DISTANCE BETWEEN THE INSTALLED END CAPS AND/OR INSIDE/OUTSIDE CORNER ASSEMBLIES. **NOTE:** IT IS RECOMMENDED THAT THE ACROVYN COVERS BE CUT SLIGHTLY LONGER (1/32" UP TO 5'-0", 1/16" OVER 5'-0") THAN THE MEASURED DISTANCE. THIS ADDITIONAL LENGTH WILL PROVIDE FOR A TIGHTER GUARD-TO-END CAP FIT. ALIGN THE TOP OF THE ACROVYN COVER WITH THE TOP OF THE ALUMINUM RETAINER AND SNAP THE GUARD ONTO THE RETAINER.

**NOTE:** MANUFACTURER RECOMMENDS ALL PRINTED "PRODUCT IDENTIFICATION" ON THE REAR OF THE ACROVYN PROFILE SHALL BE ORIENTED IN THE SAME DIRECTION DURING INSTALLATION TO ENSURE PROPER ALIGNMENT AT SPLICE BUTT JOINTS.

CONSTRUCTION SPECIALTIES INC  
DECOGARD PRODUCTS

MUNCY, PENNSYLVANIA 17756  
MISSISSAUGA ONTARIO L5E 2C2

A Member of the  
**CS GROUP**  
of Companies

This document is the property of Construction Specialties, Inc. and contains CONFIDENTIAL PROPRIETARY INFORMATION that is not to be disclosed to third parties and is not to be used without approval in writing from Construction Specialties, Inc.

11/22/06

FOR FURTHER ASSISTANCE CALL (800) 233-8493 OR FAX (570) 546-5169 OR IN CANADA CALL (888) 895-8955 OR FAX (905) 274-6241