

**SMWS SERIES CORNER GUARD**

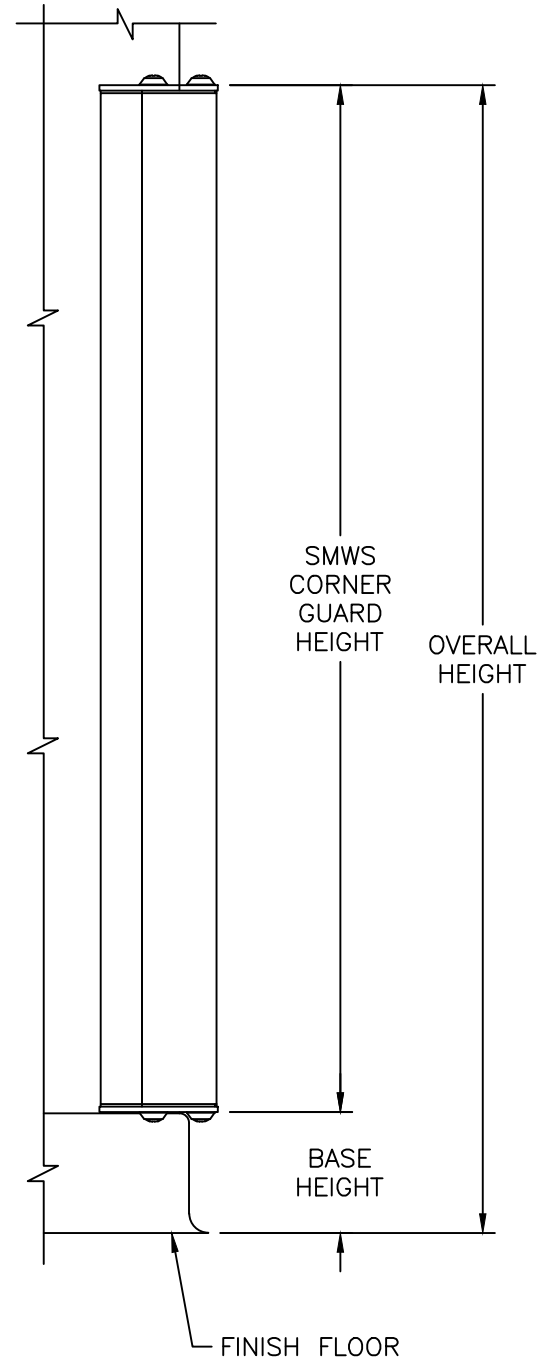

**NOTE:** MATERIAL MUST REACH 65°F MIN TO 75°F MAX 24 HOURS PRIOR TO INSTALLATION. THIS IS ESSENTIAL TO MINIMIZE EXPANSION AND CONTRACTION OF THE MATERIAL.

**SMWS SERIES CORNER GUARD**

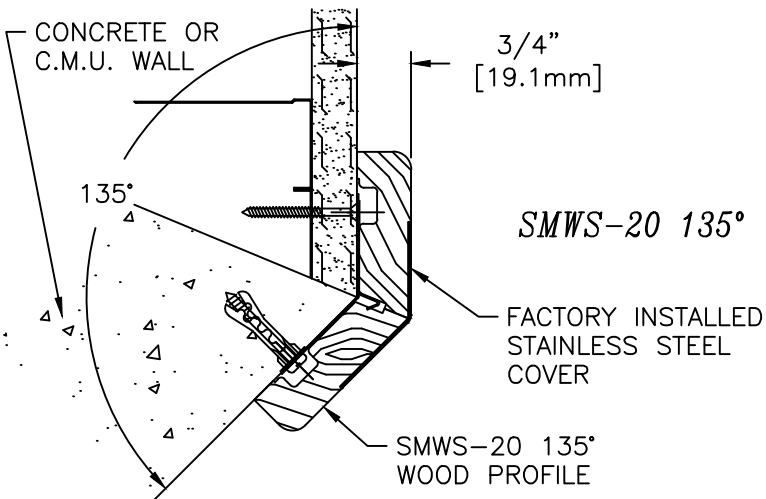
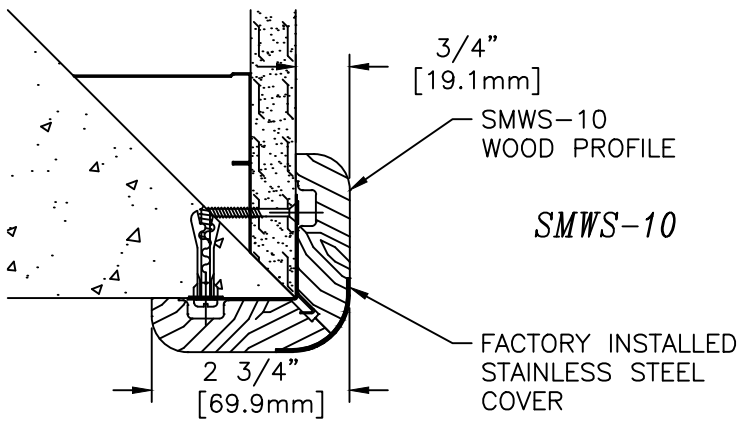
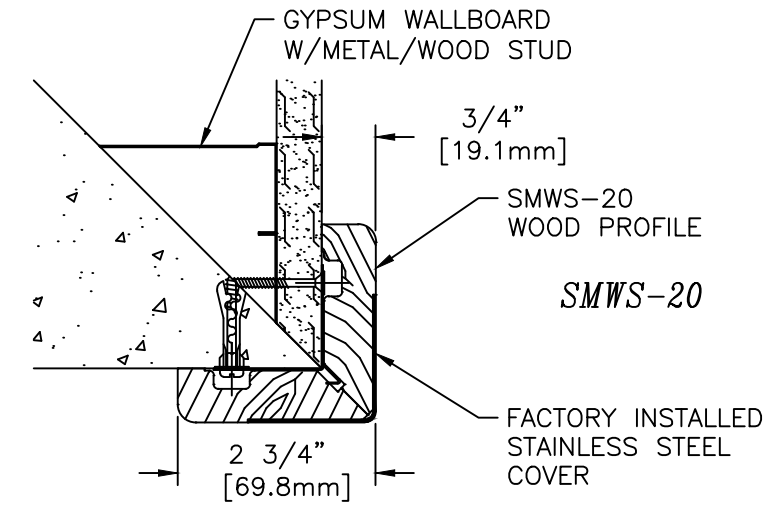

SMWS-20 135°  
WOOD PROFILE  
(24W331xxx)



SMWS-20 135°  
STAINLESS STEEL COVER  
(24F125004)

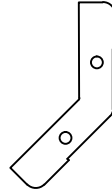

SMWS-20 135°  
ACCENT REVEAL  
(24I106108)

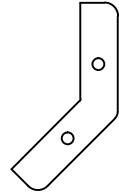

SMWS-20 135° END CAP  
STAINLESS STEEL (24S087000)  
WOOD (24W361xxx)

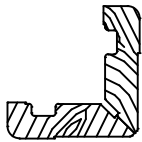

SMWS-20  
WOOD PROFILE  
(24W331xxx)



SMWS-20  
STAINLESS STEEL COVER  
(24F110004)

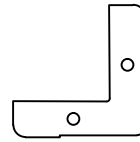

SMWS-20  
ACCENT REVEAL  
(24I105108)

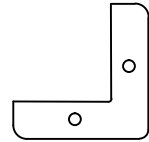

SMWS-20 END CAP  
STAINLESS STEEL (24S085000)  
WOOD (24W340xxx)



SMWS-10  
WOOD PROFILE  
(24W330xxx)



SMWS-10  
STAINLESS STEEL COVER  
(24F090004)

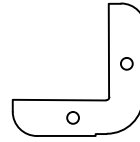

SMWS-10  
ACCENT REVEAL  
(24I103108)

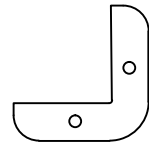

SMWS-10 END CAP  
STAINLESS STEEL (24S084000)  
WOOD (24W339xxx)

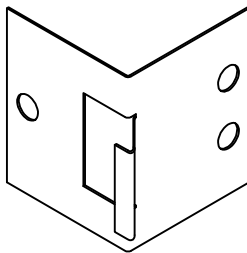

STAINLESS STEEL  
CORNER MOUNT CLIP  
(24M043000)



FASTENER #1  
#10 x 3/4"  
OVAL HD S/S PH SMS  
(90H459002)



FASTENER #2  
#10 COUNTERSUNK FLANGED  
S/S WASHER (90H047003)

WALL CONDITION	SPECIFIED FASTENER	DRILL DIAMETERS		PART NUMBER
		WALL	RETAINER	
STEEL STUD/GYPSUM WALL WOOD STUD/GYPSUM WALL	#6 X 1-5/8" BUGLE HD. TEK DRYWALL SCREW	N/A	N/A	90H079002
CONCRETE/CONC. BLOCK	{ AF-6 PLASTIC ANCHOR { #10 X 1-1/2" PHILLIPS PAN HD. SMS }	1/4"	N/A	90H039004 90H189002

**SMWS SERIES CORNER GUARD**

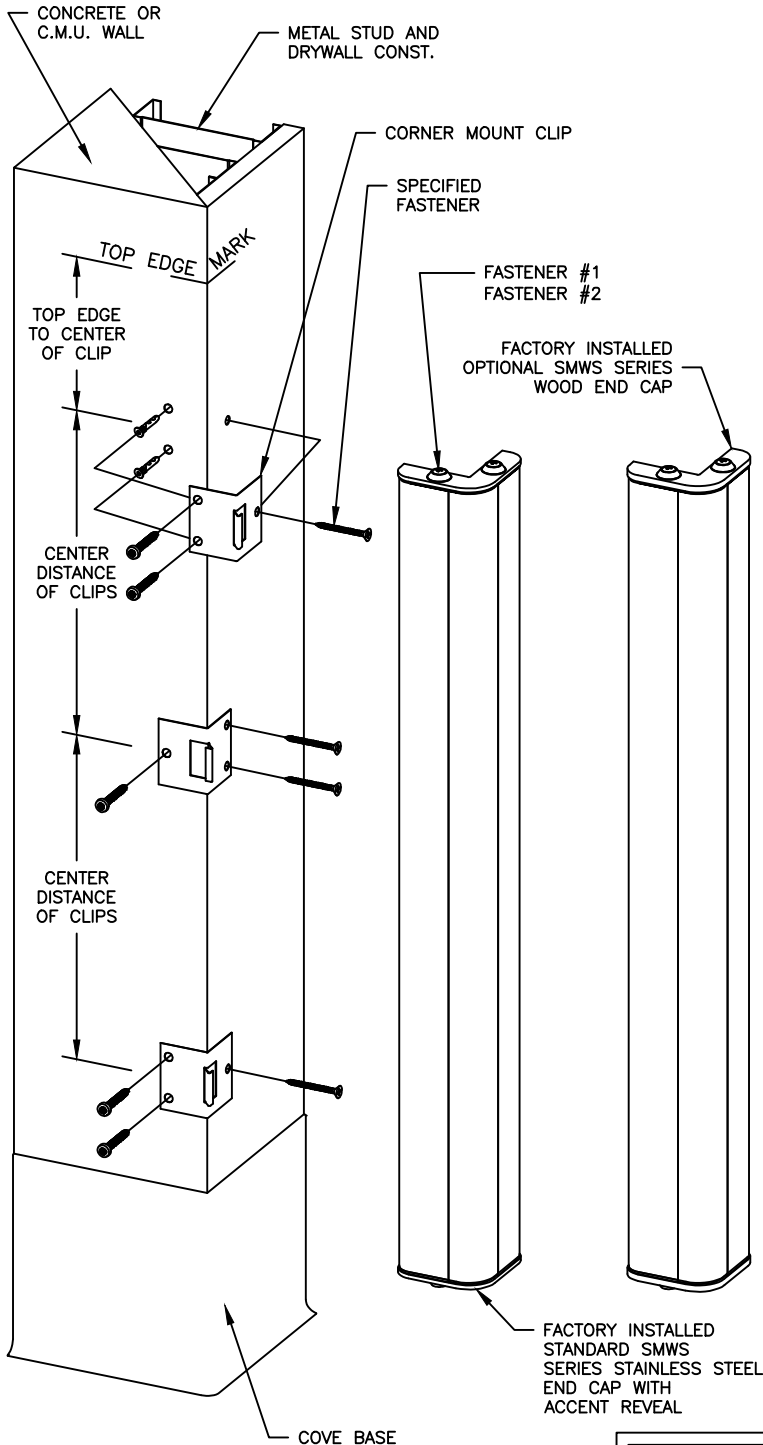

1. DETERMINE DESIRED HEIGHT OF CORNER GUARD AND PENCIL MARK WALL TO INDICATE TOP EDGE OF CORNER GUARD.

2. TO DETERMINE LOCATION OF CORNER MOUNT CLIPS ON WALL, MEASURE SLOT SPACING ON BACKSIDE OF CORNER GUARD. MEASURE TOP EDGE-TO-CENTER AND CENTER-TO-CENTER DISTANCES OF EXISTING SLOTS AND TRANSFER TO WALL.

3. CENTER CORNER MOUNT CLIPS ON TRANSFERRED MEASUREMENTS.

4. DRILL CLEARANCE HOLES IN WALL SURFACE FOR MOUNTING HARDWARE, USING CORNER MOUNT CLIPS AS A TEMPLATE.

**WARNING:** CORNER MOUNT CLIPS MUST BE STAGGERED/REVERSED AND SEATED TIGHT AGAINST WALL.

5. INSTALL EACH CORNER MOUNT CLIP, IN SUCCESSION, USING THE SPECIFIED FASTENERS.

**WARNING:** BE SURE CORNER MOUNT CLIPS ARE TIGHT AGAINST WALL AND IN CORRECT LOCATION. ONCE CORNER GUARD IS INSTALLED, IT WILL BE DIFFICULT TO REMOVE WITHOUT DAMAGING CORNER GUARD, WALL AND/OR CORNER MOUNT CLIPS.

6. POSITION CORNER GUARD IN ITS PROPER LOCATION AND BEGIN TO SEAT THE INDIVIDUAL CORNER MOUNT CLIPS BY CAREFULLY PUSHING/TAPPING ON THE CORNER GUARD.

DUE TO THE NATURE OF WOOD, COMPONENT COLORS MAY VARY. SORT WOOD COMPONENTS AND MATCH PARTS BY COLOR.

10/20/11