

SCR-64 CRASH RAIL

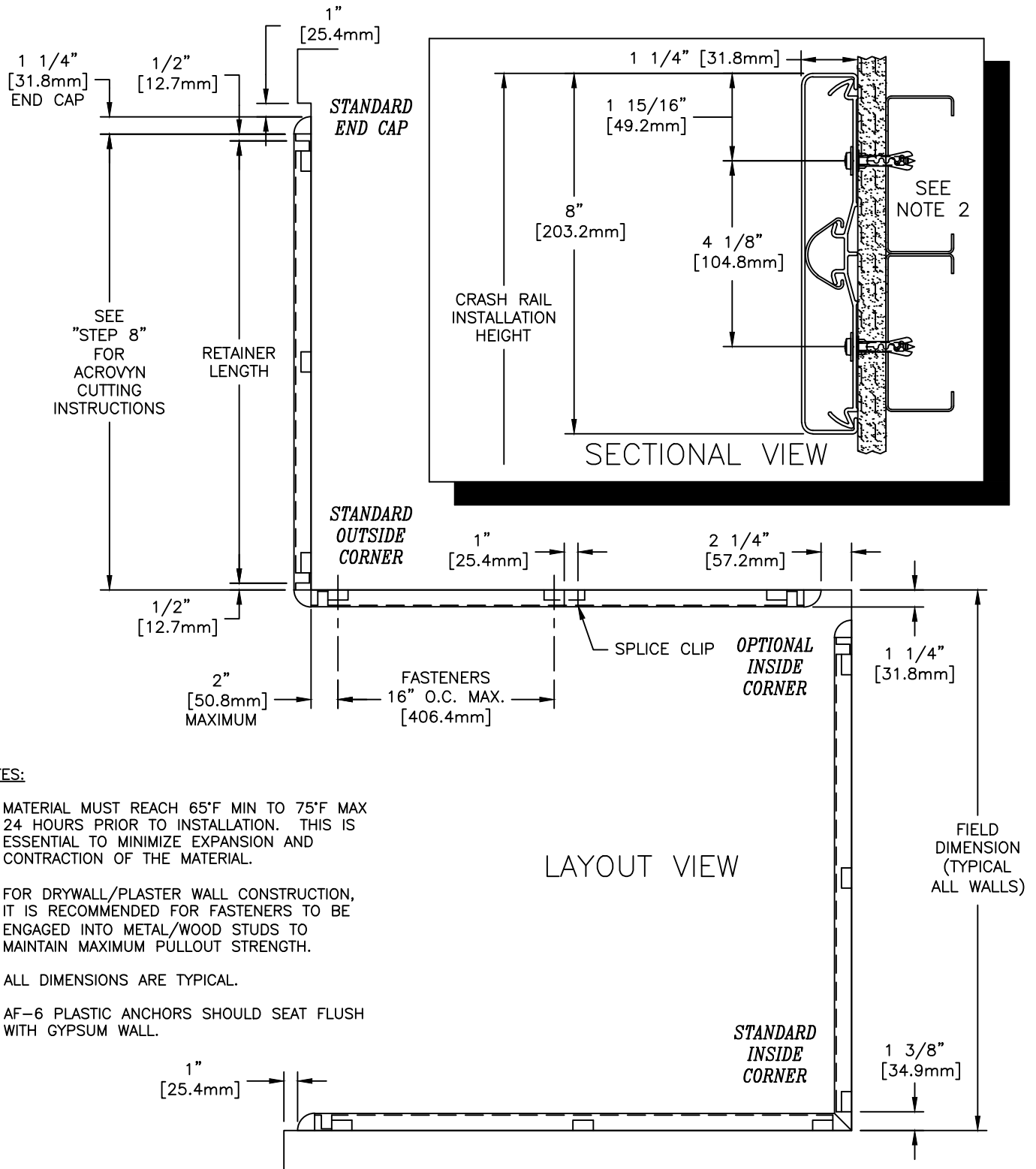

NOTES:

1. MATERIAL MUST REACH 65°F MIN TO 75°F MAX 24 HOURS PRIOR TO INSTALLATION. THIS IS ESSENTIAL TO MINIMIZE EXPANSION AND CONTRACTION OF THE MATERIAL.
2. FOR DRYWALL/PLASTER WALL CONSTRUCTION, IT IS RECOMMENDED FOR FASTENERS TO BE ENGAGED INTO METAL/WOOD STUDS TO MAINTAIN MAXIMUM PULLOUT STRENGTH.
3. ALL DIMENSIONS ARE TYPICAL.
4. AF-6 PLASTIC ANCHORS SHOULD SEAT FLUSH WITH GYPSUM WALL.

SCR-64 CRASH RAIL



ACROVYN CRASH
RAIL COVER
(24U042xxx)

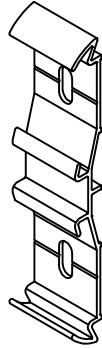

ACROVYN CRASH
RAIL RETAINER
1-1/2" CLIP
(24F106001)

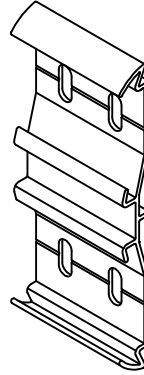

ACROVYN CRASH
RAIL RETAINER
3-3/16" CLIP
(24F107002)



CONTINUOUS VINYL
BUMPER
(24U804108)

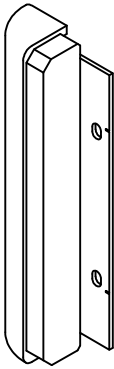

CRASH RAIL END CAP
(24I078xxx)

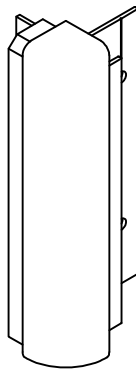

CRASH RAIL OUTSIDE
CORNER ASSEMBLY



ACROVYN SPLICE COVER
(24F227108)

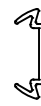

ACROVYN SPLICE
COVER RETAINER
(24F228000)

WALL CONDITION	SPECIFIED FASTENER	DRILL DIAMETERS		C/S PART NUMBER
		WALL	RETAINER	
CONCRETE/CONCRETE BLOCK	#10 X 1 1/2" PHILLIPS PAN HEAD SMS 1/4" FLAT WASHER SAE AF-6 PLASTIC ANCHORS	1/4"	N/A	90H189002 90H007003 90H039004
STEEL STUD/GYPSUM WALL	#10 X 1 1/2" PHILLIPS PAN HEAD SMS 1/4" FLAT WASHER SAE AF-6 PLASTIC ANCHORS	1/4"	N/A	90H189002 90H007003 90H039004
WOOD STUD/GYPSUM WALL	#9 X 2 1/4" WAFER HD PH DRYWALL SCREW 1/4" FLAT WASHER SAE	N/A	N/A	90H421002 90H007003

SCR-64 CRASH RAIL

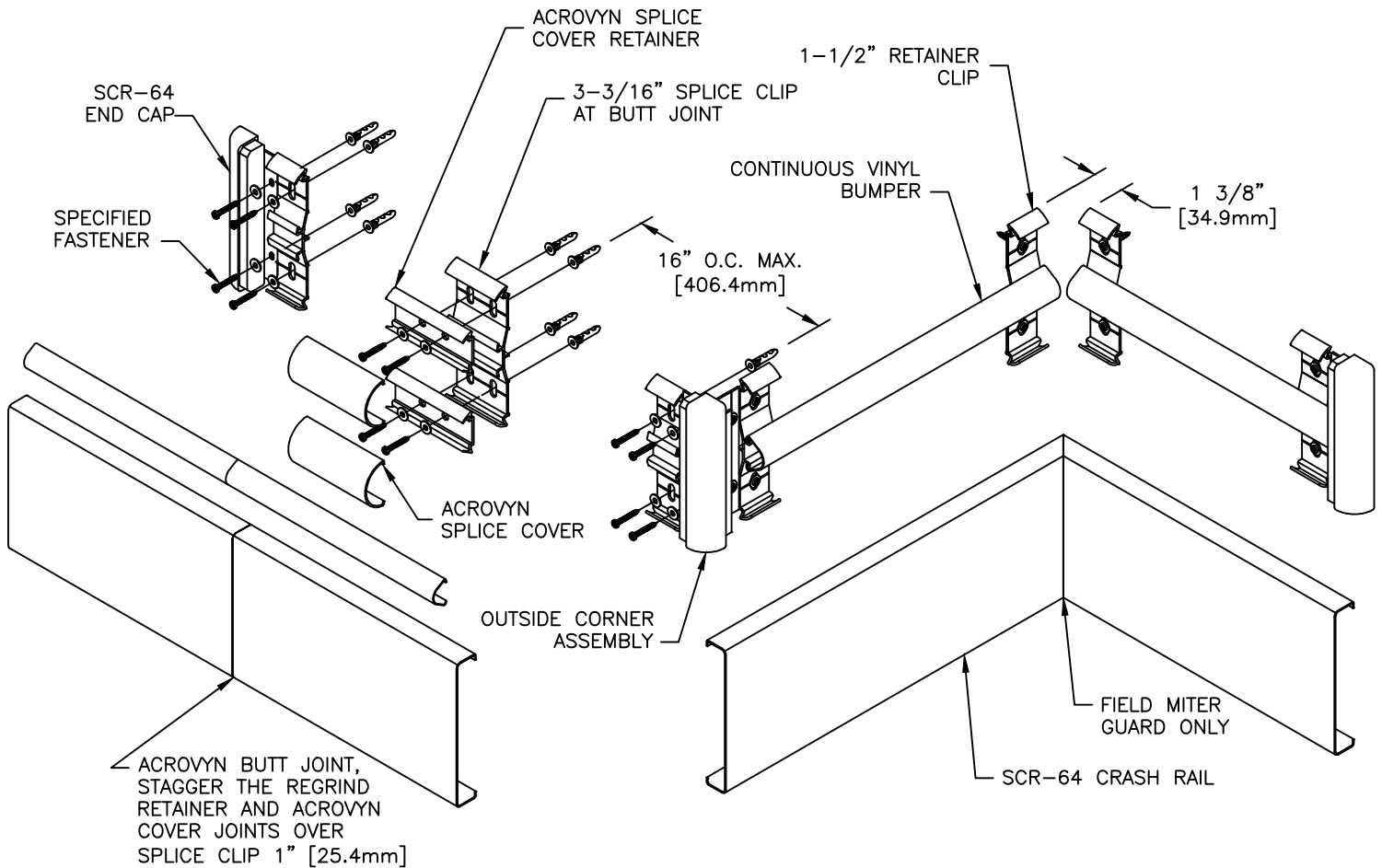

FIGURE 1.

1. ESTABLISH CRASH RAIL HEIGHT ABOVE FINISH FLOOR. DEDUCT 1-15/16" [49.2mm] AND SNAP A CHALK LINE AT THAT HEIGHT. THIS MARKS THE LOCATION OF THE TOP FASTENERS ON THE RETAINER CLIPS.
2. DETERMINE AND MARK THE LOCATION OF THE CLIPS BY USING THE REQUIRED DEDUCTIONS (SEE LAYOUT VIEW). ALIGN THE CENTER OF THE TOP MOUNTING CLIP HOLES WITH THE CHALK LINE ESTABLISHED IN "STEP 1". USING THE CLIPS AS A TEMPLATE, MARK THE LOCATION OF THE TOP AND BOTTOM FASTENERS. DRILL CLEARANCE HOLES FOR THE MOUNTING HARDWARE. REFERENCE CHART ON PAGE 2 FOR DRILL DIAMETERS.
3. DRILL TWO 9/32" PILOT HOLES THROUGH THE ACROVYN SPLICE COVER RETAINER, 1-5/32" [29.4mm] FROM THE END AND 1-11/16" [42.9mm] O.C. ALONG THE DIE MARK (SEE FIGURE 2). THE 3-3/16" CRASH RAIL RETAINER CLIP MAY ALSO BE USED AS A TEMPLATE.
4. FASTEN CLIPS TO WALL USING C/S SUPPLIED FASTENERS FOLLOWING MANUFACTURER'S GUIDELINES. 1-1/2" [38.1mm] CLIPS ARE TO BE INSTALLED AT 16" [406.4mm] O.C. AND 3-3/16" [81.0mm] CLIPS ARE TO BE INSTALLED AT BUTT JOINTS WITH THE ACROVYN SPLICE COVER RETAINER ATTACHED TO THE FACE. USE A LEVEL TO INSURE THAT THE CLIPS AND SPLICES ARE INSTALLED PLUMB. (SEE FIGURE 1)
5. ATTACH THE CONTINUOUS VINYL BUMPER BY ALIGNING IT WITH THE RETAINER CLIPS AND SNAPPING IT INTO PLACE.
6. ATTACH THE ACROVYN SPLICE COVERS TO THE APPROPRIATE RETAINERS BY ALIGNING THEM WITH THE TOP OF THE RETAINERS AND SNAPPING THEM ONTO THE BOTTOM SECTION OF THE RETAINER. (SEE FIGURE 3)
7. INSTALL ALL END CAPS/OUTSIDE CORNERS AS PER STANDARD DEDUCTIONS (SEE LAYOUT VIEW), BY BUTTING THE END CAP/OUTSIDE CORNER AGAINST THE 1-1/2" [38.1mm] RETAINER CLIP. SECURE INTO POSITION USING THE APPROPRIATE FASTENERS (SEE CHART ON PAGE 2).

NOTE: TO AID IN LOCATING THE END CAPS CORRECTLY, CUT A 4" [101.6mm] SECTION OF GUARD FROM SCRAP AND SNAP IT ON THE CLIPS. LOCATE THE CAP SO IT ALIGNS FLUSH WITH TOP AND BOTTOM OF THE GUARD.

SCR-64 CRASH RAIL

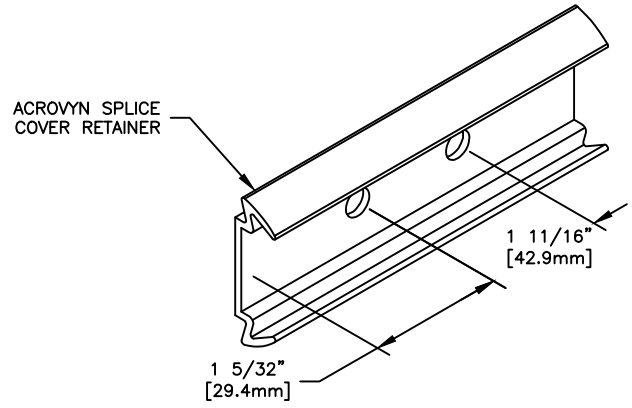

FIGURE 2.

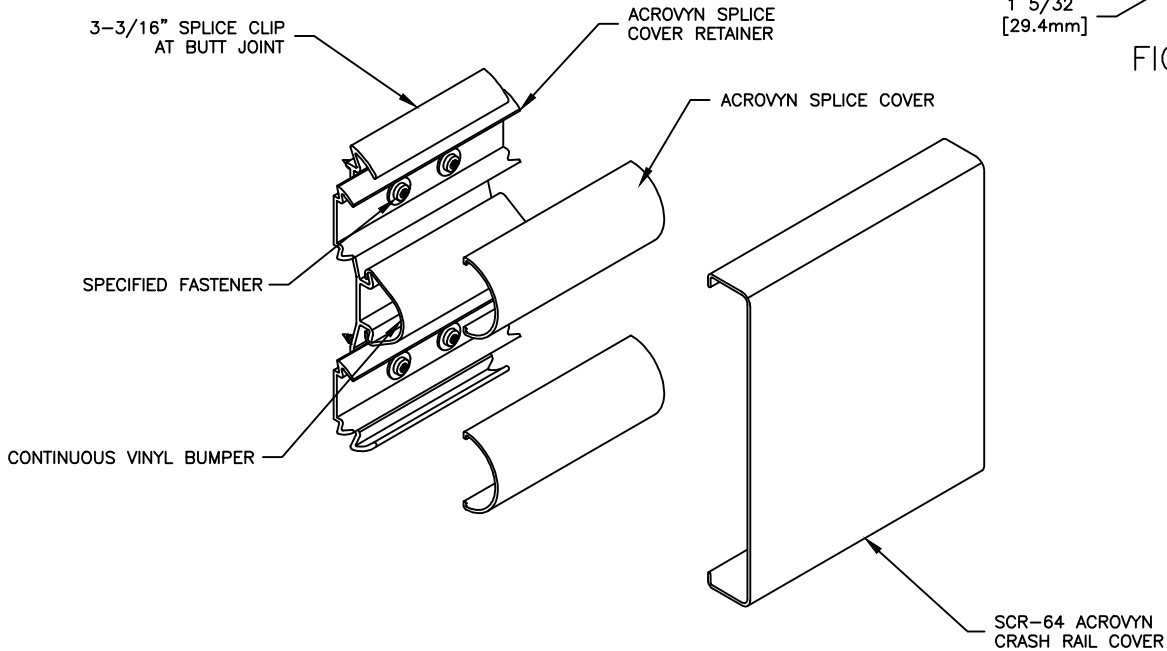

FIGURE 3.

8. CUT THE ACROVYN COVER TO THE PROPER LENGTH. THE COVER LENGTH IS DETERMINED BY MEASURING THE DISTANCE BETWEEN THE INSTALLED END CAPS AND/OR INSIDE/OUTSIDE CORNER ASSEMBLIES.

NOTE: IT IS RECOMMENDED THAT THE ACROVYN COVERS BE CUT WITH A 100 TOOTH CARBIDE TIPPED SAW BLADE OR EQUIVALENT.

NOTE: IT IS RECOMMENDED THAT THE ACROVYN COVERS BE CUT SLIGHTLY LONGER (1/32" UP TO 5'-0", 1/16" OVER 5'-0") THAN THE MEASURED DISTANCE. THIS ADDITIONAL LENGTH WILL PROVIDE FOR A TIGHTER GUARD-TO-END CAP FIT.

9. ALIGN THE TOP OF THE ACROVYN COVER WITH THE TOP OF THE RETAINER CLIPS AND SNAP THE GUARD ONTO THE BOTTOM SECTION OF THE RETAINER CLIPS.

NOTE: MANUFACTURER RECOMMENDS ALL PRINTED "PRODUCT IDENTIFICATION" ON THE REAR OF THE ACROVYN PROFILE SHALL BE ORIENTED IN THE SAME DIRECTION DURING INSTALLATION TO ENSURE PROPER ALIGNMENT AT SPLICE BUTT JOINTS.

10/19/11