

SCR-48MN CRASH RAIL

PLEASE READ

PLEASE READ THESE INSTRUCTIONS THOROUGHLY PRIOR TO BEGINNING THE SCR-48MN CRASH RAIL INSTALLATION!

THIS INSTRUCTION SHEET IS INTENDED TO PROVIDE A SPECIFIC GUIDE TO FOLLOW FOR THE INSTALLATION OF SCR-48MN CRASH RAIL. CONTAINED WITHIN IS THE TECHNICAL INFORMATION AND INSTALLATION TECHNIQUES REQUIRED TO COMPLETE AN EFFICIENT, NEAT AND LONG-LASTING INSTALLATION.

SCR-48MN CRASH RAIL MUST BE INSTALLED IN ACCORDANCE WITH THESE INSTRUCTIONS! FAILURE TO FOLLOW THESE INSTRUCTIONS MAY VOID ANY PRODUCT WARRANTIES AND RESULT IN AN UNSUCCESSFUL INSTALLATION. FOR SPECIFIC QUESTIONS REGARDING THE INSTALLATION OF SCR-48MN CRASH RAIL PLEASE CALL THE FACTORY AT (800) 233-8493 OR IN CANADA (888) 895-8955.

INSPECT ALL MATERIALS FOR DAMAGE OR MISSING PARTS. IF YOU DISCOVER DAMAGED OR MISSING MATERIALS, IN THE USA PLEASE NOTIFY THE FACTORY AT (800) 233-8493, AND IN CANADA (888) 895-8955.

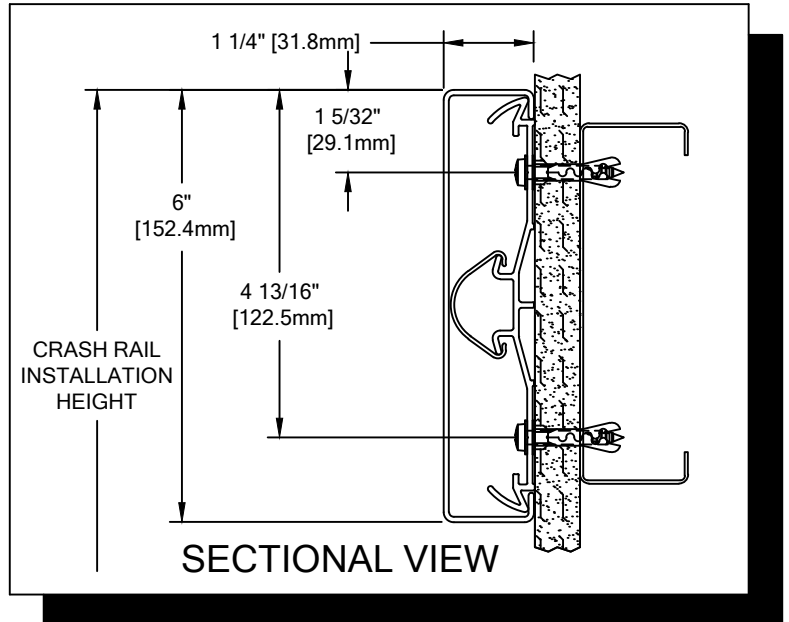

IMPORTANT NOTES

1. ALL LINEAL MATERIAL TO BE SUPPLIED IN STOCK LENGTHS. ALUMINUM AND ACROVYN IN 20'-0" LENGTHS. THIS MATERIAL IS TO BE FIELD CUT USING QUALITY EQUIPMENT TO INSURE THAT ALL CUTS ARE SQUARE. WHEN CUTTING MATERIAL SECTIONS, C/S RECOMMENDS USING AN 80-100 TOOTH CARBIDE TIPPED SAW BLADE OR EQUIVALENT, TO MINIMIZE CHIPPING AND MAINTAIN JOINT ALIGNMENT.
2. ALL DIMENSIONS ARE TYPICAL.
3. FOR DRYWALL/PLASTER WALL CONSTRUCTION, IT IS RECOMMENDED FOR FASTENERS TO BE ENGAGED INTO METAL/WOOD STUDS TO MAINTAIN MAXIMUM PULLOUT STRENGTH.
4. AF-6 PLASTIC ANCHORS SHOULD SEAT FLUSH WITH GYPSUM WALL.
5. MATERIAL MUST REACH 65°F MIN. TO 75°F MAX. 24 HOURS PRIOR TO INSTALLATION. THIS IS ESSENTIAL TO MINIMIZE EXPANSION AND CONTRACTION OF MATERIAL.
6. THE DISTANCE BETWEEN AN ACROVYN SPLICE JOINT AND AN ALUMINUM RETAINER SPLICE JOINT SHOULD BE STAGGERED 1" [25.4mm].

SCR-48MN CRASH RAIL

COMPONENTS & WALL FASTENERS

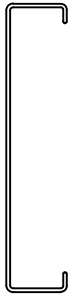

ACROVYN CRASH RAIL COVER
(24U031xxx)

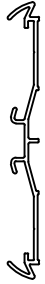

ACROVYN CRASH RAIL RETAINER
(24A307000)



CONTINUOUS VINYL BUMPER
(24U804108)



ACROVYN SPLICE COVER
(24F227108)

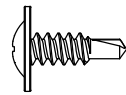

FASTENER #1
#8 x 1/2"
PHILLIPS WAFER HEAD TEK SCREW
(90H086002)

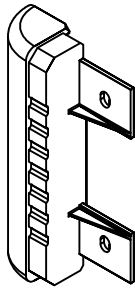

CRASH RAIL END CAP
(24I119xxx)

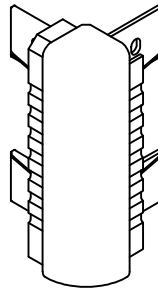

CRASH RAIL OUTSIDE CORNER ASSEMBLY

WALL CONDITION	SPECIFIED FASTENER	DRILL DIAMETERS		C/S PART NUMBER
		WALL	RETAINER	
CONCRETE/CONCRETE BLOCK	#10 X 1 1/2" PHILLIPS PAN HEAD SMS 1/4" FLAT WASHER SAE AF-6 PLASTIC ANCHOR	1/4"	9/32"	90H189002 90H007003 90H039004
STEEL STUD/GYPSUM WALL	#10 X 1 1/2" PHILLIPS PAN HEAD SMS 1/4" FLAT WASHER SAE AF-6 PLASTIC ANCHOR	1/4"	9/32"	90H189002 90H007003 90H039004
WOOD STUD/GYPSUM WALL	#9 X 2 1/4" WAFER HD PH DRYWALL SCREW 1/4" FLAT WASHER SAE	N/A	N/A	90H421002 90H007003

SCR-48MN CRASH RAIL

LAYOUT VIEW

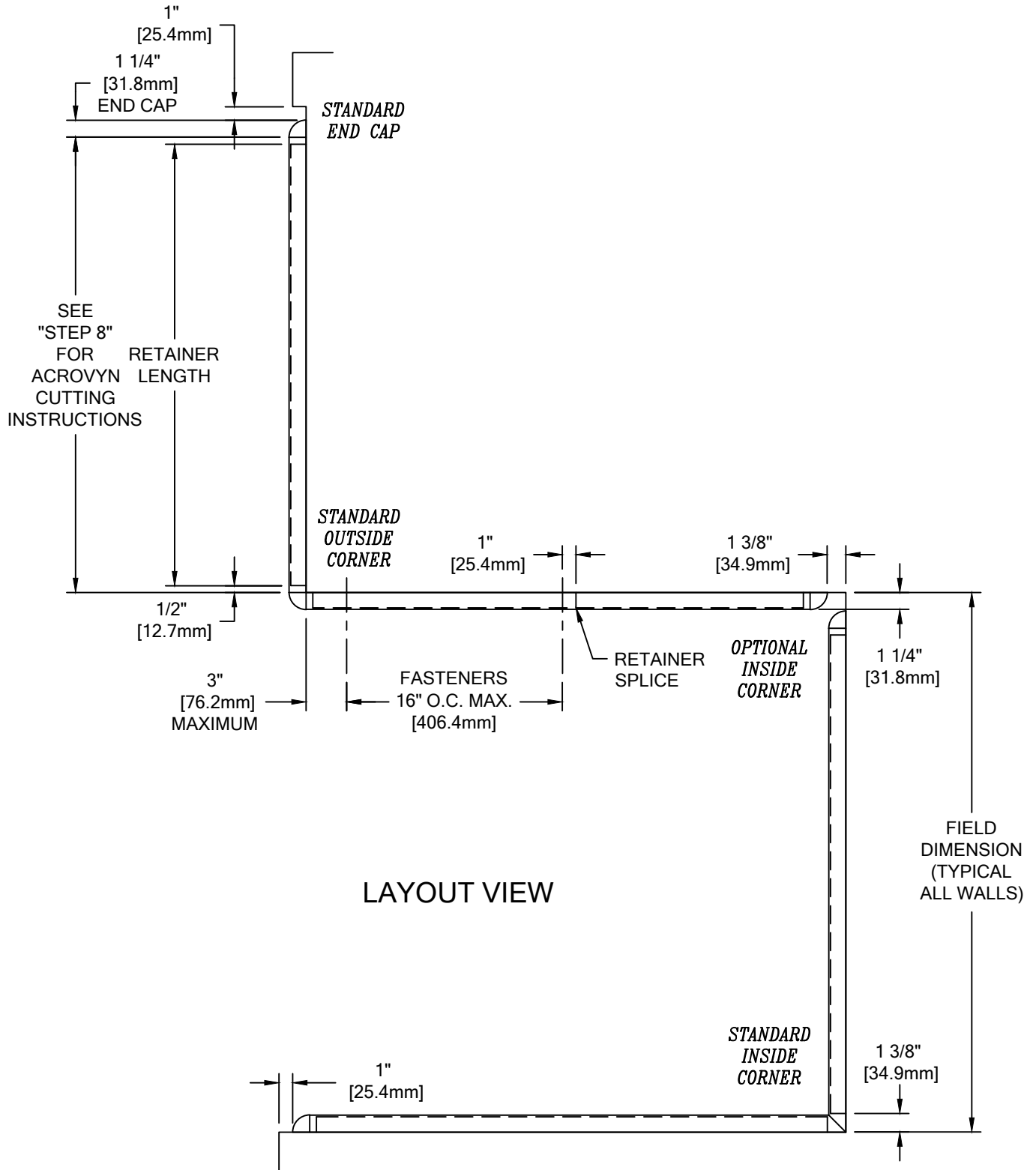

LAYOUT VIEW

SCR-48MN CRASH RAIL

TYPICAL ASSEMBLY

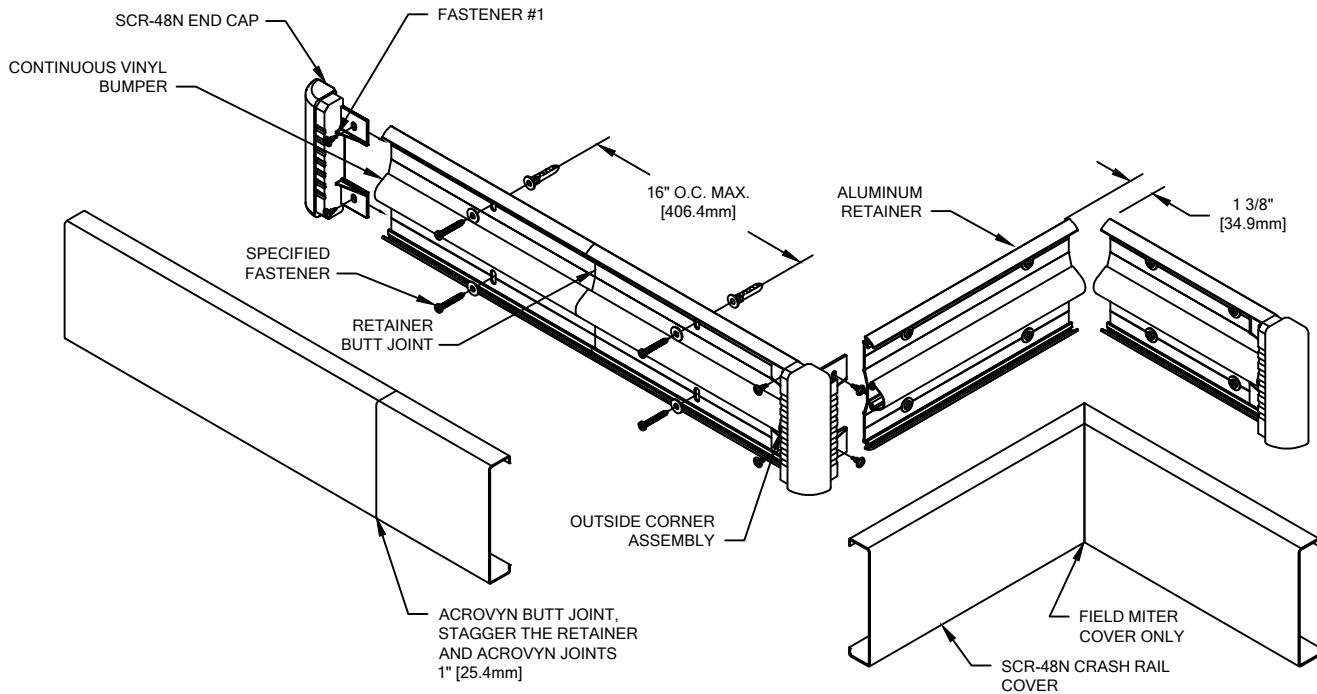

FIGURE 1.

1. ESTABLISH CRASH RAIL HEIGHT ABOVE FINISH FLOOR. DEDUCT 1-5/32" [29.4mm] AND 4-13/16" [122.2mm] AND SNAP A CHALK LINE AT THAT HEIGHT. THIS MARKS THE LOCATION OF THE RETAINER FASTENERS. (SEE SECTIONAL VIEW)
2. CUT THE CONTINUOUS ALUMINUM RETAINER AND THE CONTINUOUS VINYL BUMPER TO LENGTH, USING THE REQUIRED DEDUCTIONS AS NOTED (SEE LAYOUT VIEW). PRE-DRILL CLEARANCE HOLES IN THE ALUMINUM RETAINER 16" [406.4mm] O.C. AS REQUIRED (SEE FIGURE 1), REFERENCE CHART ON PAGE 2 FOR DRILL DIAMETERS.

NOTE: IT IS RECOMMENDED THAT THE ACROVYN COVERS AND ALUMINUM RETAINER BE CUT WITH AN 80-100 TOOTH CARBIDE TIPPED SAW BLADE OR EQUIVALENT.

3. USING THE RETAINER AS A TEMPLATE, MARK THE LOCATION OF THE FASTENERS. USE A LEVEL TO INSURE RETAINER IS PLUMB. DRILL CLEARANCE HOLES IN WALL SURFACE FOR MOUNTING HARDWARE. REFERENCE CHART ON PAGE 2 FOR DRILL DIAMETERS.
4. ATTACH THE CONTINUOUS VINYL BUMPER BY ALIGNING IT WITH THE ALUMINUM RETAINER AND SNAPPING IT INTO PLACE.
5. ATTACH THE ACROVYN SPLICE COVERS AT ALL SPLICE JOINTS BY SNAPPING THEM INTO PLACE ABOVE AND BELOW THE CONTINUOUS VINYL BUMPER. (SEE FIGURE 2)
6. ATTACH END CAPS/OUTSIDE CORNERS BY SLIDING THE END CAP/OUTSIDE CORNER ONTO THE END OF THE ALUMINUM RETAINER AND SECURING INTO POSITION USING TWO 1/2" WAFER HEAD TEK SCREWS AT EACH END CAP AND FOUR AT EACH OUTSIDE CORNER. (SEE FIGURE 1 ABOVE)

NOTE: TO AID IN LOCATING THE END CAPS CORRECTLY, CUT A 4" [101.6mm] SECTION OF GUARD FROM SCRAP AND SNAP IT ON THE RETAINER. LOCATE THE CAP SO IT ALIGNS FLUSH WITH THE TOP AND BOTTOM OF THE GUARD.

SCR-48MN CRASH RAIL

SPLICE COVER ASSEMBLY

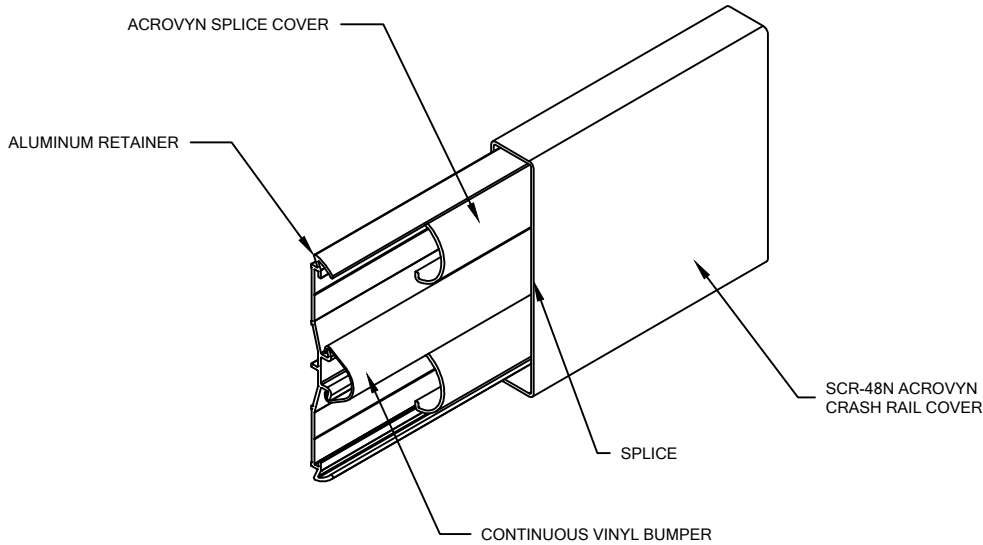

FIGURE 2.

7. INSTALL EACH SECTION OF ASSEMBLED RETAINER, IN SUCCESSION, USING THE APPROPRIATE HARDWARE. USE A LEVEL TO INSURE RETAINER IS PLUMB.
8. CUT THE ACROVYN COVER TO THE PROPER LENGTH. THE COVER LENGTH IS DETERMINED BY MEASURING THE DISTANCE BETWEEN THE INSTALLED END CAPS AND/OR OUTSIDE CORNERS.

NOTE: IT IS RECOMMENDED THAT THE ACROVYN COVERS BE CUT SLIGHTLY LONGER (1/32" UP TO 5'-0", 1/16" OVER 5'-0") THAN THE MEASURED DISTANCE. THIS ADDITIONAL LENGTH WILL PROVIDE FOR A TIGHTER GUARD-TO-END CAP FIT.

9. ALIGN THE TOP OF THE ACROVYN COVER WITH THE TOP OF THE ALUMINUM RETAINER AND SNAP THE GUARD ONTO THE BOTTOM SECTION OF THE RETAINER.

NOTE: MANUFACTURER RECOMMENDS ALL PRINTED "PRODUCT IDENTIFICATION" ON THE REAR OF THE ACROVYN PROFILE SHALL BE ORIENTED IN THE SAME DIRECTION DURING INSTALLATION TO ENSURE PROPER ALIGNMENT AT SPLICE BUTT JOINTS.