

FR-225N FEATURE RAIL

PLEASE READ

PLEASE READ THESE INSTRUCTIONS THOROUGHLY PRIOR TO BEGINNING THE FR-225N FEATURE RAIL INSTALLATION!

THIS INSTRUCTION SHEET IS INTENDED TO PROVIDE A SPECIFIC GUIDE TO FOLLOW FOR THE INSTALLATION OF THIS FR-225N FEATURE RAIL. CONTAINED WITHIN IS THE TECHNICAL INFORMATION AND INSTALLATION TECHNIQUES REQUIRED TO COMPLETE AN EFFICIENT, NEAT AND LONG-LASTING INSTALLATION.

INSPECT ALL MATERIALS FOR DAMAGE OR MISSING PARTS. IF YOU DISCOVER DAMAGED OR MISSING MATERIALS, IN THE USA PLEASE NOTIFY THE FACTORY AT (800) 233-8493, AND IN CANADA (888) 895-8955 FOR CUSTOMER SERVICE.

FR-225N FEATURE RAIL MUST BE INSTALLED IN ACCORDANCE WITH THESE INSTRUCTIONS! FAILURE TO FOLLOW THESE INSTRUCTIONS MAY VOID ANY PRODUCT WARRANTIES AND RESULT IN AN UNSUCCESSFUL INSTALLATION. FOR SPECIFIC QUESTIONS REGARDING THE INSTALLATION OF THIS FR-225N FEATURE RAIL PLEASE CALL THE FACTORY IN THE USA AT (800) 233-8493 OR EMAIL IWPFIELDTECH@C-SGROUP.COM. IN CANADA CALL (888) 895-8955 .

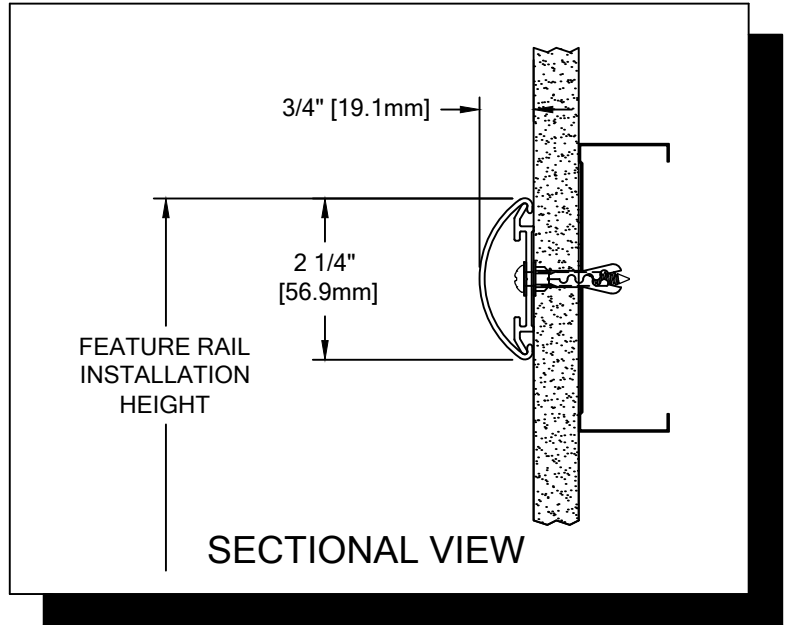

IMPORTANT NOTES

1. ALL LINEAL MATERIAL TO BE SUPPLIED IN STOCK LENGTHS. ALUMINUM AND ACROVYN IN LENGTHS UP TO 20'-0". THIS MATERIAL IS TO BE FIELD CUT USING QUALITY EQUIPMENT TO INSURE THAT ALL CUTS ARE SQUARE. WHEN CUTTING MATERIAL SECTIONS, C/S RECOMMENDS USING AN 80-100 TOOTH CARBIDE TIPPED SAW BLADE OR EQUIVALENT, TO MINIMIZE CHIPPING AND MAINTAIN JOINT ALIGNMENT.
2. ALL DIMENSIONS ARE TYPICAL.
3. FOR DRYWALL/PLASTER WALL CONSTRUCTION, IT IS RECOMMENDED FOR FASTENERS TO BE ENGAGED INTO METAL/WOOD STUDS TO MAINTAIN MAXIMUM PULLOUT STRENGTH.
4. MATERIAL MUST REACH 65°F MIN. TO 75°F MAX. 24 HOURS PRIOR TO INSTALLATION. THIS IS ESSENTIAL TO MINIMIZE EXPANSION AND CONTRACTION OF MATERIAL.
5. THE DISTANCE BETWEEN AN ACROVYN SPLICE JOINT AND AN ALUMINUM RETAINER SPLICE JOINT SHOULD BE STAGGERED 4" [101.6mm].

FR-225N FEATURE RAIL

COMPONENTS & WALL FASTENERS



ACROVYN COVER
(24U084xxx)
ACROVYN CHAMELEON COVER
(24U692xxx)



ALUMINUM RETAINER
(24A215000)



END CAP
(241095xxx)
CHAMELEON END CAP
(241684xxx)

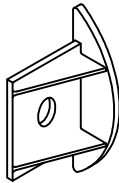

OUTSIDE CORNER FLANGE
(241096000)



ACCENT REVEAL
(241829xxx)

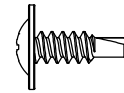

FASTENER #1
#8 X 1/2"
PHILLIPS WAFER
HEAD TEK SCREW
(90H086002)

WALL CONDITION	SPECIFIED FASTENER	DRILL DIAMETERS		C/S PART NUMBER
		WALL	RETAINER	
STEEL STUD/GYPSUM WALL	#10 x 1 1/2" PHILLIPS PAN HEAD SMS 1/4" FLAT WASHER STEEL PLATED SAE AF-6 PLASTIC ANCHORS	1/4"	5/16"	90H189002 90H007003 90H039004
CONCRETE/CONCRETE BLOCK	#10 x 1 1/2" PHILLIPS PAN HEAD SMS 1/4" FLAT WASHER STEEL PLATED SAE AF-6 PLASTIC ANCHORS	1/4"	9/32"	90H189002 90H007003 90H039004
WOOD STUD/GYPSUM WALL	#9 X 2 1/4" PHILLIPS WAFER HEAD DRYWALL SCREW	N/A	N/A	90H421002

FR-225N FEATURE RAIL

LAYOUT VIEW

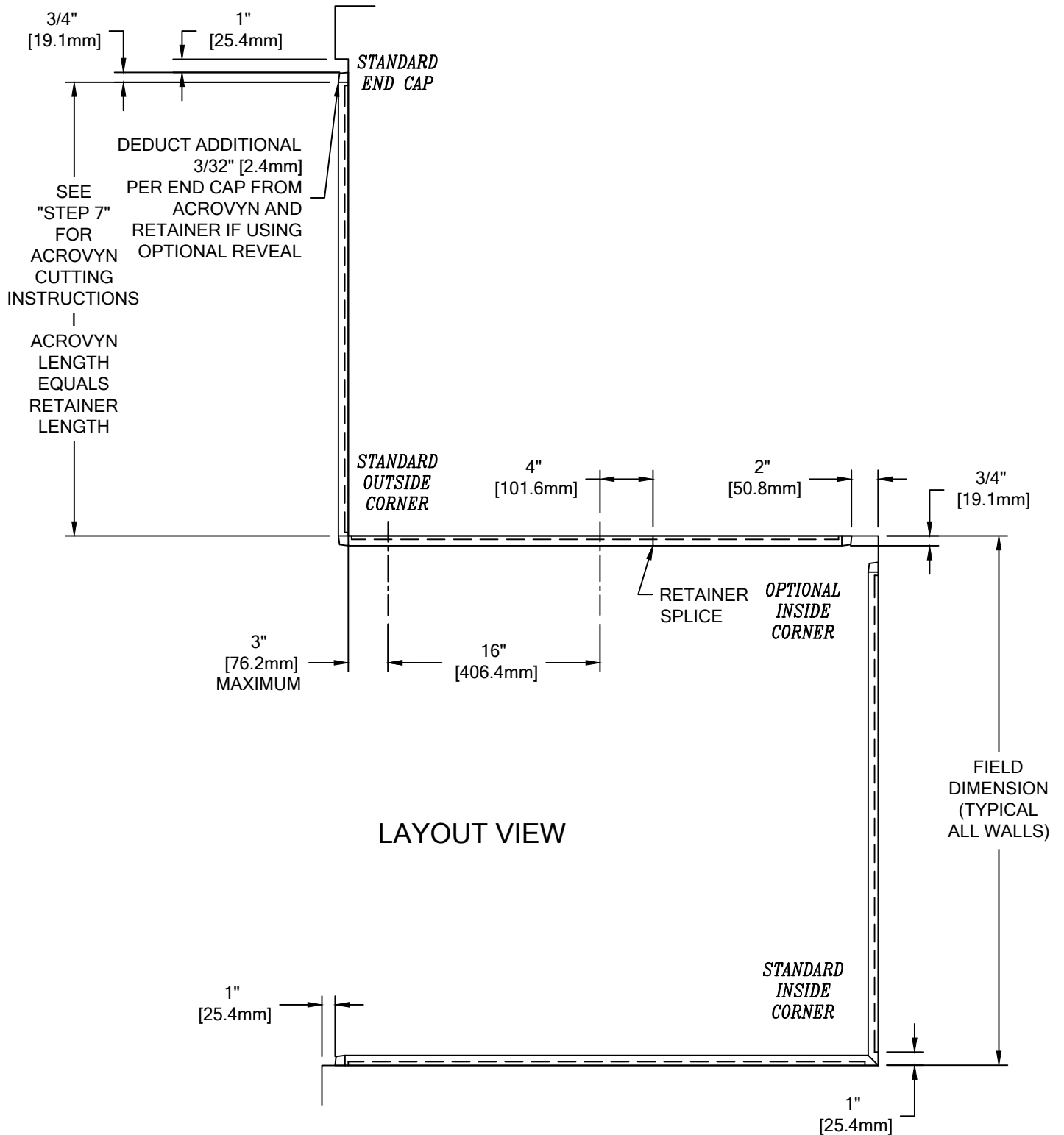

FR-225N FEATURE RAIL

TYPICAL ASSEMBLY

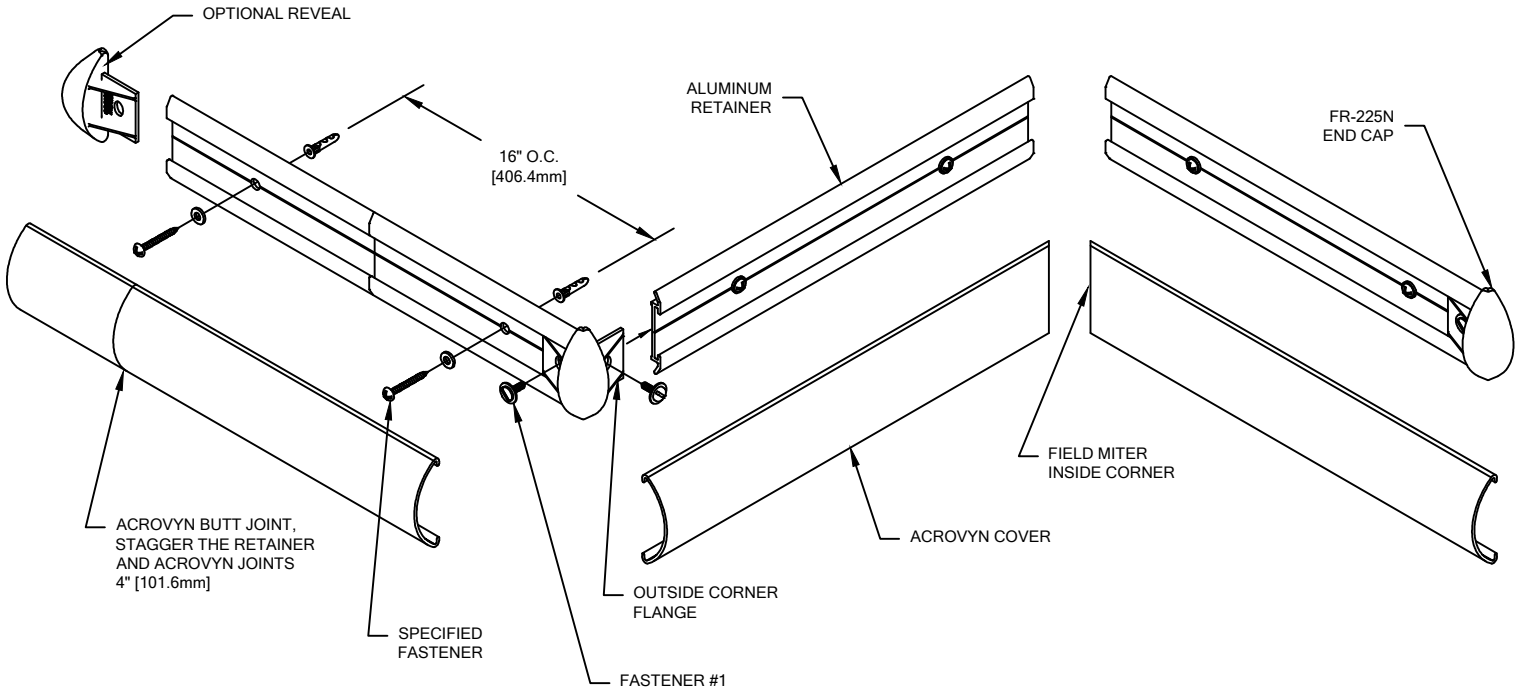

1. ESTABLISH FEATURE RAIL HEIGHT ABOVE FINISH FLOOR. DEDUCT 1-1/8" [28.6mm] AND SNAP A CHALK LINE AT THAT HEIGHT. THIS MARKS THE LOCATION OF THE FASTENERS FOR THE ALUMINUM RETAINER.
2. CUT THE CONTINUOUS ALUMINUM RETAINER TO LENGTH NOTING THE REQUIRED DEDUCTIONS AS NOTED (SEE LAYOUT VIEW). PRE-DRILL CLEARANCE HOLES IN THE ALUMINUM RETAINER 16" [406.4mm] O.C., ALONG THE V-GROOVE AS REQUIRED. REFERENCE CHART ON PAGE 2 FOR CORRECT DRILL DIAMETERS.

NOTE: IT IS RECOMMENDED THAT THE ACROVYN COVERS AND ALUMINUM RETAINER BE CUT WITH AN 80-100 TOOTH CARBIDE TIPPED SAW BLADE OR EQUIVALENT.

3. USING THE RETAINER AS A TEMPLATE, MARK THE LOCATION OF THE FASTENERS ALONG THE CHALK LINE. USE A LEVEL TO INSURE RETAINER IS PLUMB. DRILL CLEARANCE HOLES IN WALL SURFACE FOR MOUNTING HARDWARE. REFERENCE CHART ON PAGE 2 FOR CORRECT DRILL DIAMETERS.
4. INSTALL EACH SECTION OF RETAINER ONTO THE WALL, IN SUCCESSION, USING THE APPROPRIATE HARDWARE. USE A LEVEL TO ENSURE THE RETAINER IS LEVEL.
5. ATTACH END CAPS/OUTSIDE CORNERS BY SLIDING THE END CAP/OUTSIDE CORNER ONTO THE END OF THE ALUMINUM RETAINER AND SECURING INTO POSITION WITH ONE (1) #8 X 1/2" WAFER HEAD TEK SCREWS AT EACH END CAP AND TWO (2) AT EACH OUTSIDE CORNER.

NOTE: TO AID IN LOCATING THE END CAPS CORRECTLY, CUT A 4" [101.6mm] SECTION OF GUARD FROM SCRAP AND SNAP IT ON THE RETAINER. LOCATE THE CAP SO IT ALIGNS FLUSH WITH TOP AND BOTTOM OF THE GUARD.

6. CUT THE ACROVYN COVER TO THE PROPER LENGTH. THE COVER LENGTH IS DETERMINED BY MEASURING THE DISTANCE BETWEEN THE INSTALLED END CAPS AND/OR OUTSIDE CORNER ASSEMBLIES.

NOTE: IT IS RECOMMENDED THAT THE ACROVYN COVERS BE CUT SLIGHTLY LONGER (1/32" [0.8mm] UP TO 5'-0" [1.5m], 1/16" [1.6mm] OVER 5'-0" [1.5m]) THAN THE MEASURED DISTANCE. THIS ADDITIONAL LENGTH WILL PROVIDE FOR A TIGHTER GUARD-TO-END CAP FIT.

7. ALIGN THE TOP OF THE ACROVYN COVER WITH THE TOP OF THE RETAINER AND SNAP THE GUARD ONTO THE BOTTOM SECTION OF RETAINER.

NOTE: MANUFACTURER RECOMMENDS ALL PRINTED "PRODUCT IDENTIFICATION" ON THE REAR OF THE ACROVYN PROFILE SHALL BE ORIENTED IN THE SAME DIRECTION DURING INSTALLATION TO ENSURE PROPER ALIGNMENT AT SPLICE BUTT JOINTS.

10/20/11