

ECR-64 CRASH RAIL

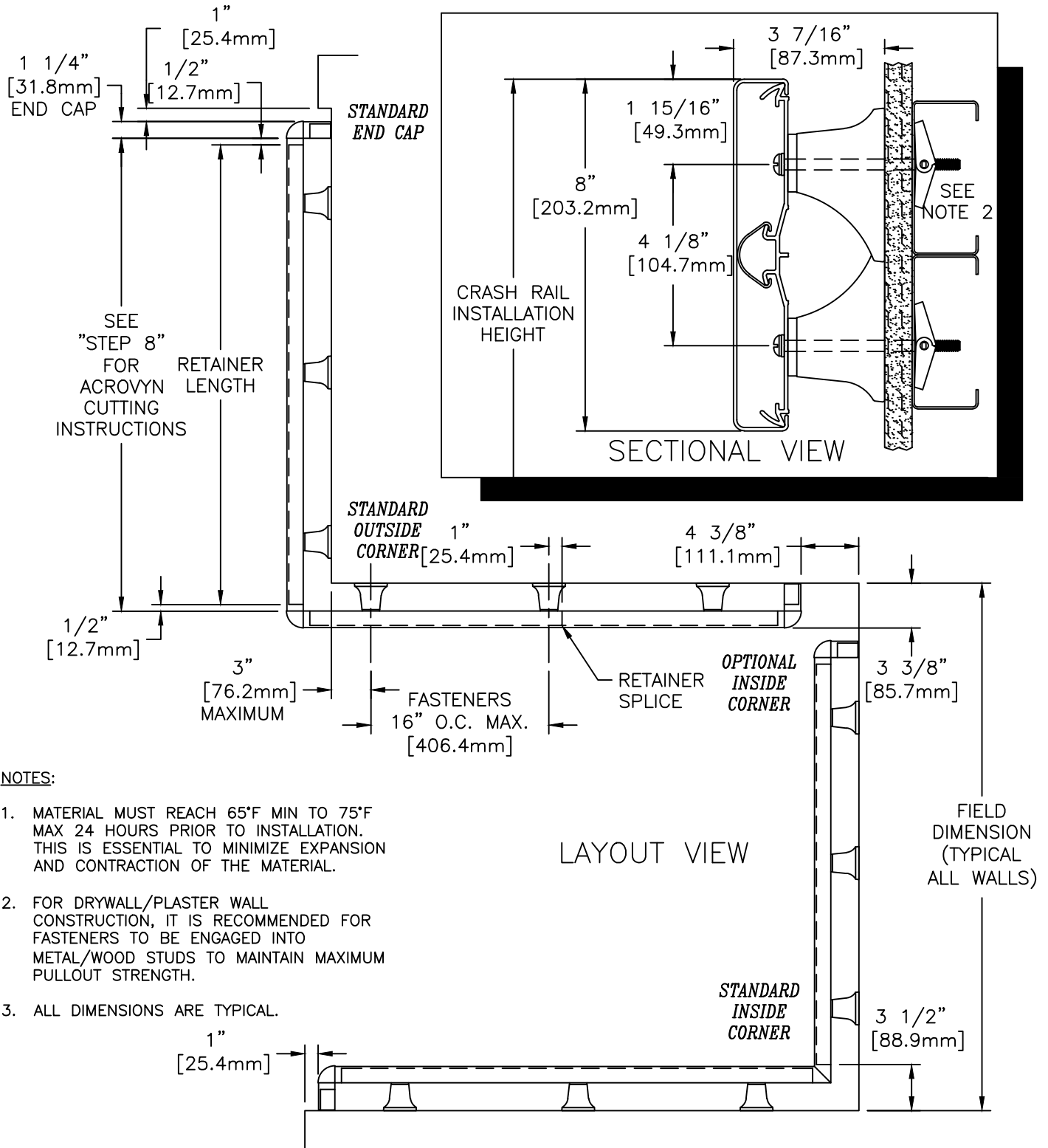

NOTES:

1. MATERIAL MUST REACH 65°F MIN TO 75°F MAX 24 HOURS PRIOR TO INSTALLATION. THIS IS ESSENTIAL TO MINIMIZE EXPANSION AND CONTRACTION OF THE MATERIAL.
2. FOR DRYWALL/PLASTER WALL CONSTRUCTION, IT IS RECOMMENDED FOR FASTENERS TO BE ENGAGED INTO METAL/WOOD STUDS TO MAINTAIN MAXIMUM PULLOUT STRENGTH.
3. ALL DIMENSIONS ARE TYPICAL.

ECR-64 CRASH RAIL



ACROVYN CRASH RAIL COVER (24U042xxx)



ACROVYN CRASH RAIL RETAINER (24A308000)



CONTINUOUS VINYL BUMPER (24U804108)



FR270 ACROVYN COVER SPLICE (24F227108)

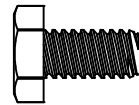

FASTENER #1
1/4-20 X 1/2" HEX HEAD MACHINE SCREW (90H052002)

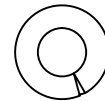

FASTENER #2
1/4" LOCK WASHER (90H006003)

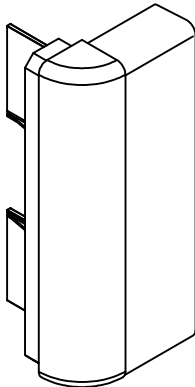

CRASH RAIL ENDCAP ASSEMBLY (ECR64CAPxxx)

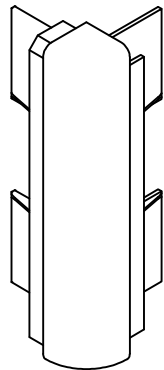

CRASH RAIL OUTSIDE CORNER ASSEMBLY

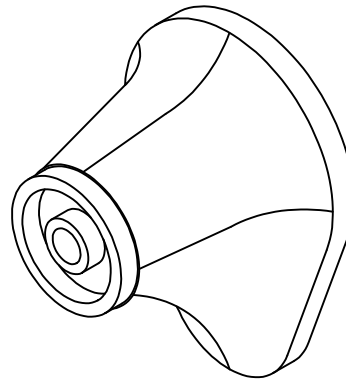

MOUNTING BRACKET (24I007xxx)

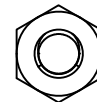

FASTENER #3
1/4-20 HEX NUT (90H010001)

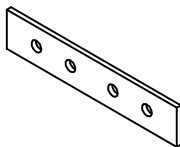

CRASH RAIL RETAINER SPLICE BAR (24I976000)

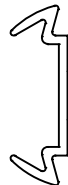

FR270 SPLICE RETAINER (24F228000)

WALL CONDITION	SPECIFIED FASTENER	DRILL DIAMETERS		C/S PART NUMBER
		WALL	RETAINER	
STEEL STUD/GYPSUM WALL	1/4-20 X 5" RD HD TOGGLE BOLT 1/4" FLAT WASHER SAE	3/4"	9/32"	90H049002 90H007003
CONCRETE/CONC. BLOCK	#14 X 5" PHILLIPS ROUND HEAD AP SCREW 1/4" FLAT WASHER SAE	3/16"	9/32"	90H287002 90H007003
WOOD STUD/GYPSUM WALL	#14 X 5" PHILLIPS ROUND HEAD AP SCREW 1/4" FLAT WASHER SAE	1/8"	9/32"	90H287002 90H007003

ECR-64 CRASH RAIL

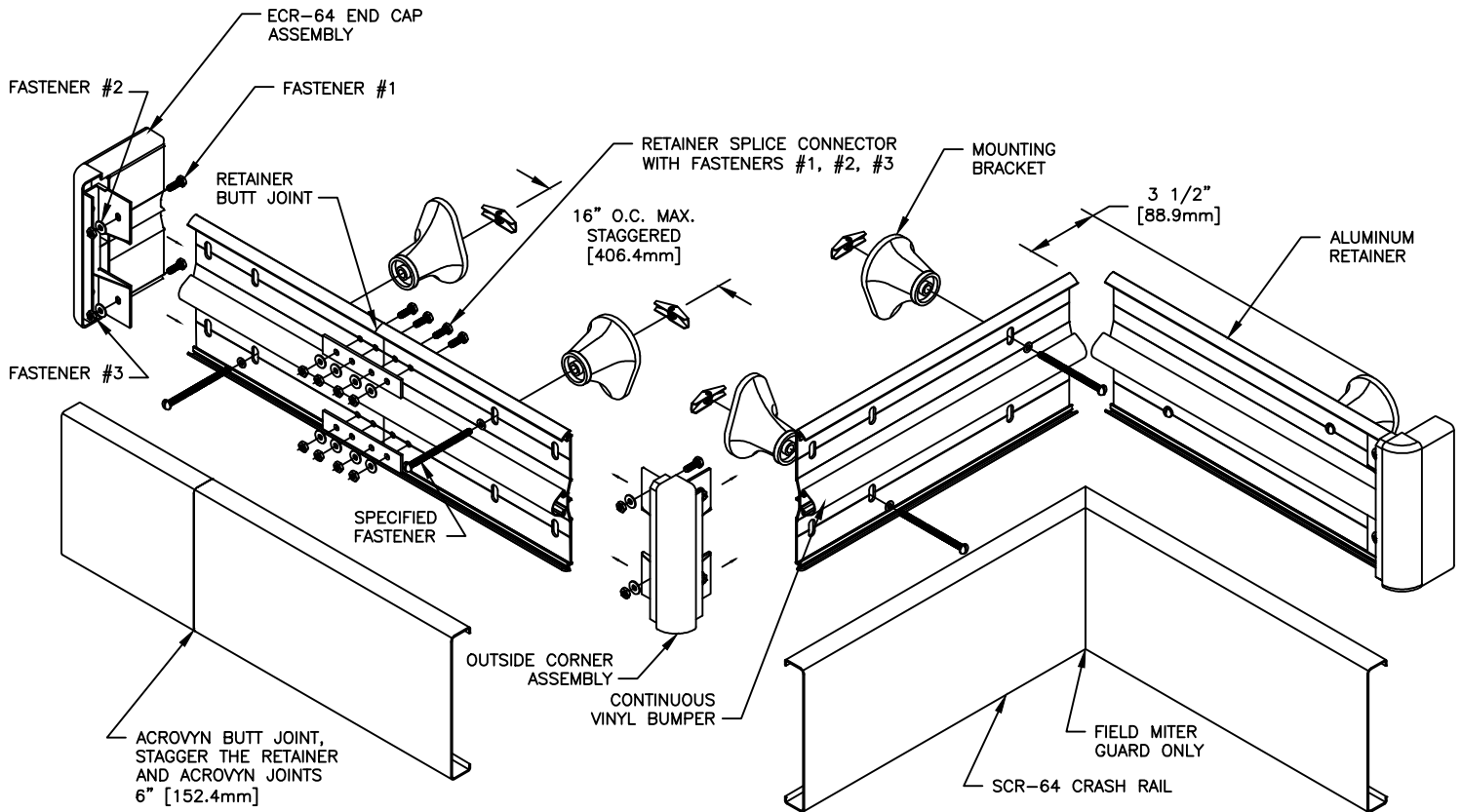

FIGURE 1.

1. ESTABLISH CRASH RAIL HEIGHT ABOVE FINISH FLOOR. DEDUCT 1-13/16" [46.6mm] AND SNAP A CHALK LINE AT THAT HEIGHT. THIS MARKS THE LOCATION OF THE RETAINER FASTENERS. (SEE SECTIONAL VIEW)
2. CUT THE CONTINUOUS ALUMINUM RETAINER AND THE CONTINUOUS VINYL BUMPER TO LENGTH, USING THE REQUIRED DEDUCTIONS AS NOTED (SEE LAYOUT VIEW). PRE-DRILL CLEARANCE HOLES IN THE ALUMINUM RETAINER 16" [406.4mm] O.C., STAGGERED AS REQUIRED (SEE FIGURE 1)(SEE NOTE 2 AND CHART ON PAGE 2).

NOTE: IT IS RECOMMENDED THAT THE ACROVYN COVERS AND ALUMINUM RETAINER BE CUT WITH A 100 TOOTH CARBIDE TIPPED SAW BLADE OR EQUIVALENT.

3. USING THE RETAINER AS A TEMPLATE, MARK THE LOCATION OF THE FASTENERS (SEE NOTE 2). DRILL CLEARANCE HOLES IN WALL SURFACE FOR MOUNTING HARDWARE (SEE CHART ON PAGE 2). USE A LEVEL TO ENSURE RETAINER IS PLUMB.
4. ATTACH THE CONTINUOUS VINYL BUMPER BY ALIGNING IT WITH THE ALUMINUM RETAINER AND SNAPPING IT INTO PLACE.
5. ATTACH THE 4" LONG FR-270 COVERS TO THE APPROPRIATE RETAINERS BY SNAPPING THEM INTO PLACE. REMOVE THE PROTECTIVE COVERING FROM THE FACTORY APPLIED ADHESIVE AND ATTACH THE ASSEMBLY TO THE RETAINER AT ALL ACROVYN SPLICE JOINTS. (SEE FIGURE 2)
6. ATTACH END CAPS/OUTSIDE CORNERS BY SLIDING THE END CAP/OUTSIDE CORNER ONTO THE END OF THE ALUMINUM RETAINER AND SECURING INTO POSITION USING TWO 1/4-20 x 1/2" HEX HEAD MACHINE SCREW WITH LOCK WASHER AND NUT AT EACH END CAP AND FOUR AT EACH OUTSIDE CORNER (SEE DETAIL ABOVE).

NOTE: TO AID IN LOCATING THE END CAPS CORRECTLY, CUT A 4" [101.6mm] SECTION OF GUARD FROM SCRAP AND SNAP IT ON THE RETAINER. LOCATE THE CAP SO IT ALIGNS FLUSH WITH TOP AND BOTTOM OF THE GUARD.

ECR-64 CRASH RAIL

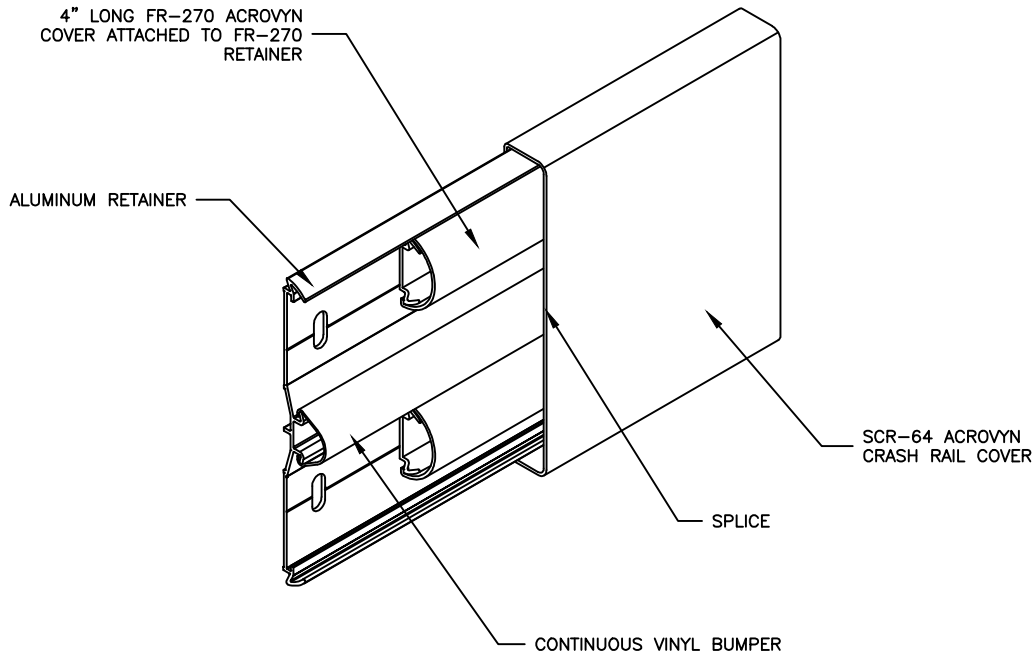

FIGURE 2.

7. INSTALL EACH SECTION OF ASSEMBLED RETAINER, IN SUCCESSION, USING THE MOUNTING BRACKETS AND THE APPROPRIATE HARDWARE. USE A LEVEL TO ENSURE RETAINER IS PLUMB.
8. CUT THE ACROVYN COVER TO THE PROPER LENGTH. THE GUARD LENGTH IS DETERMINED BY MEASURING THE DISTANCE BETWEEN THE INSTALLED END CAPS AND/OR INSIDE/OUTSIDE CORNER ASSEMBLIES.

NOTE: IT IS RECOMMENDED THAT THE ACROVYN GUARDS BE CUT SLIGHTLY LONGER ($1/32$ " UP TO 5'-0", $1/16$ " OVER 5'-0") THAN THE MEASURED DISTANCE. THIS ADDITIONAL LENGTH WILL PROVIDE FOR A TIGHTER GUARD-TO-END CAP FIT.

9. ALIGN THE TOP OF THE ACROVYN COVER WITH THE TOP OF THE ALUMINUM RETAINER AND SNAP THE GUARD ONTO THE BOTTOM SECTION OF THE RETAINER.

NOTE: MANUFACTURER RECOMMENDS ALL PRINTED "PRODUCT IDENTIFICATION" ON THE REAR OF THE ACROVYN PROFILE SHALL BE ORIENTED IN THE SAME DIRECTION DURING INSTALLATION TO ENSURE PROPER ALIGNMENT AT SPLICE BUTT JOINTS.

05/06/10