

FR-125 FEATURE RAIL

PLEASE READ

PLEASE READ THESE INSTRUCTIONS THOROUGHLY PRIOR TO BEGINNING THE FR-125 FEATURE RAIL INSTALLATION!

THIS INSTRUCTION SHEET IS INTENDED TO PROVIDE A SPECIFIC GUIDE TO FOLLOW FOR THE INSTALLATION OF THIS FR-125 FEATURE RAIL. CONTAINED WITHIN IS THE TECHNICAL INFORMATION AND INSTALLATION TECHNIQUES REQUIRED TO COMPLETE AN EFFICIENT, NEAT AND LONG-LASTING INSTALLATION.

INSPECT ALL MATERIALS FOR DAMAGE OR MISSING PARTS. IF YOU DISCOVER DAMAGED OR MISSING MATERIALS, IN THE USA PLEASE NOTIFY THE FACTORY AT (800) 233-8493, AND IN CANADA (888) 895-8955 FOR CUSTOMER SERVICE.

FR-125 FEATURE RAIL MUST BE INSTALLED IN ACCORDANCE WITH THESE INSTRUCTIONS! FAILURE TO FOLLOW THESE INSTRUCTIONS MAY VOID ANY PRODUCT WARRANTIES AND RESULT IN AN UNSUCCESSFUL INSTALLATION. FOR SPECIFIC QUESTIONS REGARDING THE INSTALLATION OF THIS FR-125 FEATURE RAIL PLEASE CALL THE FACTORY IN THE USA AT (800) 233-8493 OR EMAIL IWPFIELDTECH@C-SGROUP.COM. IN CANADA CALL (888) 895-8955 .

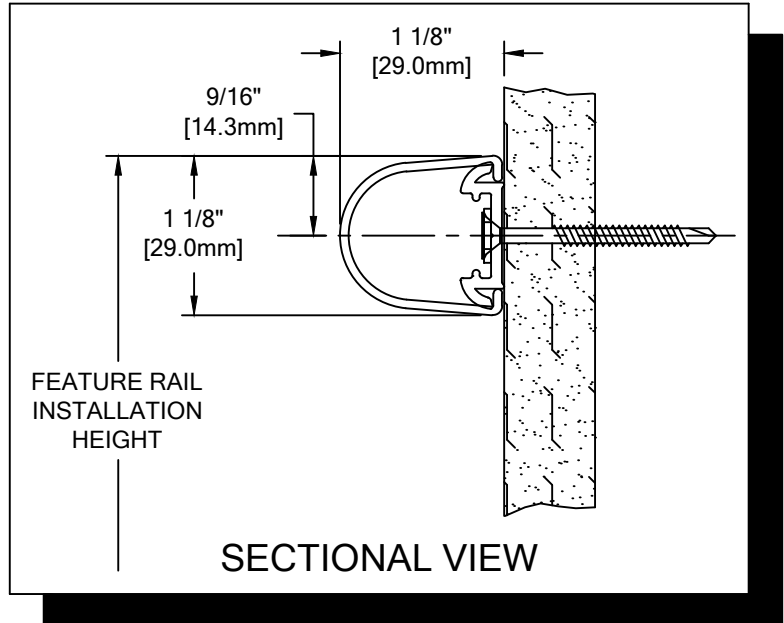

IMPORTANT NOTES

1. ALL LINEAL MATERIAL TO BE SUPPLIED IN STOCK LENGTHS. ALUMINUM AND ACROVYN IN 12'-0" LENGTHS. THIS MATERIAL IS TO BE FIELD CUT USING QUALITY EQUIPMENT TO INSURE THAT ALL CUTS ARE SQUARE. WHEN CUTTING MATERIAL SECTIONS, C/S RECOMMENDS USING AN 80-100 TOOTH CARBIDE TIPPED SAW BLADE OR EQUIVALENT, TO MINIMIZE CHIPPING AND MAINTAIN JOINT ALIGNMENT.
2. ALL DIMENSIONS ARE TYPICAL.
3. FOR DRYWALL/PLASTER WALL CONSTRUCTION, IT IS RECOMMENDED FOR FASTENERS TO BE ENGAGED INTO METAL/WOOD STUDS TO MAINTAIN MAXIMUM PULLOUT STRENGTH.
4. MATERIAL MUST REACH 65°F MIN. TO 75°F MAX. 24 HOURS PRIOR TO INSTALLATION. THIS IS ESSENTIAL TO MINIMIZE EXPANSION AND CONTRACTION OF MATERIAL.
5. THE DISTANCE BETWEEN AN ACROVYN SPLICE JOINT AND AN ALUMINUM RETAINER SPLICE JOINT SHOULD BE STAGGERED 4" [101.6mm].
6. AF-6 PLASTIC ANCHORS SHOULD SEAT FLUSH WITH GYPSUM WALL.

FR-125 FEATURE RAIL

COMPONENTS & WALL FASTENERS

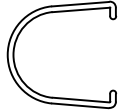

ACROVYN COVER
(23U013xxx)



ALUMINUM RETAINER
(24A309000)

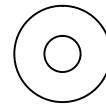

FASTENER #1
#8 SAE FLAT WASHER
(90H010003)

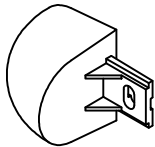

FEATURE RAIL END CAP
(23I007xxx)

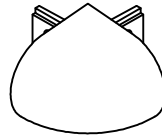

FEATURE RAIL
OUTSIDE CORNER ASSEMBLY

| WALL CONDITION | SPECIFIED FASTENER | DRILL DIAMETERS | | C/S PART NUMBER |
|-------------------------|---|-----------------|----------|------------------------|
| | | WALL | RETAINER | |
| STEEL STUD/GYPSUM WALL | #6 x 1 5/8" BUGLE HEAD SELF-DRILLING S.M.S. | N/A | 1/8" | 90H079002 |
| CONCRETE/CONCRETE BLOCK | #10 x 1 1/2" PHILLIPS PAN HEAD S.M.S. AF-6 PLASTIC ANCHORS | 1/4" | 1/8" | 90H189002 90H039004 |
| WOOD STUD/GYPSUM WALL | #6 x 1 5/8" BUGLE HEAD SELF-DRILLING S.M.S. | N/A | 1/8" | 90H079002 |

FR-125 FEATURE RAIL

LAYOUT VIEW

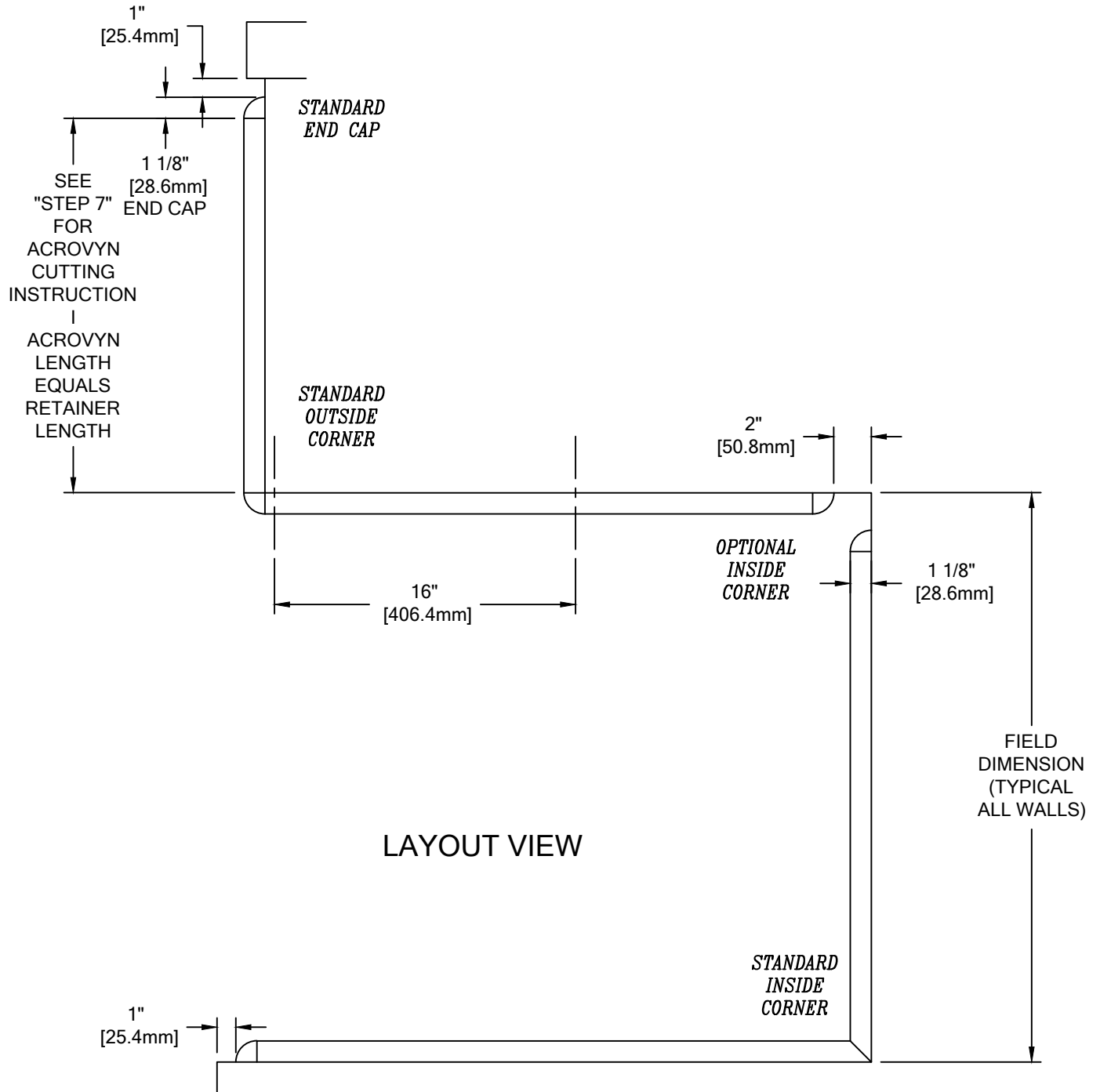

LAYOUT VIEW

FR-125 FEATURE RAIL

TYPICAL ASSEMBLY

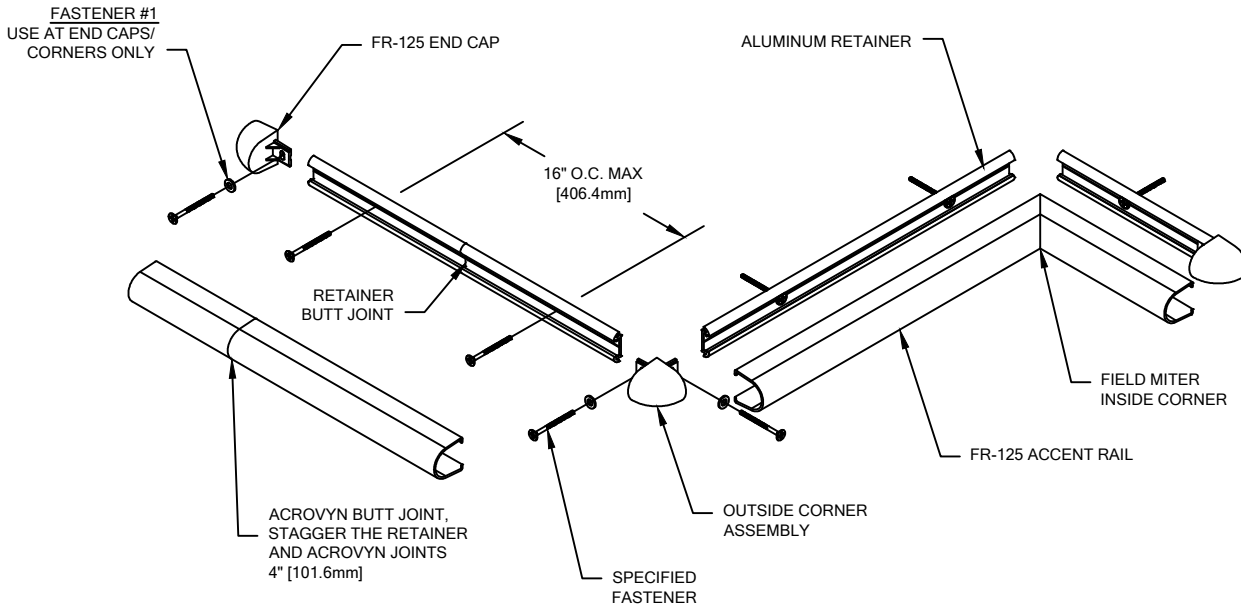

1. ESTABLISH ACCENT RAIL HEIGHT ABOVE FINISH FLOOR. DEDUCT 9/16" [14.3mm] AND SNAP A CHALK LINE AT THAT HEIGHT. THIS MARKS THE LOCATION OF THE RETAINER FASTENERS.
2. CUT THE CONTINUOUS ALUMINUM RETAINER TO LENGTH USING THE REQUIRED DEDUCTIONS AS NOTED (SEE LAYOUT VIEW). PRE-DRILL CLEARANCE HOLES IN THE ALUMINUM RETAINER 16" [406.4mm] O.C., ALONG THE V-GROOVE AS REQUIRED. REFERENCE CHART ON PAGE 2 FOR DRILL DIAMETERS.

NOTE: IT IS RECOMMENDED THAT THE ACROVYN COVERS AND ALUMINUM RETAINER BE CUT WITH AN 80-100 TOOTH CARBIDE TIPPED SAW BLADE OR EQUIVALENT.

3. USING THE RETAINER AS A TEMPLATE, MARK THE LOCATION OF THE FASTENERS ALONG THE CHALK LINE. USE A LEVEL TO INSURE THE RETAINER IS PLUMB. DRILL CLEARANCE HOLES IN WALL SURFACE FOR MOUNTING HARDWARE. REFERENCE CHART ON PAGE 2 FOR DRILL DIAMETERS.
4. INSTALL EACH SECTION OF RETAINER ONTO THE WALL, IN SUCCESSION, USING THE APPROPRIATE HARDWARE. USE A LEVEL TO INSURE THAT RETAINER IS LEVEL.
5. ATTACH EACH END CAP/OUTSIDE CORNER BY SLIDING THE END CAP/OUTSIDE CORNER WITH THE END OF THE ALUMINUM RETAINER AND SECURING INTO POSITION WITH ONE (1) SPECIFIED FASTENER AT EACH END CAP AND TWO (2) AT EACH OUTSIDE CORNER. USE A FLAT WASHER WITH THE FASTENER TO PREVENT DAMAGE TO THE ALIGNMENT TABS. USE A LIMITED AMOUNT OF TORQUE WHEN USING POWER DRIVERS.
6. CUT THE ACROVYN COVER TO THE PROPER LENGTH. THE COVER LENGTH IS DETERMINED BY MEASURING THE DISTANCE BETWEEN THE INSTALLED END CAPS AND/OR OUTSIDE CORNER ASSEMBLIES.

NOTE: IT IS RECOMMENDED THAT THE ACROVYN COVERS BE CUT SLIGHTLY LONGER (1/32" UP TO 5'0", 1/16" OVER 5'0" THAN THE MEASURED DISTANCE. THIS ADDITIONAL LENGTH WILL PROVIDE FOR A TIGHTER GUARD-TO-END CAP FIT.

7. ALIGN THE TOP OF THE ACROVYN COVER WITH THE TOP OF THE RETAINER AND SNAP THE GUARD ONTO THE BOTTOM SECTION OF RETAINER.

NOTE: MANUFACTURER RECOMMENDS ALL PRINTED "PRODUCT IDENTIFICATION" ON THE REAR OF THE ACROVYN PROFILE SHALL BE ORIENTED IN THE SAME DIRECTION DURING INSTALLATION TO ENSURE PROPER ALIGNMENT AT SPLICE BUT JOINTS.

10/20/11