

COLOR: _____
 COLOR TO BE SELECTED FROM ONE OF C/S STANDARD COLORS

QTY. REQ'D	HGT. REQ'D	COLOR

1. PREPARE OUTSIDE CORNER FOR GUARD INSTALLATION BY REMOVING ANY OIL OR DUST USING "ACROVYN INTERIORS CLEANER".
2. REMOVE THE PROTECTIVE COVERING FROM THE FOAM TAPE LOCATED ON THE REAR OF EACH LEG OF THE CORNER GUARD.
3. INSTALL THE CORNER GUARD BY ALIGNING THE BOTTOM OF THE CORNER GUARD WITH THE TOP OF THE COVE BASE OR FINISH FLOOR AND MOVING THE GUARD INTO POSITION ALONG THE APEX OF THE WALL SURFACE AND CORNER GUARD.
4. COMPLETE INSTALLATION BY SECURING THE CORNER GUARD TO THE WALL SURFACE BY RUBBING EACH LEG WITH A CLEAN SOFT CLOTH. APPLY MEDIUM HAND PRESSURE TO ENSURE MAXIMUM ADHESION TO THE WALL SURFACE.
5. IF CORNER GUARDS ARE TO BE MECHANICALLY FASTENED, DRILLING TO BE DONE IN FIELD.

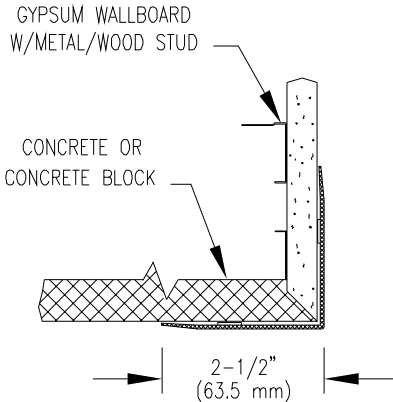
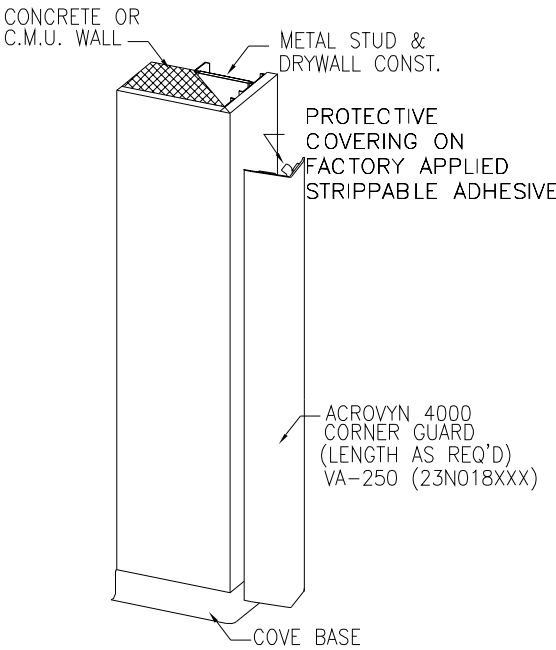

VA-250 N

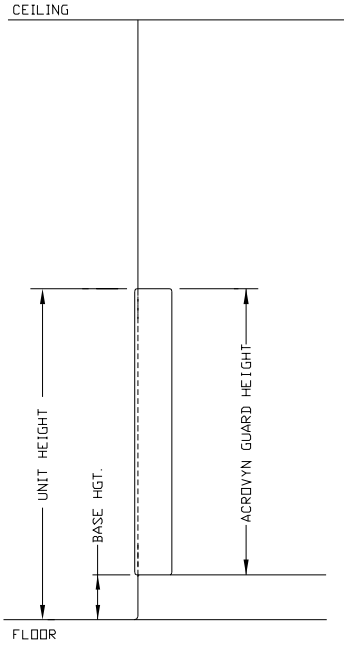

VA-250 GUARD AT PARTIAL HEIGHT ELEVATION



PROJECT:		REV. :
LOCATION:		F&F:
CUSTOMER:		SHEET OF
AGENT:		JOB NO.
DWG. BY:	DATE:	