

COLOR: _____
 COLOR TO BE SELECTED FROM ONE OF C/S
 STANDARD COLORS

QTY. REQ'D	UNIT HEIGHT	RET. LENGTH	COVER LENGTH

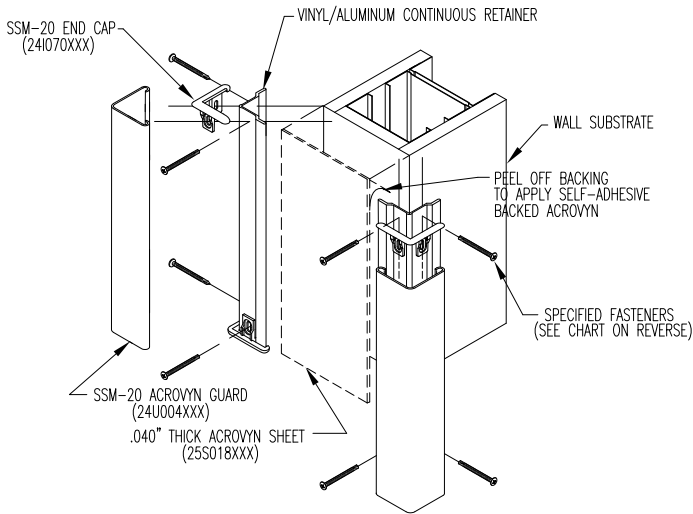

1. ESTABLISH CORNER GUARD HEIGHT REQUIREMENT. CUT RETAINER (ALUMINUM OR VINYL) 5/8"(15.9mm) LESS THAN THE OVERALL HEIGHT DIMENSION. CUT .040 ACROVYN SHEET TO THE OVERALL CORNER GUARD HEIGHT.
2. PLACE SELF-ADHESIVE BACKED ACROVYN STRIP IN PLACE ON END WALL OR CHANNEL. PEEL BACKING APPROX. 2" (50.8mm) FROM TOP AND PLACE IN POSITION AS PREVIOUSLY ESTABLISHED. ALIGN THE EDGE OF THE SHEET ALONG ONE EDGE OF THE END WALL. PEEL THE BACKING DOWNWARD APPLYING PRESSURE AS YOU PROCEED.
3. INSTALL ONE (1) RETAINER AT EACH CORNER ON TOP OF THE ACROVYN, 1/4"(6.4mm) ABOVE COVE BASE OR FINISH FLOOR USING THE REQUIRED FASTENERS AS NOTED ON REVERSE.
4. ALIGN ONE (1) END CAP WITH THE BOTTOM OF EACH RETAINER AND SECURE INTO POSITION USING THE SPECIFIED FASTENER, MAKING SURE THAT THE END CAP ABUTS THE END OF THE RETAINER.
5. REPEAT THE PROCEDURE TO INSTALL THE TOP END CAPS,
6. CUT THE ACROVYN GUARDS 1/8"(3.2mm) LONGER THAN THE LENGTH OF THE RETAINERS.
7. FINISH INSTALLATION BY SNAPPING THE ACROVYN COVERS ONTO THE RETAINERS. ALIGN ONE LEG OF THE COVER WITH ONE LEG OF THE RETAINER AND SNAP THE COVER INTO POSITION BY APPLYING PRESSURE AT THE NOSE OF THE COVER TOWARDS THE OPPOSITE LEG, STARTING AT ONE END. CONTINUE THIS PROCEDURE UNTIL THE COVER IS SECURELY ATTACHED TO THE RETAINER.

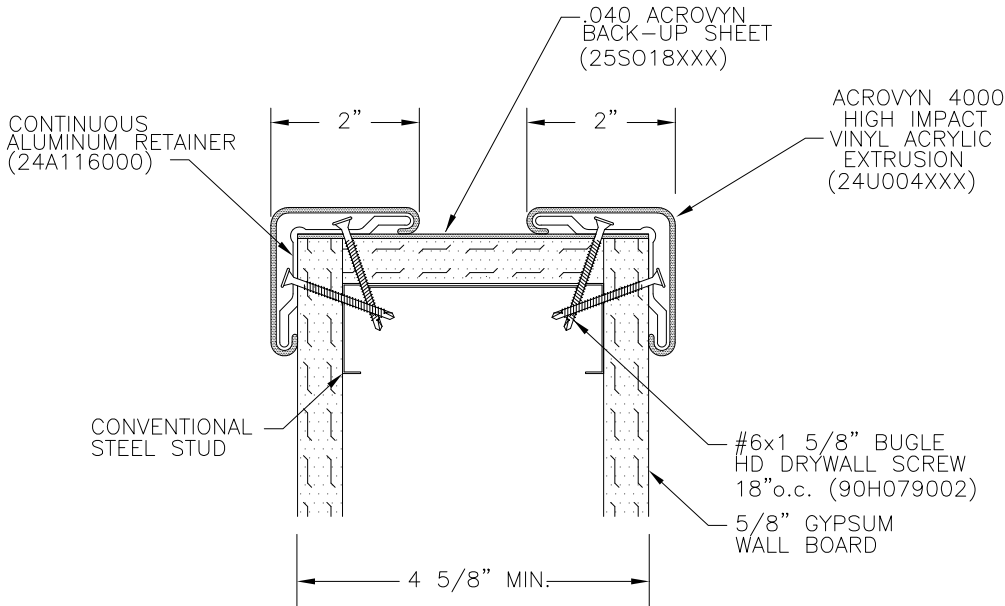

SSM-25AN

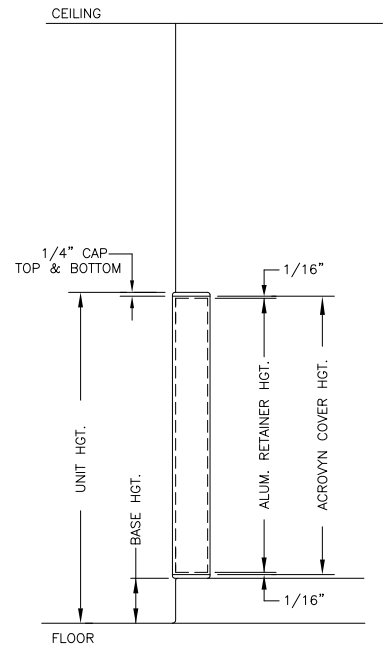

SURFACE MOUNTED GUARD
 AT PARTIAL HEIGHT ELEVATION

WALL CONDITION	SPECIFIED FASTENER	DRILL DIAMETERS		PART NUMBER
		WALL	RETAINER	
STEEL STUD/GYPSUM WALL WOOD STUD/GYPSUM WALL	#6 X 1-5/8" BUGLE HD. SMS	N/A	7/64"	90H079002
CONCRETE/CONC. BLOCK	{ AF-6 PLASTIC ANCHOR #10 X 1-1/2" PHILLIPS PAN HD. SMS }	15/64"	9/32"	90H039004 90H189002



Construction Specialties™
 6696 Route 405 Highway, Muncy PA 17756
 (800) 233-8493 • Fax (570) 546-4692 • www.c-sgroup.com

PROJECT:		REV.:
LOCATION:		F&F:
CUSTOMER:		SHEET
AGENT:		JOB NO.
DWG. BY:	DATE:	